

Kinetix 6200 and Kinetix 6500 Control Modules

Catalog Numbers

2094-SE02F-M00-S0, 2094-SE02F-M00-S1, 2094-EN02D-M01-S0, 2094-EN02D-M01-S1

Topic	Page
About the Control Modules	1
Catalog Number Explanation	2
Before You Begin	2
Install the Control Modules	4
Connector Data	6
Motor Overload Protection	11
Additional Resources	12

About the Control Modules

Each integrated axis (IAM) power module and axis (AM) power module requires one control module. Each control module provides user I/O, safety, auxiliary feedback, and motor feedback connections. Kinetix® 6200 control modules use sercos interface to communicate with the Logix5000™ controller and EtherNet/IP to access the safety configuration tool. Kinetix 6500 control modules use EtherNet/IP for programming the Logix5000 controller and safety configuration tool. In addition, the Kinetix 6200 and Kinetix 6500 control modules are available with either safe torque-off or safe speed monitoring functionality.

Refer to [Additional Resources](#) on [page 12](#) for user documentation supporting installation and wiring, integration with ControlLogix®, CompactLogix™, or SoftLogix™ controller platforms, troubleshooting, and safety functions.

Catalog Number Explanation

This publication applies to the Kinetix 6200 and Kinetix 6500 control modules.

Kinetix 6200 Sercos Control Modules

Cat. No.	Description
2094-SE02F-M00-S1	Kinetix 6200 control module, sercos fiber optic, safe speed monitoring
2094-SE02F-M00-S0	Kinetix 6200 control module, sercos fiber optic, safe torque-off

Kinetix 6500 EtherNet/IP Control Modules

Cat. No.	Description
2094-EN02D-M01-S1	Kinetix 6500 control module, EtherNet/IP, safe speed monitoring
2094-EN02D-M01-S0	Kinetix 6500 control module, EtherNet/IP, safe torque-off

Before You Begin

Remove all packing material, wedges, and braces from within and around the components. After unpacking, check the item nameplate catalog number against the purchase order.

Each 2094-SE02F-M00-S0 and 2094-EN02D-M01-S0 safe torque-off control module ships with one motion-allowed plug for the IOD connector. Install the 44-pin motion-allowed plug on the IOD connector when the safe torque-off functionality is not used and no other I/O connections are required for your application.

TIP Connector kits for user I/O, safety, and auxiliary feedback (catalog numbers 2090-K6CK-D44M or 2090-K6CK-D44S0) and motor feedback (catalog number 2090-K6CK-D15M), are not provided. Refer to the Kinetix Motion Accessories Technical Data, publication [GMC-TD004](#), for more information.

This procedure assumes you have prepared your panel, mounted your Bulletin 2094 power rail, and Bulletin 2094 power modules. For installation instructions regarding equipment and accessories not included here, refer to the instructions that came with those products.



ATTENTION: Plan the installation of your system so that you can perform all cutting, drilling, tapping, and welding with the system removed from the enclosure. Because the system is of the open type construction, be careful to keep any metal debris from falling into it. Metal debris or other foreign matter can become lodged in the circuitry and result in damage to components.

Module Compatibility

Kinetix 6000 IAM/AM modules and Bulletin 2094 power modules with Kinetix 6200 control modules are completely compatible and can be used together on the same Bulletin 2094 power rail.

IMPORTANT Kinetix 6200 (sercos) and Kinetix 6500 (EtherNet/IP) control modules are not compatible and cannot be used on the same Bulletin 2094 power rail.

Drive/Control Module Compatibility

IAM Module/ Control Module	IAM Power Module	2094-xMxx-S Kinetix 6000 AM Module	2094-BMxx-M AM Power Modules	
			Kinetix 6200 Control Module	Kinetix 6500 Control Module
2094-xCxx-Mxx-S Kinetix 6000 (sercos)	N/A	Fully compatible	Fully compatible	Not compatible
2094-SE02F-M00-Sx Kinetix 6200 (sercos)	2094-BCxx-Mxx-M			
2094-EN02D-M01-Sx Kinetix 6500 (EtherNet/IP)			Not compatible	Not compatible

Install the Control Modules

The IAM and AM power modules are equipped with two mounting hooks and a threaded hole. The Bulletin 2094 control modules have two mounting studs, guide pins, and a captive screw for mating the control module with a power module.

IMPORTANT For convenience and ease of use, mount the IAM and AM power modules on the power rail before mounting the control modules.

When the IAM power modules are placed on a flat surface, with the power-rail connectors facing down, the mounting screw that extends from the front of the drive and fastens to the power rail, pushes back and interferes with the control module installation.

Refer to the Kinetix 6200 and Kinetix 6500 IAM and AM Power Modules Installation Instructions, publication [2094-IN011](#), for more information.

Follow these steps to mount Bulletin 2094 control modules to IAM (inverter) power module or AM power modules. In this procedure an IAM power module is shown.

1. Remove all input power from the IAM power module.
Verify that the Power-applied indicator is off. When the indicator is on, voltage is present on the IAM and AM power module signal connectors.



ATTENTION: To avoid damage to equipment, do not mount your Bulletin 2094 control module to the power module when the Power-applied indicator is on. Remove all input power from the IAM power module before mounting the control module.

2. Position the control module in front of the power module.

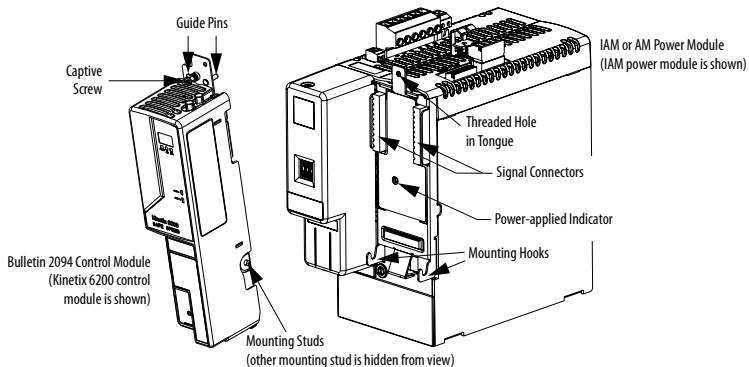

- Align the control module mounting studs so they engage with the power module hooks.

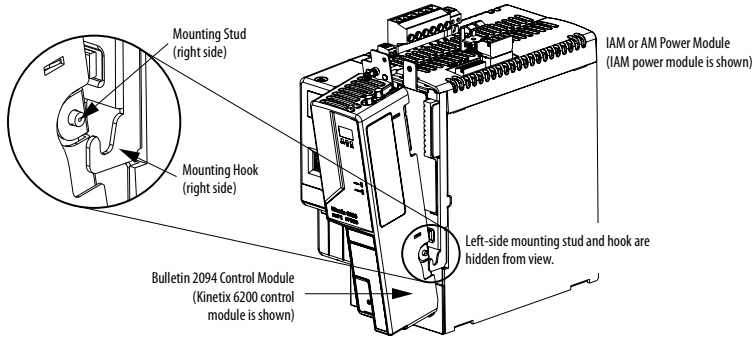

- Pivot the control module toward the power module to engage the signal connectors and guide pins.

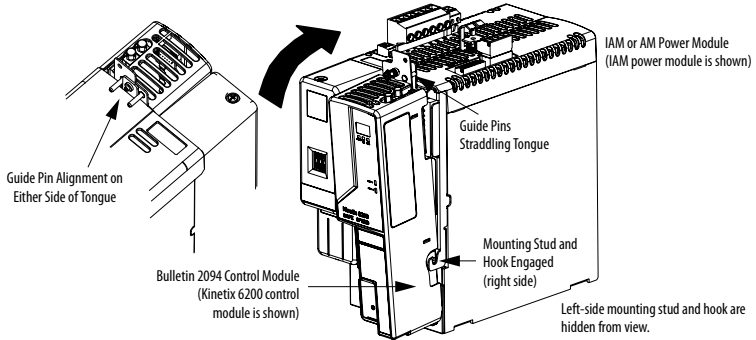

- Tighten the captive screw.

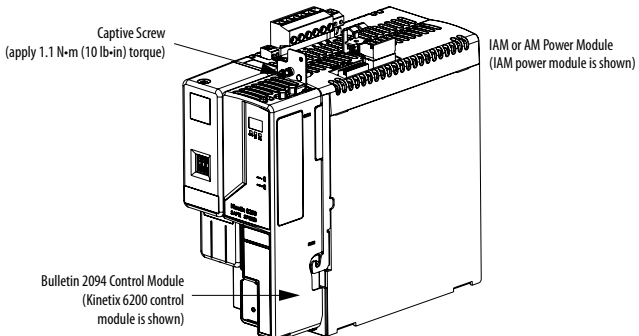

- Repeat [step 2](#) through [step 5](#) to mount a control module onto each power module installed on your Bulletin 2094 power rail.

Connector Data

Use these illustrations to identify the control module connectors and indicators.

Kinetix 6200 Control Module Features and Indicators (sercos)

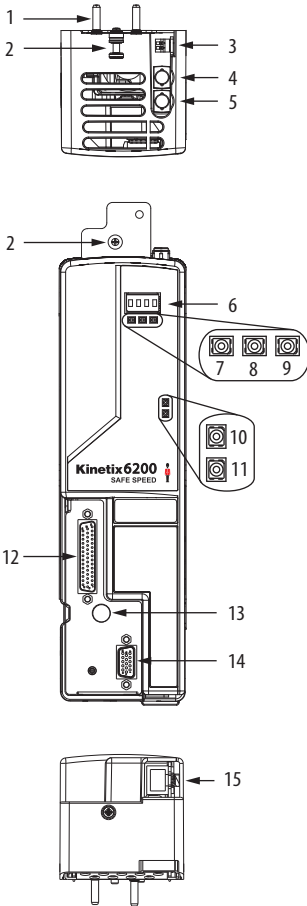

Control Module (2094-SE02F-M00-5x) Top View

Item	Description
1	Guide pins (2x)
2	Captive screw
3	Sercos communication rate and optical power switches
4	Sercos Transmit (Tx) connector
5	Sercos Receive (Rx) connector

Control Module (2094-SE02F-M00-5x) Front View

Item	Description
6	Four-character status display
7	PORT 1 status Indicator
8	Drive status indicator
9	Comm status indicator
10	DC bus status indicator
11	Safety lock status indicator (only 2094-SE02F-M00-S1 modules)
12	I/O, safety, and aux feedback (IOD) connector
13	Power module mounting screw access hole
14	Motor feedback (MF) connector

Control Module (2094-SE02F-M00-5x) Bottom View

Item	Description
15	Ethernet (PORT1) connector

Kinetix 6500 Control Module Connectors and Indicators (Ethernet)

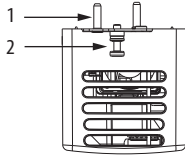

Control Module (2094-EN02D-M01-Sx) Top View

Item	Description
1	Guide pins (2x)
2	Captive screw

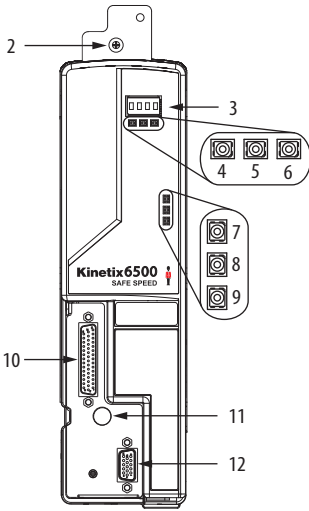

Control Module (2094-EN02D-M01-Sx) Front View

Item	Description
3	Four-character status display
4	PORT 1 status indicator
5	PORT 2 status indicator
6	Module status indicator
7	Network status indicator
8	DC bus status indicator
9	Safety lock status indicator (only 2094-EN02D-M01-S1 modules)
10	I/O, safety, and aux feedback (IOD) connector
11	Power module mounting screw access hole
12	Motor feedback (MF) connector

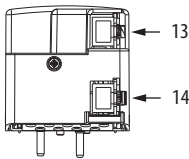

Control Module (2094-EN02D-M01-Sx) Bottom View

Item	Description
13	Ethernet (PORT1) connector
14	Ethernet (PORT2) connector

Kinetix 6200 and Kinetix 6500 Control Module Connectors

Designator	Description	Connector
IOD	User I/O (drive), safety, and auxiliary feedback	44-pin high-density D-shell
MF	Motor feedback	15-pin high-density D-shell
Tx and Rx	Sercos connections for controller programming (only Kinetix 6200 modules)	Sercos fiber-optic (2x)
PORT1	Ethernet connection for safety configuration	RJ45
PORT2	Ethernet connection for controller programming (only Kinetix 6500 modules)	



ATTENTION: To avoid damage to the sercos Rx and Tx connectors, use only finger-tight torque when attaching the fiber-optic cables to the Kinetix 6200 control modules. Do not use a wrench or any other mechanical assistance.

For more information, refer to Fiber-optic Cable Installation and Handling Instructions, publication [2090-IN010](#).

IOD Connector Pinouts

This is the IOD connector pinout for safe speed monitoring (-S1) control modules.

Catalog Numbers 2094-SE02F-M00-S1 and 2094-EN02D-M01-S1

IOD ⁽¹⁾ Pin	Signal	IOD Pin	Signal	IOD ⁽¹⁾ Pin	Signal	IOD ⁽¹⁾ Pin	Signal
0	–	12	–			33 (X32)	LM_IN_CHO
1	AUX_SIN+ AUX_A+	13	–	23 (S52)	SLS_IN_CHO	34 (X42)	LM_IN_CH1
2	AUX_SIN- AUX_A-	14	24VPWR ⁽²⁾	24 (S62)	SLS_IN_CH1	35 (51)	DC_OUT_CHO
3	AUX_COS+ AUX_B+	15	24VCOM ⁽²⁾	25	RESET_REF	36 (52)	DC_OUT_CH1
4	AUX_COS- AUX_B-	16	–	26 (S34)	RESET_IN	37 (S72)	ESM_IN_CHO
5	AUX_DATA+ AUX_I+	17 (A1)	SPWR	27 (S11)	TEST_OUT_0	38 (S82)	ESM_IN_CH1
6	AUX_DATA- AUX_I-	18 (A2)	SCOM	28 (S21)	TEST_OUT_1	39	24VPWR ⁽³⁾
7	AUX_CLK+	19 (S12)	SS_IN_CHO	29 (68)	SLS_OUT_CHO	40	24VCOM ⁽³⁾
8	AUX_CLK-	20 (S22)	SS_IN_CH1	30 (78)	SLS_OUT_CH1	41	INPUT1
9	EPWR_5V	21 (34)	SS_OUT_CHO	31 (S32)	DM_IN_CHO	42	INPUT2
10	ECOM					43	INPUT3
11	EPWR_9V	22 (44)	SS_OUT_CH1	32 (S42)	DM_IN_CH1	44	INPUT4

(1) Designators in parenthesis refer to the Guardmaster® MSR57P safety relay and PowerFlex® 750-Series safety option terminals.

(2) Signals 24VPWR and 24VCOM (IOD-14 and IOD-15) apply to only the 2094-SE02F-M00-S0 or 1094-EN02D-M01-S0 (safe torque-off) control modules.

(3) Signals 24VPWR and 24VCOM (IOD-39 and IOD-40) are a 24V DC source you can use to operate the digital inputs (50 mA maximum per input).

Refer to the Kinetix 6200 and Kinetix 6500 Safe Speed Monitoring Safety Reference Manual, publication [2094-RM001](#), for signal descriptions and more information on safe-speed monitoring safety functions.

This is the IOD connector pinout for the safe torque off (-S0) control modules.

2094-SE02F-M00-S0 and 2094-EN02D-M01-S0 Control Modules

IOD Pin	Signal	IOD Pin	Signal	IOD Pin	Signal	IOD Pin	Signal
0	–	12	–			33	–
1	AUX_SIN+ AUX_A+	13	–	23	SS_IN_CH2	34	–
2	AUX_SIN- AUX_A-	14	24VPWR	24	SS_IN_CH3	35	–
3	AUX_COS+ AUX_B+	15	24VCOM	25	RESET_REF	36	–
4	AUX_COS- AUX_B-	16	–	26	RESET_IN	37	–
5	AUX_DATA+ AUX_I+	17	SPWR	27	TEST_OUT_0	38	–
6	AUX_DATA- AUX_I-	18	SCOM	28	TEST_OUT_1	39	24VPWR ⁽¹⁾
7	AUX_CLK+	19	SS_IN_CH0	29	–	40	24VCOM ⁽¹⁾
8	AUX_CLK-	20	SS_IN_CH1	30	–	41	INPUT1
9	EPWR_5V	21	SS_OUT_CH0	31	–	42	INPUT2
10	ECOM				–	43	INPUT3
11	EPWR_9V	22	SS_OUT_CH1	32	–	44	INPUT4

(1) Signals 24VPWR and 24VCOM (IOD-39 and IOD-40) are a 24V DC source you can use to operate the digital inputs (50 mA maximum per input).

Refer to the Kinetix 6200 and Kinetix 6500 Safe Torque-off Safety Reference Manual, publication [2094-RM002](#), for signal descriptions and more information on safe torque-off safety functions.

IOD Connector Pin Orientation

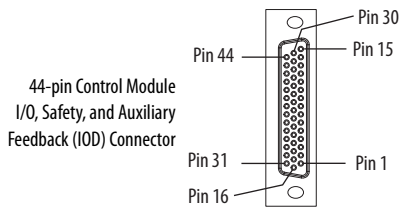

Feedback Connector Pinouts

MF Pin	Description	Signal
1	Sine differential input + A differential input +	MTR_SIN+ MTR_A+
2	Sine differential input - A differential input -	MTR_SIN- MTR_A-
3	Cosine differential input + B differential input +	MTR_COS+ MTR_B+
4	Cosine differential input - B differential input -	MTR_COS- MTR_B-
5	Data differential input/output + Index differential input +	MTR_DATA+ MTR_I+
6	Encoder common	MTR_ECOM
7	Encoder 9V power output	MTR_EPWR9V
8	Hall commutation S3 input	MTR_S3
9	Clock output +	MTR_CLK+
10	Data differential input/output - Index differential input -	MTR_DATA- MTR_I-
11	Motor thermostat (normally closed) ⁽¹⁾	MTR_TS+
12	Hall commutation S1 input	MTR_S1
13	Hall commutation S2 input	MTR_S2
14	Encoder 5V power output	MTR_EPWR5V
15	Clock output -	MTR_CLK-

(1) Not applicable unless motor has integrated thermal protection.

IMPORTANT

Drive-to-motor power cables must not exceed 90 m (295.5 ft). Additional limitations apply. Refer to the Kinetix 6200 and Kinetix 6500 Modular Servo Drive User Manual, publication [2094-UM002](#), for more information.

MF Connector Pin Orientation

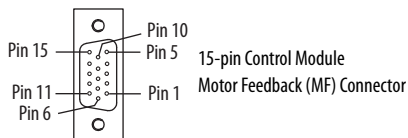

Motor Overload Protection

This servo drive uses solid-state motor overload protection that operates in accordance with UL 508C. Motor overload protection is provided by algorithms (thermal memory) that predict actual motor temperature based on operating conditions as long as control power is continuously applied. However, when control power is removed, thermal memory is not retained.

In addition to thermal memory protection, this drive provides an input for an external temperature sensor/thermistor device, embedded in the motor, to support the UL requirement for motor overload protection.

Some motors supported by this drive do not contain temperature sensors/thermistors; therefore, motor overload protection against excessive consecutive motor overloads with power cycling is not supported.

This servo drive meets the following UL 508C requirements for solid-state overload protection.

Motor Overload Protection Trip Point	Value
Ultimately	100% overload
Within 8 minutes	200% overload
Within 20 seconds	600% overload



ATTENTION: To avoid damage to your motor due to overheating caused by excessive, successive motor overload trips, follow the wiring diagram provided in the user manual for your motor and drive combination.

Refer to your servo drive user manual for the interconnect diagram that illustrates the wiring between your motor and drive.

Additional Resources

These documents contain additional information concerning related products from Rockwell Automation.

Resource	Description
Kinetix 6200 and Kinetix 6500 Modular Multi-axis Servo Drive User Manual, publication 2094-UM002	Provides information on installing, configuring, startup, troubleshooting, and applications for your Kinetix 6200 and Kinetix 6500 servo drive systems.
Kinetix 6000M Integrated Drive-Motor System User Manual, publication 2094-UM003	Provides information on installing, configuring, startup, troubleshooting, and applications for your Kinetix 6000M integrated drive-motor (IDM) system.
Kinetix 6000 Power Rail Installation Instructions, publication 2094-IN003	Provides information on the installation of your Bulletin 2094 Power Rail.
Fiber-optic Cable Installation and Handling Instructions, publication 2090-IN010	Provides information on proper handling, installing, testing, and troubleshooting fiber-optic cables.
System Design for Control of Electrical Noise Reference Manual, publication GMC-RM001	Provides information, examples, and techniques designed to minimize system failures caused by electrical noise.
EMC Noise Management DVD, publication GMC-SP001	
Kinetix 6200 and Kinetix 6500 Safe Speed Monitoring Safety Reference Manual, publication 2094-RM001	Provides information on wiring, configuring, and troubleshooting the safety functions of your Kinetix 6200 and Kinetix 6500 drives.
Kinetix 6200 and Kinetix 6500 Safe Torque-off Safety Reference Manual, publication 2094-RM002	
Kinetix Motion Control Selection Guide, publication GMC-SG001	Specifications, motor/servo-drive system combinations, and accessories for Kinetix motion control products.
Kinetix Servo Drives Specifications, publication GMC-TD003	Provides product specifications for Kinetix Integrated Motion over EtherNet/IP, Integrated Motion over sercos interface, EtherNet/IP networking, and component servo drive families.
Rockwell Automation Product Certification, website http://rockwellautomation.com/products/certification	For declarations of conformity (DoC) currently available from Rockwell Automation.
Rockwell Automation Industrial Automation Glossary, publication AG-7.1	A glossary of industrial automation terms and abbreviations.

You can view or download publications at <http://literature.rockwellautomation.com>. To order paper copies of technical documentation, contact your local Allen-Bradley distributor or Rockwell Automation sales representative.

Allen-Bradley, CompactLogix, ControlLogix, Guardmaster, Kinetix, Logix5000, PowerFlex, Rockwell Software, Rockwell Automation, and SoftLogix are trademarks of Rockwell Automation, Inc.

Trademarks not belonging to Rockwell Automation are property of their respective companies.

Rockwell Otomasyon Ticaret A.Ş., Kar Plaza İş Merkezi E Blok Kat:6 34752 İçerenköy, İstanbul, Tel: +90 (216) 5698400

www.rockwellautomation.com

Power, Control and Information Solutions Headquarters

Americas: Rockwell Automation, 1201 South Second Street, Milwaukee, WI 53204-2496 USA, Tel: (1) 414.382.2000, Fax: (1) 414.382.4444
Europe/Middle East/Africa: Rockwell Automation NV, Pegasus Park, De Kleetlaan 12a, 1831 Diegem, Belgium, Tel: (32) 2 663 0600, Fax: (32) 2 663 0640
Asia Pacific: Rockwell Automation, Level 14, Core F, Cyberport 3, 100 Cyberport Road, Hong Kong, Tel: (852) 2887 4788, Fax: (852) 2508 1846

Publication 2094-IN012C-EN-P - August 2013

Supersedes Publication 2094-IN012B-EN-P - October 2009

PN-215234

Copyright © 2013 Rockwell Automation, Inc. All rights reserved. Printed in the U.S.A.