

YASKAWA

Sigma-7Siec Hardware Manual



100V/200V Safety Standards and Performance Level

Certification marks for the standards for which the product has been certified by certification bodies are shown on nameplate. Products that do not have the marks are not certified for the standards.

North American Safety Standards (UL)



Product	Model	UL Standards (UL File No.)
SERVOPACKs	• SGD7S	UL 61800-5-1 (E147823), CSA C22.2 No.274

European Directives



Product	Model	European Directive	Harmonized Standards
SERVO- PACKs	• SGD7S	Machinery Directive 2006/42/EC	EN ISO13849-1: 2015
		EMC Directive 2014/30/EU	EN 55011 group 1, class A EN 61000-6-2 EN 61000-6-4 EN 61800-3 (Category C, Second environ- ment)
		Low Voltage Directive 2014/35/EU	EN 50178 EN 61800-5-1

Safety Standards



Product	Model	European Directive	Harmonized Standards
SERVO- PACKs	• SGD7S	Safety of Machinery	EN ISO13849-1:2015 IEC 60204-1
		Functional Safety	IEC 61508 series IEC 62061 IEC61800-5-2
		EMC	IEC 61326-3-1

Safety Performance Amplifier Alone

Items	Standards	Performance Level	
Safety Integrity Level	IEC 61508	SIL3	
	IEC 62061	SILCL3	
Mission Time	IEC 61508	10 years	20 years
Probability of Dangerous Failure per Hour	IEC 61508 IEC 62061	PFH = 4.60×10^{-9} [1/h] 4.60% of SIL3	PFH = 4.62×10^{-9} [1/h] 4.62% of SIL3
Performance Level	EN ISO 13849-1	PLe (Category 3)	
Mean Time to Dangerous Failure of Each Channel	EN ISO 13849-1	MTTFd: High	
Average Diagnostic Coverage	EN ISO 13849-1	DCavg: Medium	
Stop Category	IEC 60204-1	Stop category 0	
Safety Function	IEC 61800-5-2	STO	
Hardware Fault Tolerance	IEC 61508	HFT = 1	
Subsystem	IEC 61508	B	

Safety Performance with Safety Module

Items	Standards	Performance Level	
Safety Integrity Level	IEC 61508	SIL2	
	IEC 62061	SILCL2	
Probability of Dangerous Failure per Hour	IEC 61508 IEC 62061	PFH = 3.3×10^{-7} [1/h] 3.3% of SIL2	
Performance Level	EN ISO 13849-1	PL d (Category 2)	
Mean Time to Dangerous Failure of Each Channel	EN ISO 13849-1	MTTFd: High	
Average Diagnostic Coverage	EN ISO 13849-1	DCavg: Medium	
Safety Function	IEC 61800-5-2	STO/SS1/SS2/SLS	
Mission Time	IEC 61508	10 Years	
Hardware Fault Tolerance	IEC 61508	HFT = 1	
Subsystem	IEC 61508	B	

400V Safety Standards and Performance Level

Certification marks for the standards for which the product has been certified by certification bodies are shown on nameplate. Products that do not have the marks are not certified for the standards.

North American Safety Standards (UL)



Product	Model	UL Standards (UL File No.)
SERVOPACKs	• SGD7S	UL 61800-5-1 (E147823), CSA C22.2 No.274

European Directives



Product	Model	European Directive	Harmonized Standards
SERVO- PACKs	• SGD7S	Machinery Directive 2006/42/EC	EN ISO13849-1: 2015
		EMC Directive 2014/30/EU	EN 55011 group 1, class A EN 61000-6-2 EN 61000-6-4 EN 61800-3 (Category C, Second environment)
		Low Voltage Directive 2014/35/EU	EN 50178 EN 61800-5-1
		RoHS Directive 2011/65/EU	EN 50581

Safety Standards



Product	Model	European Directive	Harmonized Standards
SERVO- PACKs	• SGD7S	Safety of Machinery	EN ISO13849-1:2015 IEC 60204-1
		Functional Safety	IEC 61508 series IEC 62061 IEC61800-5-2
		EMC	IEC 61326-3-1

Safety Performance Amplifier Alone

Items	Standards	Performance Level	
Safety Integrity Level	IEC 61508	SIL3	
	IEC 62061	SILCL3	
Mission Time	IEC 61508	10 years	20 years
Probability of Dangerous Failure per Hour	IEC 61508 IEC 62061	PFH = 4.60×10^{-9} [1/h] 4.60% of SIL3	PFH = 4.62×10^{-9} [1/h] 4.62% of SIL3
Performance Level	EN ISO 13849-1	PLe (Category 3)	
Mean Time to Dangerous Failure of Each Channel	EN ISO 13849-1	MTTFd: High	
Average Diagnostic Coverage	EN ISO 13849-1	DCavg: Medium	
Stop Category	IEC 60204-1	Stop category 0	
Safety Function	IEC 61800-5-2	STO	
Hardware Fault Tolerance	IEC 61508	HFT = 1	
Subsystem	IEC 61508	B	

Safety Performance with Safety Module

Items	Standards	Performance Level	
Safety Integrity Level	IEC 61508	SIL2	
	IEC 62061	SILCL2	
Probability of Dangerous Failure per Hour	IEC 61508 IEC 62061	PFH = 3.3×10^{-7} [1/h] 3.3% of SIL2	
Performance Level	EN ISO 13849-1	PL d (Category 2)	
Mean Time to Dangerous Failure of Each Channel	EN ISO 13849-1	MTTFd: High	
Average Diagnostic Coverage	EN ISO 13849-1	DCavg: Medium	
Safety Function	IEC 61800-5-2	STO/SS1/SS2/SLS	
Mission Time	IEC 61508	10 Years	
Hardware Fault Tolerance	IEC 61508	HFT = 1	
Subsystem	IEC 61508	B	

Table of Contents

1 Introduction

1.1 Sigma-7Siec Features	-3
1.2 Sigma-7Siec Appearance	-4
1.3 Model Number Designation	-6
1.4 Accessories	-6

2 Specifications and Settings

2.1 Specifications	-7
2.2 DIP Switch Settings	-13
2.3 Rotary Switches	-14
2.4 Switch Factory Settings	-14

3 Installation Standards

3.1 Mechanical Installation/Dimensions	-15
3.2 Installing Multiple SERVOPACKS in a Control Panel	-16

4 Inputs and Outputs

4.1 Input Signals	-19
4.2 Output Signals	-21
4.3 I/O Signal Connector (CN1) Pin Arrangement	-23
4.4 I/O Signal Wiring Examples	-25
4.5 I/O Circuits	-29

5 LED Outputs 31

6 Ethernet Connectivity

6.1 Ethernet Connector Details	-33
6.2 Ethernet Cable	-34
6.3 Ethernet Connection Examples	-34

7 Cable Diagrams

7.1 SBK-U-VBA-xx (200V Only) -----	37
7.2 JZSP-CSI02-x-E (200V Only) -----	38

8 EMC Installation Conditions ----- 39

9 Safety ----- 43

9.1 Safety Modules -----	43
9.2 Safety Module Installation -----	43
9.3 Supported Safety Functions -----	43
9.4 Relationship with Function Blocks for Motion -----	43
9.5 Risk Assessment -----	44

1 Introduction

1.1 Sigma-7Siec Features

The Sigma-7Siec is a single-axis machine controller that is enclosed inside a Sigma-7 servo amplifier, providing a compact, all-in-one servo/controller package with the following features:

- PLCopen for Motion Control, including indexing, virtual camming, and servo parameter maintenance capability. Multiple communications protocols are supported, including: Modbus/TCP, EtherNet/IP, OPC and user customizable socket communications.
- Sigma-7 self-tuning, anti-vibration, and other high performance, easy-to-implement servo control features.

1.2 Sigma-7Siec Appearance

The following figures show the external appearance of the Sigma-7Siec controller.

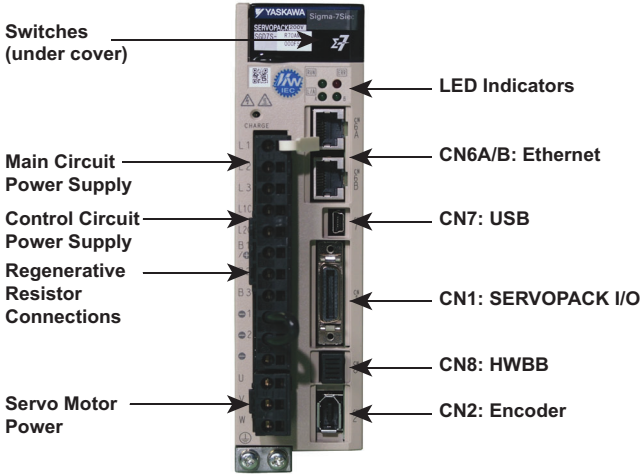

200V Front View

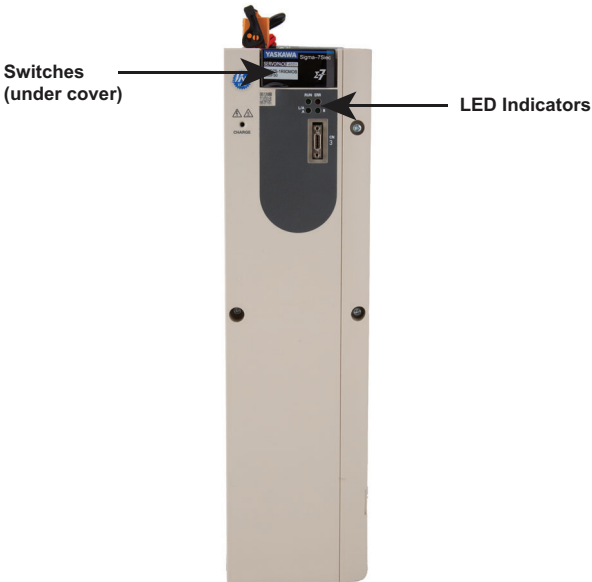

400V Front View

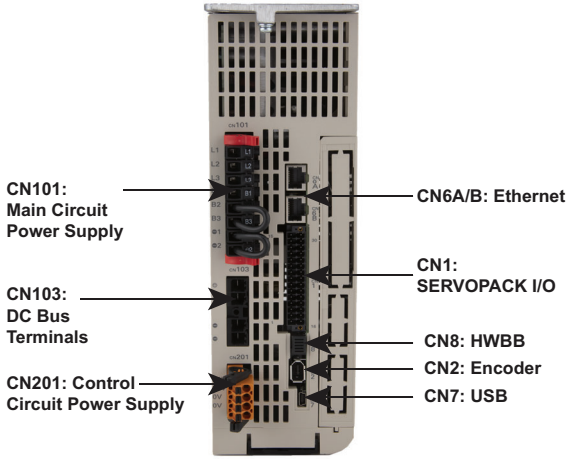

400V Top View

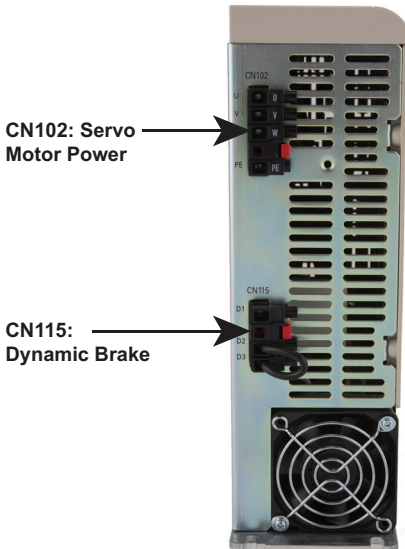

400V Bottom View

1.3 Model Number Designation



1st+2nd+3rd digits Maximum Applicable Motor Capacity

Voltage	Code	Specification	Voltage	Code	Specification
Three-phase, 200 VAC	R70 ¹	0.05 kW	Three-phase, 400 VAC	1F9	500 W
	R90 ²	0.1 kW		3P5	1.0 kW
	1R8 ²	0.2 kW		5P4	1.5 kW
	2R8 ²	0.4 kW		8P4	2.0 kW
	3R8	0.5 kW		120	3.0 kW
	5R5 ²	0.75 kW		170	5.0 kW
	7R6	1.0 kW		210 ^{1,4}	6.0 kW
	120	1.5 kW		260 ^{1,4}	7.5 kW
	180	2.0 kW		280 ^{1,4}	11 kW
	200	3.0 kW		370 ^{1,4}	15 kW
	330	5.0 kW			
	470	6.0 kW			
	550	7.5 kW			
	590	11 kW			
780	15 kW				
Single-phase, 100 VAC	R70	0.05 kW			
	R90	0.1 kW			
	2R1	0.2 kW			
	2R8	0.4 kW			

4th digit Voltage

Code	Specification
F	100 VAC
A	200 VAC
D	400 VAC

8th+9th+10th digits Hardware Options Specification

Code	Specification	Applicable Models
000	Without options	All models

5th+6th digits Interface

Code	Specification
M0	Sigma-7Siec (built-in single-axis control)

11th+12th+13th digits FT/EX Specification

Code	Specification
F50	Application function for Sigma-7Siec
F82	Application function for Sigma-7Siec with support for SGM7D motors

7th digit Design Revision Order

- A: Global design revision
- B: 400V Global design revision

14th+15th+16th digits Option Module

Code	Specification
Blank	Standard
010 ¹	Safety Module ³⁾

1.4 Accessories

System Components			
Type	Description	Model Number	Note
Accessories and Cables (100 VAC and 200 VAC)	CN1 Terminal Block Conversion Kit	SBK-U-MP2Bxx	xx denotes cable length * A5: 0.5 m * 01: 1.0 m * 03: 3.0 m
	CN1 Cable (Flying leads)	JZSP-CSI02-x-E	x denotes cable length * A: 1.0 m * B: 2.0 m * C: 3.0 m
Communication	Ethernet Cable	Customer Supplied	Use high quality shielded industrial Ethernet cables (Yaskawa model JZSP-CM3RRM0-xx-E is recommended)
Option Case Kit	Module cover and mounting plate for 200V amps	SGDV-OZA01A	Used for mounting safety module
Option Case Kit	Mounting plate for 400V amps	JZSP-P7R2-8-E	Using for mounting safety module

2 Specifications and Settings

2.1 Specifications

2.1.1 200 VAC Specifications

Item		Specification	
Control Method		IGBT-based PWM control, sine wave current drive	
Feedback	With Rotary Servomotor	Serial encoder: 20 bits or 24 bits (incremental encoder/ absolute encoder) 22 bits (absolute encoder)	
	With Linear Servomotor	<ul style="list-style-type: none"> Absolute linear encoder (The signal resolution depends on the absolute linear encoder.) Incremental linear encoder (The signal resolution depends on the incremental linear encoder or Serial Converter Unit.) 	
Environmental Conditions	Surrounding Air Temperature	-5°C to 55°C (With derating, usage is possible between 55°C and 60°C.)	
	Storage Temperature	-20°C to 85°C	
	Surrounding Air Humidity	95% relative humidity max. (with no freezing or condensation)	
	Storage Humidity	95% relative humidity max. (with no freezing or condensation)	
	Vibration Resistance	4.9 m/s ²	
	Shock Resistance	19.6 m/s ²	
	Degree of Protection	Degree	SERVOPACK Model: SGD7S-
		IP20	R70A, R90A, 1R6A, 2R8A, 3R8A, 5R5A, 7R6A, 120A, R70F, R90F, 2R1F, 2R8F
		IP10	180A, 200A, 330A, 470A, 550A, 590A, 780A
	Pollution Degree	<ul style="list-style-type: none"> Must be no corrosive or flammable gases. Must be no exposure to water, oil, or chemicals. Must be no dust, salts, or iron dust. 	
Altitude	1,000 m or less. (With derating, usage is possible between 1,000 m and 2,000 m.)		
Others	Do not use the SERVOPACK in the following locations: Locations subject to static electricity noise, strong electromagnetic/magnetic fields, or radioactivity		
Applicable Standards		Compliance with UL Standards, EU Directives and Other Safety Standards	
Mounting	Mounting	SERVOPACK Model: SGD7S-	
	Base-mounted	All Models	
	Rack-mounted	R70A, R90A, 1R6A, 2R8A, 3R8A, 5R5A, 7R6A, 120A, 180A, 200A, 330A, R70F, R90F, 2R1F, 2R8F	
	Duct-ventilated	470A, 550A, 590A, 780A	

2 Specifications and Settings

2.1.1 200 VAC Specifications

(cont'd)

Item		Specification
Performance	Speed Control Range	1:5000 (At the rated torque, the lower limit of the speed control range must not cause the Servomotor to stop.)
	Coefficient of Speed Fluctuation	±0.01% of rated speed max. (for a load fluctuation of 0% to 100%)
		0% of rated speed max. (for a voltage fluctuation of ±10%)
		±0.1% of rated speed max. (for a temperature fluctuation of 25°C ±25°C)
Torque Control Precision (Repeatability)	±1%	
Soft Start Time Setting	0 s to 10 s (Can be set separately for acceleration and deceleration.)	
I/O Signals	Encoder Divided Pulse Output	Phase A, phase B, phase C: Line-driver output Number of divided output pulses: Any setting is allowed.
	Linear Servomotor Overheat Protection Signal Input	Number of input points: 1 Input voltage range: 0 V to +5 V
	Digital Input Signals That Can Be Allocated	Allowable voltage range: 24 VDC ±20% Number of input points: 7
		Input method: Sink inputs or source inputs Input Signals <ul style="list-style-type: none"> • P-OT (Forward Drive Prohibit) and N-OT (Reverse Drive Prohibit) signals • /EXT1 External latch signal input (General purpose input) • /EXT2 External latch signal input (General purpose input) • /EXT3 External latch signal input (General purpose input) • /P-CL (Forward External Torque Limit) and /N-CL (Reverse External Torque Limit) signals • FSTP (Forced Stop Input) signal A signal can be allocated and the positive and negative logic can be changed.
I/O Signals	Fixed Output	Allowable voltage range: 5 VDC to 30 VDC Number of output points: 1 Output signal: ALM (Servo Alarm) signal
		Allowable voltage range: 5 VDC to 30 VDC Number of output points: 3 (A photocoupler output (isolated) is used.)
	Digital Output Signals That Can Be Allocated	Output Signals <ul style="list-style-type: none"> • /COIN (Positioning Completion) signal • /V-CMP (Speed Coincidence Detection) signal • /TGON (Rotation Detection) signal • /S-RDY (Servo Ready) signal • /CLT (Torque Limit Detection) signal • /VLT (Speed Limit Detection) signal • /BK (Brake) signal • /WARN (Warning) signal • /NEAR (Near) signal A signal can be allocated and the positive and negative logic can be changed.

(cont'd)

Item		Specification	
Communications	RS-422A Communications (CN502)	Interfaces	A JUSP-JC001 Communications Unit is required to connect to a Digital Operator (JUSP-OP05A-1-E).
		1:N Communications	Up to N = 15 stations possible for RS-422A port
		Axis Address Setting	Set with parameters.
	USB Communications (CN7)	Interface	Personal computer (with SigmaWin+)
Communications Standard		Conforms to USB2.0 standard (12 Mbps).	
Displays/Indicators		CHARGE, PWR, CN, RUN, ERR, and L/A (A and B) indicators, and one-digit seven-segment display	
Ethernet IP Address Setting Switches		Used to configure IP address	
Analog Monitor (CN5)		Number of points: 2 Output voltage range: ± 10 VDC (effective linearity range: ± 8 V) Resolution: 16 bits Accuracy: ± 20 mV (Typ) Maximum output current: ± 10 mA Settling time ($\pm 1\%$): 1.2 ms (Typ)	
Dynamic Brake (DB)		Activated when a servo alarm or overtravel (OT) occurs, or when the power supply to the main circuit or servo is OFF.	
Regenerative Processing		Built-in (An external resistor must be connected to the SGD7S-470A to -780A.) Refer to the following manual for details.  S-7-Series AC Servo Drive Peripheral Device Selection Manual (Manual No.: SIEP S800001 32)	
Overtravel (OT) Prevention		Stopping with dynamic brake, deceleration to a stop, or coasting to a stop for the P-OT (Forward Drive Prohibit) or N-OT (Reverse Drive Prohibit) signal	
Protective Functions		Overcurrent, overvoltage, low voltage, overload, regeneration error, etc.	
Utility Functions		Gain adjustment, alarm history, jogging, origin search, etc.	
Safety Functions	Inputs	/HWBB1 and /HWBB2: Base block signals for Power Modules	
	Output	EDM1: Monitors the status of built-in safety circuit (fixed output).	
	Applicable Standards	ISO13849-1 PLe (Category 3), IEC61508 SIL3	
Applicable Option Modules		Safety Module	

2.1.2 400 VAC Specifications

Item		Specification
Control Method		IGBT-based PWM control, sine wave current drive
Feedback	With Rotary Servomotor	Serial encoder: 24 bits (incremental encoder/absolute encoder)
	With Linear Servomotor	<ul style="list-style-type: none"> Absolute linear encoder (The signal resolution depends on the absolute linear encoder.) Incremental linear encoder (The signal resolution depends on the incremental linear encoder or Serial Converter Unit.)
Environmental Conditions	Surrounding Air Temperature*1	-5°C to 55°C
	Storage Temperature	-20°C to 85°C
	Surrounding Air Humidity	95% relative humidity max. (with no freezing or condensation)
	Storage Humidity	95% relative humidity max. (with no freezing or condensation)
	Vibration Resistance	4.9 m/s ²
	Shock Resistance	19.6 m/s ²
	Degree of Protection	IP10
	Pollution Degree	2 <ul style="list-style-type: none"> Must be no corrosive or flammable gases. Must be no exposure to water, oil, or chemicals. Must be no dust, salts, or iron dust.
	Altitude	1,000 m or less.
	Others	Do not use the SERVOPACK in the following locations: Locations subject to static electricity noise, strong electromagnetic/magnetic fields, or radioactivity
Applicable Standards		Refer to the following section for details.  Compliance with UL Standards, EU Directives, and Other Safety Standards on page xxi
Mounting		Base-mounted
Performance	Speed Control Range	1:5000 (At the rated torque, the lower limit of the speed control range must not cause the Servomotor to stop.)
	Coefficient of Speed Fluctuation*2	±0.01% of rated speed max. (for a load fluctuation of 0% to 100%)
		0% of rated speed max. (for a voltage fluctuation of ±10%)
		±0.1% of rated speed max. (for a temperature fluctuation of 25°C ±25°C)
	Torque Control Precision (Repeatability)	±1%
Soft Start Time Setting	0 s to 10 s (Can be set separately for acceleration and deceleration.)	

Item		Specification	
I/O Signals	Encoder Divided Pulse Output	Phase A, phase B, phase C: Line-driver output Number of divided output pulses: Any setting is allowed.	
	Linear Servomotor Overheat Protection Signal Input	Number of input points: 1 Input voltage range: 0 V to +5 V	
	Sequence Input Signals	Input Signals That Can Be Allocated	Allowable voltage range: 24 VDC \pm 20% Number of input points: 7
			Input method: Sink inputs or source inputs Input Signals <ul style="list-style-type: none"> • P-OT (Forward Drive Prohibit) and N-OT (Reverse Drive Prohibit) signals • /Probe1 (Probe 1 Latch Input) signal • /Probe2 (Probe 2 Latch Input) signal • /Home (Home Switch Input) signal • /P-CL (Forward External Torque Limit) and /N-CL (Reverse External Torque Limit) signals • /SI0 and /SI3 (General-Purpose Input) signals A signal can be allocated and the positive and negative logic can be changed.
	Sequence Output Signals	Fixed Output	Allowable voltage range: 5 VDC to 30 VDC Number of output points: 1 Output signal: ALM (Servo Alarm) signal
		Output Signals That Can Be Allocated	Allowable voltage range: 5 VDC to 30 VDC Number of output points: 5 (A photocoupler output (isolated) is used.)
			Output Signals <ul style="list-style-type: none"> • /COIN (Positioning Completion) signal • /V-CMP (Speed Coincidence Detection) signal • /TGON (Rotation Detection) signal • /S-RDY (Servo Ready) signal • /CLT (Torque Limit Detection) signal • /VLT (Speed Limit Detection) signal • /BK (Brake) signal • /WARN (Warning) signal • /NEAR (Near) signal • /ZONE0 (ZONE Signal 1 Output) signal • /ZONE1 (ZONE Signal 2 Output) signal • /ZONE2 (ZONE Signal 3 Output) signal • /ZONE3 (ZONE Signal 4 Output) signal • /nZONE (nZONE Output) signal A signal can be allocated and the positive and negative logic can be changed.
Communications	RS-422A Communications (CN502)	Interfaces	Digital Operator (JUSP-OP05A-1-E).
		1:N Communications	Up to N = 15 stations possible for RS-422A port
		Axis Address Setting	Set with parameters.
	USB Communications (CN7)	Interface	Personal computer (with SigmaWin+) The software version of the SigmaWin+ must be version 7.11 or higher.
Communications Standard		Conforms to USB2.0 standard (12 Mbps).	

2 Specifications and Settings

2.1.2 400 VAC Specifications

Item	Specification	
Displays/Indicators	CHARGE, PWR, RUN, ERR, and L/A (A and B) indicators, and one-digit seven-segment display	
Ethernet IP Address Setting Switches	Used to configure IP address	
Analog Monitor (CN5)	Number of points: 2 Output voltage range: ± 10 VDC (effective linearity range: ± 8 V) Resolution: 16 bits Accuracy: ± 20 mV (Typ) Maximum output current: ± 10 mA Settling time ($\pm 1\%$): 1.2 ms (Typ)	
Dynamic Brake (DB)	Activated when a servo alarm or overtravel (OT) occurs, or when the power supply to the main circuit or servo is OFF.	
Regenerative Processing	Built-in Refer to the catalog for details.	
Overtravel (OT) Prevention	Stopping with dynamic brake, deceleration to a stop, or coasting to a stop for the P-OT (Forward Drive Prohibit) or N-OT (Reverse Drive Prohibit) signal	
Protective Functions	Overcurrent, overvoltage, low voltage, overload, regeneration error, etc.	
Utility Functions	Gain adjustment, alarm history, jogging, origin search, etc.	
Safety Functions	Inputs	/HWBB1 and /HWBB2: Base block signals for Power Modules
	Output	EDM1: Monitors the status of built-in safety circuit (fixed output).
	Applicable Standards *3	ISO13849-1 PLe (category 3), IEC61508 SIL3

* 1. If you combine a Σ -7-Series SERVOPACK with a Σ -V-Series Option Module, the surrounding air temperature specification of the Σ -V-Series SERVOPACKs must be used, i.e., 0°C to 55°C. Also, the applicable surrounding range cannot be increased by derating.

* 2. The coefficient of speed fluctuation for load fluctuation is defined as follows:

$$\text{Coefficient of speed fluctuation} = \frac{\text{No-load motor speed} - \text{Total-load motor speed}}{\text{Rated motor speed}} \times 100\%$$

* 3. Always perform risk assessment for the system and confirm that the safety requirements are met.

2.2 DIP Switch Settings

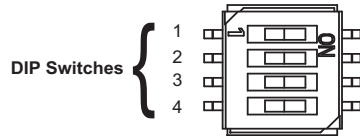
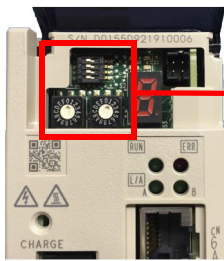

Rotary Switches
(used to set IP address)

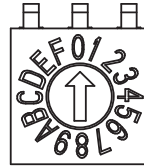

Rotary Switch 1

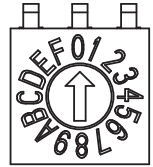

Rotary Switch 0

Switch	Name	Setting	Operating Mode	Setting for Normal Operation	Details
1	STOP	ON	User program execution inhibited	OFF	Inhibits user program execution
		OFF	Normal operation		
2	SUP	ON	Firmware programming mode	OFF	Enables servo controller firmware programming. This mode can also be enabled via web UI without changing the DIP switch.
		OFF	Normal operation		
3	INIT	ON	Configuration bypass mode	OFF	Set to ON to bypass the stored configuration (e.g. in case of a configuration problem that prevents servo controller startup)
		OFF	Normal operation		
4	E-INIT	ON	Rotary switches ignored	OFF	IP address is set from configuration settings in servo controller
		OFF	Normal operation		Rotary switches used to set IP address

2.3 Rotary Switches

When DIP switch 4 (E-INIT) is ON, the rotary switches are ignored. The IP address is set from configuration settings stored on the servo controller.

Rotary switches are normally used to set the IP address. This is the case when DIP switch 4 (E-INIT) is OFF

- If both rotary switches are set to 0, use DHCP.
- If either rotary switch is non zero, the last octet of the IP address is set by the value on the switches. Note that the switch values are labeled in hexadecimal. The IP address will be 192.168.1.x where x is 0x01 to 0xFF for a decimal value of 01 to 255.

Rotary Switch 1	Rotary Switch 0	IP Address
0	0	Set by DHCP
0	1	192.168.1.1
0	2	192.168.1.2
...
0	F	192.168.1.15
1	0	192.168.1.16
...
1	F	192.168.1.31
2	0	192.168.1.32
...
F	F	192.168.1.255

2.4 Switch Factory Settings

- All DIP switches off.
- Rotary switch 0 setting = 1. Rotary switch 1 setting = 0.
- Configured IP address is 192.168.1.1

3 Installation Standards

3.1 Mechanical Installation/Dimensions

The Sigma-7Siec servo interface is based on the Sigma-7S EtherCAT servo amplifier. As such, it has the same envelope and mechanical installation directions. Please refer to section 2.3 of the Sigma-7S EtherCAT (CoE) Communications Reference Product Manual (document number SIEPS80000155)

3.2.1 200V SERVOPACKS

3.2 Installing Multiple SERVOPACKS in a Control Panel

3.2.1 200V SERVOPACKS

Provide the following intervals between the SERVOPACKs and spaces around the SERVOPACKs.



Important Install cooling fans above the SERVOPACKs so that hot spots do not occur around the SERVOPACKs. Provide sufficient intervals and spaces as shown in the following figure to enable cooling by the fans and natural convection.

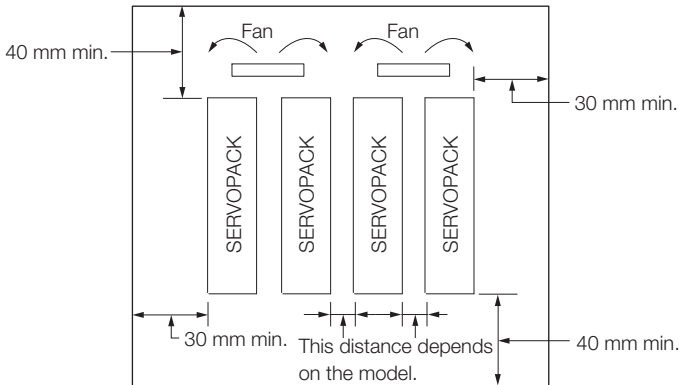

The space required on the right side of a SERVOPACK (when looking at the SERVOPACK from the front) depends on the SERVOPACK models. Refer to the following table.

SERVOPACK Model		Space on Right Side	Cooling Fan Installation Conditions
			10 mm above SERVOPACK's Top Surface
SGD7S-	R70A, R90A, 1R6A, 2R8A, 3R8A, 5R5A, 7R6A, R70F, R90F, 2R1F, 2R8F	1 mm min.	Air speed: 1.0 m/s min.
	120A, 180A, 200A, 330A, 470A, 550A, 590A, 780A	10 mm min.	Air speed: 1.0 m/s min.

3.2.2 400V SERVOPACKS

400 V SERVOPACKS can be mounted side-by-side as shown.



Install cooling fans above the SERVOPACKs so that hot spots do not occur around the SERVOPACKs.

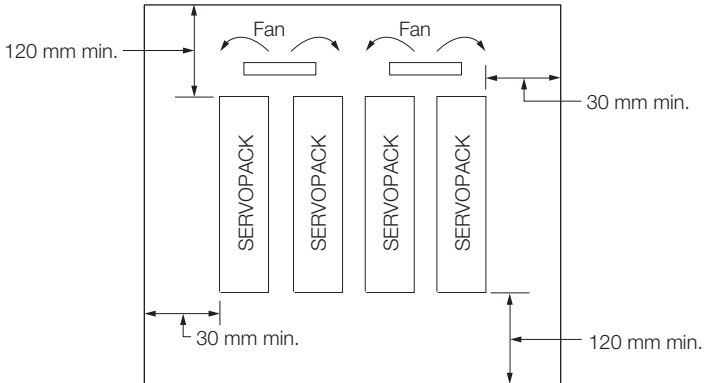

SERVOPACK Model	Cooling Fan Installation Conditions	
	10 mm above SERVOPACK's Top Surface	
SGD7S- 1R9D, 3R5D, 5R4D, 8R4D, 120D, 170D, 210D, 260D, 280D, 370D	Air speed: 1.0 m/s min.	

3.2.2 400V SERVOPACKS

4 Inputs and Outputs

4.1 Input Signals

4.1.1 200V SERVOPACKS

Default settings are provided in parentheses

Signal	Pin No.	Name	Function
/SI1 (P-OT)	7	General-purpose Sequence Input 1 (Forward Drive Prohibit Input)	You can allocate the input signal to use with a parameter. (Stops Servomotor drive (to prevent over-travel) when the moving part of the machine exceeds the range of movement.)
/SI2 (N-OT)	8	General-purpose Sequence Input 2 (Reverse Drive Prohibit Input)	
/SI3	9	General-purpose Sequence Input 3	You can allocate the input signal to use with parameters. (Used for general-purpose input.)
/SI4 (/EXT1)	10	External latch signal 1 input (General purpose input 4)	You can allocate the input signals to use with parameters.
/SI5 (/EXT2)	11	External latch signal 2 input (General purpose input 5)	
/SI6 (/EXT3)	12	External latch signal 3 input (General purpose input 6)	
/SI0	13	General-purpose Sequence Input 0	You can allocate the input signal to use with a parameter. (Used for general-purpose input.)
+24VIN	6	Sequence Input Signal Power Supply Input	Inputs the sequence input signal power supply. Allowable voltage range: 24 VDC \pm 20% The 24-VDC power supply is not provided by Yaskawa.
BAT+	14	Battery for Absolute Encoder (+)	These are the pins to connect the absolute encoder backup battery. Do not connect these pins if you use the Encoder Cable with a Battery Case.
BAT-	15	Battery for Absolute Encoder (-)	
TH	5	Linear Servomotor Overheat Protection Input	Inputs the overheat protection signal from a Linear Servomotor.

Note: If forward drive prohibition or reverse drive prohibition is used, the SERVOPACK is stopped by software controls. If the application does not satisfy the safety requirements, add external safety circuits as required.

4.1.2 400V SERVOPACKS

Default settings are given in parentheses.

Signal	Pin No.	Name	Function
/SI1 (P-OT)	7	General-purpose Sequence Input 1 (For- ward Drive Prohibit Input)	You can allocate the input signal to use with a parameter. (Stops Servomotor drive (to prevent overtravel) when the moving part of the machine exceeds the range of movement.)
/SI2 (N-OT)	8	General-purpose Sequence Input 2 (Reverse Drive Prohibit Input)	
/SI3	9	General-purpose Sequence Input 3	You can allocate the input signal to use with parameters. (Used for general-purpose input.)
/SI4 (/Probe1)	10	General-purpose Sequence Input 4 (Probe 1 Latch Input)	You can allocate the input signals to use with parameters. (Connect the external signals that latch the current feedback pulse counter.)
/SI5 (/Probe2)	11	General-purpose Sequence Input 5 (Probe 2 Latch Input)	
/SI6 (/Home)	12	General-purpose Sequence Input 6 (Home Switch Input)	You can allocate the input signal to use with parameters. (Connect the switch that starts homing.)
/SI0	13	General-purpose Sequence Input 0	You can allocate the input signal to use with a parameter. (Used for general-purpose input.)
+24VIN	6	Sequence Input Signal Power Supply Input	Inputs the sequence input signal power supply. Allowable voltage range: 24 VDC \pm 20% The 24- VDC power supply is not provided by Yaskawa.
BAT+	14	Battery for Absolute Encoder (+)	These are the pins to connect the absolute encoder backup battery. Do not connect these pins if you use the Encoder Cable with a Battery Case.
BAT-	15	Battery for Absolute Encoder (-)	
TH	5	Linear Servomotor Overheat Protection Input	Inputs the overheat protection signal from a Lin- ear Servomotor.

Note: If forward drive prohibition or reverse drive prohibition is used, the SERVOPACK is stopped by software controls. If the application does not satisfy the safety requirements, add external safety circuits as required.

4.2 Output Signals

4.2.1 200V SERVOPACKS

Default settings are provided in parentheses.

Signal	Pin No.	Name	Function
ALM+	3	Servo Alarm Output	Turns OFF (opens) when an error is detected.
ALM-	4		
/SO1+ (/BK+)	1	General-purpose Sequence Output 1 (Brake Output)	You can allocate the output signal to use with a parameter. (Controls the brake. The brake is released when the signal turns ON (closes).)
/SO1- (/BK-)	2		
/SO2+	23	General-purpose Sequence Output 2	Used for general-purpose outputs. Set the parameters to allocate functions.
/SO2-	24		
/SO3+	25	General-purpose Sequence Output 3	
/SO3-	26		
PAO	17	Encoder Divided Pulse Output, Phase A	Output the encoder divided pulse output signals with a 90° phase differential.
/PAO	18		
PBO	19	Encoder Divided Pulse Output, Phase B	
/PBO	20		
PCO	21	Encoder Divided Pulse Output, Phase C	Outputs the origin signal once every encoder rotation.
/PCO	22		
SG	16	Signal ground	This is the 0-V signal for the control circuits.
FG	Shell	Frame ground	Connected to the frame ground if the shield of the I/O Signal Cable is connected to the connector shell.

4.2.2 400V SERVOPACKS

Default settings are provided in parentheses.

Signal	Pin No.	Name	Function	
ALM+	3	Servo Alarm Output	Turns OFF (opens) when an error is detected.	
ALM-	4			
/SO1+ (/BK+)	1	General-purpose Sequence Output 1 (Brake Output)	You can allocate the output signal to use with a parameter. (Controls the brake. The brake is released when the signal turns ON (closes).)	
/SO1- (/BK-)	2			
/SO2+	23	General-purpose Sequence Output 2	Used for general-purpose outputs. Set the parameters to allocate functions.	
/SO2-	24			
/SO3+	25	General-purpose Sequence Output 3		
/SO3-	26			
/SO4+	27	General-purpose Sequence Output 4		
/SO4-	28			
/SO5+	29	General-purpose Sequence Output 5		
/SO5-	30			
PAO	17	Encoder Divided Pulse Output, Phase A		Output the encoder divided pulse output signals with a 90° phase differential.
/PAO	18			
PBO	19	Encoder Divided Pulse Output, Phase B		
/PBO	20			

4.3 I/O Signal Connector (CN1) Pin Arrangement

4.3.1 200V SERVOPACKS

The following figure gives the pin arrangement of the of the I/O signal connector (CN1) for the default settings.

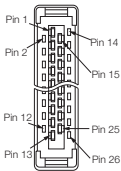

The above view is from the direction of the following arrow without the connector shell attached.

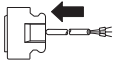

2	/SO1- (/BK-)	General-purpose Sequence Output 1	1	/SO1+ (/BK+)	General-purpose Sequence Output 1	15	BAT-	Battery for Absolute Encoder (-)	14	BAT+	Battery for Absolute Encoder (+)
4	ALM-	Servo Alarm Output	3	ALM+	Servo Alarm Output	17	PAO	Encoder Divided Pulse Output, Phase A	16	SG	Signal Ground
6	+24V N	Sequence Input Signal Power Supply Input	5	TH	Linear Servomotor Overheat Protection Input	19	PBO	Encoder Divided Pulse Output, Phase B	18	/PAO	Encoder Divided Pulse Output, Phase A
8	/SI2 (N-OT)	General-purpose Sequence Input 2	7	/SI1 (P-OT)	General-purpose Sequence Input 1	21	PCO	Encoder Divided Pulse Output, Phase C	20	/PBO	Encoder Divided Pulse Output, Phase B
10	/SI4 (/EXT1)	External latch signal 1 input (General purpose input 4)	9	/SI3 (/DEC)	General-purpose Sequence Input 3	23	/SO2+	General-purpose Sequence Output 2	22	/PCO	Encoder Divided Pulse Output, Phase C
12	/SI6 (/EXT3)	External latch signal 3 input (General purpose input 6)	11	/SI5 (/EXT2)	External latch signal 2 input (General purpose input 5)	25	/SO3+	General-purpose Sequence Output 3	24	/SO2-	General-purpose Sequence Output 2
			13	/SI0	General-purpose Sequence Input 0				26	/SO3-	General-purpose Sequence Output 3

4.3.2 400V SERVOPACKS

The following figure gives the pin arrangement of the of the I/O signal connector (CN1) for the default settings.

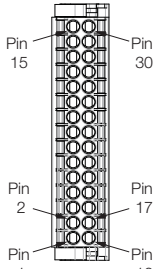

Top View of I/O Signal Connector



Side View of I/O Signal Connector

No	Signal	Specification	No	Signal	Specification
15	PG BAT-	Battery for absolute encoder (-)	30	/SO5-	General-purpose sequence output 5
14	PG BAT+	Battery for absolute encoder (+)	29	/SO5+	General-purpose sequence output 5
13	/SI0	General-purpose sequence input 0	28	/SO4-	General-purpose sequence output 4
12	/SI6 (/Home)	General-purpose sequence input 6	27	/SO4+	General-purpose sequence output 4
11	/SI5 (/Probe2)	General-purpose sequence input 5	26	/SO3-	General-purpose sequence output 3
10	/SI4 (/Probe1)	General-purpose sequence input 4	25	/SO3+	General-purpose sequence output 3
9	/SI3	General-purpose sequence input 3	24	/SO2-	General-purpose sequence output 2
8	/SI2 (N-OT)	General-purpose sequence input 2	23	/SO2+	General-purpose sequence output 2
7	/SI1 (P-OT)	General-purpose sequence input 1	22	/PCO	Encoder divided pulse output, phase C
6	+24VIN	Sequence input signal power supply input	21	PCO	Encoder divided pulse output, phase C
5	TH	Linear Servomotor overheat protection input	20	/PBO	Encoder divided pulse output, phase B
4	ALM-	Servo alarm output	19	PBO	Encoder divided pulse output, phase B
3	ALM+	Servo alarm output	18	/PAO	Encoder divided pulse output, phase A
2	/SO1- (/BK-)	General-purpose sequence output 1	17	PAO	Encoder divided pulse output, phase A
1	/SO1+ (/BK+)	General-purpose sequence output 1	16	SG	Signal ground

4.4 I/O Signal Wiring Examples

4.4.1 Using a Rotary Servo Motor

200V SERVOPACKS

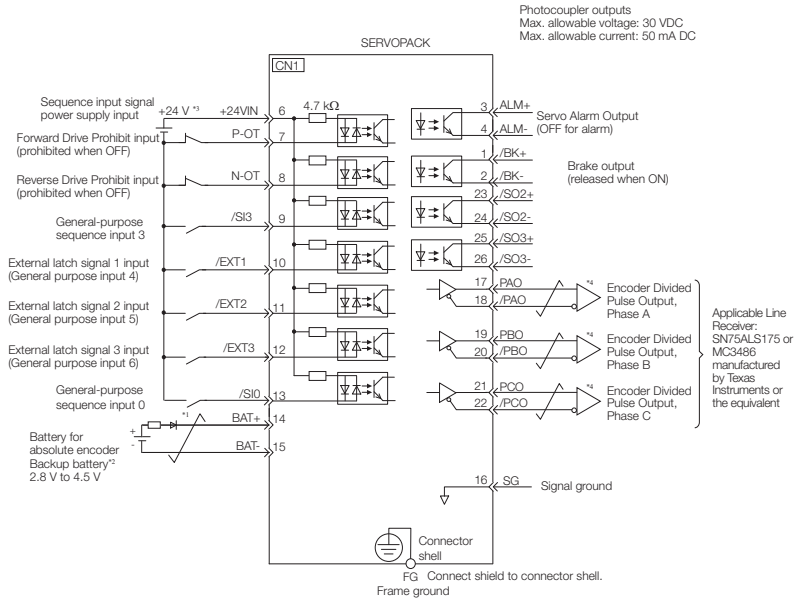

* 1.  represents twisted-pair wires.

* 2. Connect these when using an absolute encoder. If the Encoder Cable with a Battery Case is connected, do not connect a backup battery.

* 3. The 24-VDC power supply is not provided by Yaskawa. Use a 24-VDC power supply with double insulation or reinforced insulation.

* 4. Always use line receivers to receive the output signals.

Note: 1. You can use parameters to change the functions allocated to the /SI0, /SI3, P-OT, N-OT, /EXT1, /EXT2, and /EXT3 input signals and the /SO1, /SO2, and /SO3 output signals.

2. If you use a 24-V brake, install a separate power supply for the 24-VDC power supply from other power supplies, such as the one for the I/O signals of the CN1 connector.

If the power supply is shared, the I/O signals may malfunction.

4.4.1 Using a Rotary Servo Motor

400V SERVOPACKS

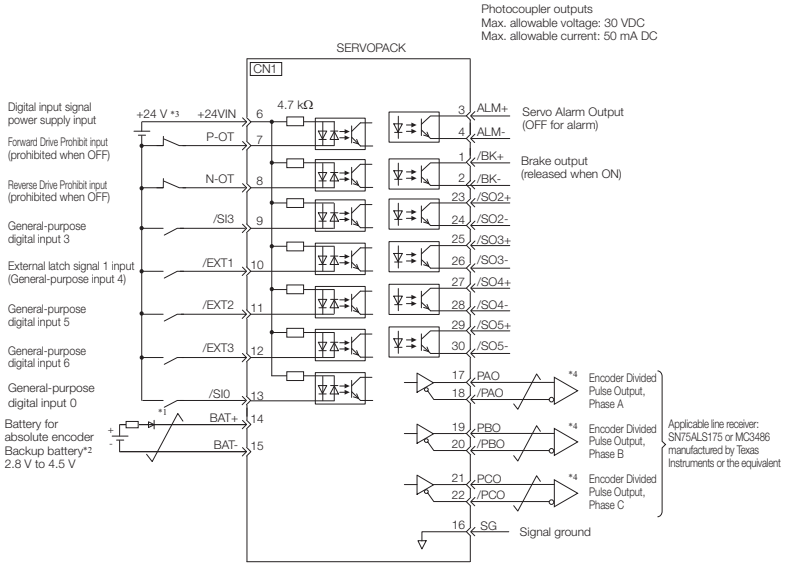

- * 1. represents twisted-pair wires.
- * 2. Connect these when using an absolute encoder. If the Encoder Cable with a Battery Case is connected, do not connect a backup battery.
- * 3. The 24-VDC power supply is not provided by Yaskawa. Use a 24-VDC power supply with double insulation or reinforced insulation.
- * 4. Always use line receivers to receive the output signals.

Note: 1. You can use parameters to change the functions allocated to the /SI0, /SI3, P-OT, N-OT, /EXT1, /EXT2, and /EXT3 input signals and the /SO1, /SO2, and /SO3 output signals.

2. If you use a 24-V brake, install a separate power supply for the 24-VDC power supply from other power supplies, such as the one for the I/O signals of the CN1 connector. If the power supply is shared, the I/O signals may malfunction.

4.4.2 Using a Linear Servo Motor

200V SERVOPACKS

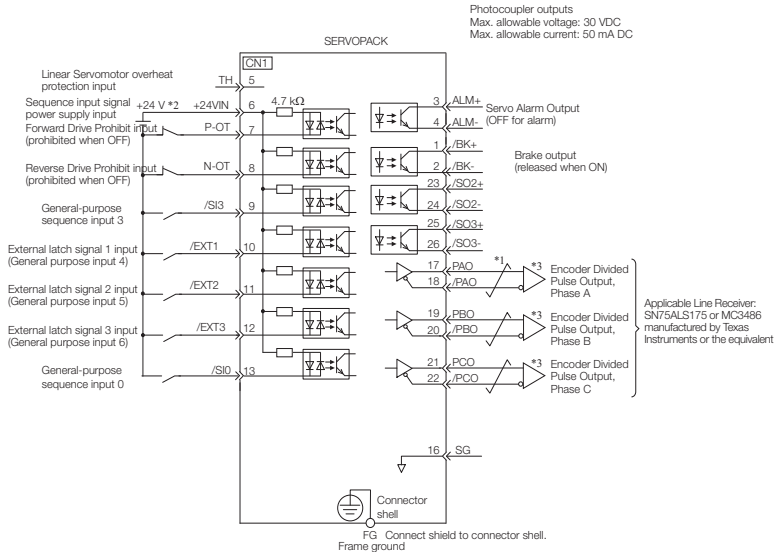

* 1.  represents twisted-pair wires.

* 2. The 24-VDC power supply is not provided by Yaskawa. Use a 24-VDC power supply with double insulation or reinforced insulation.

* 3. Always use line receivers to receive the output signals.

Note: 1. You can use parameters to change the functions allocated to the /SI0, /SI3, P-OT, N-OT, /EXT1, /EXT2, and /EXT3 input signals and the /SO1, /SO2, and /SO3 output signals.

2. If you use a 24-V brake, install a separate power supply for the 24-VDC power supply from other power supplies, such as the one for the I/O signals of the CN1 connector.

If the power supply is shared, the I/O signals may malfunction.

400V SERVOPACKS

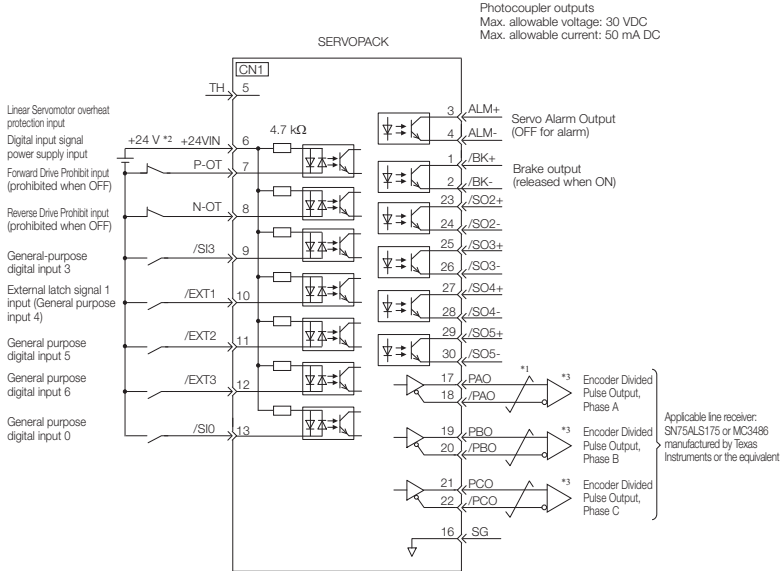

* 1.  represents twisted-pair wires.

* 2. The 24-VDC power supply is not provided by Yaskawa. Use a 24-VDC power supply with double insulation or reinforced insulation.

* 3. Always use line receivers to receive the output signals.

Note: 1. You can use parameters to change the functions allocated to the /SI0, /SI3, P-OT, N-OT, /EXT1, /EXT2, and /EXT3 input signals and the /SO1, /SO2, and /SO3 output signals.

2. If you use a 24-V brake, install a separate power supply for the 24-VDC power supply from other power supplies, such as the one for the I/O signals of the CN1 connector.

If the power supply is shared, the I/O signals may malfunction.

4.5 I/O Circuits

4.5.1 Sequence Input Circuits

◆ Photocoupler Input Circuits

This section describes CN1 connector terminals 6 to 13.

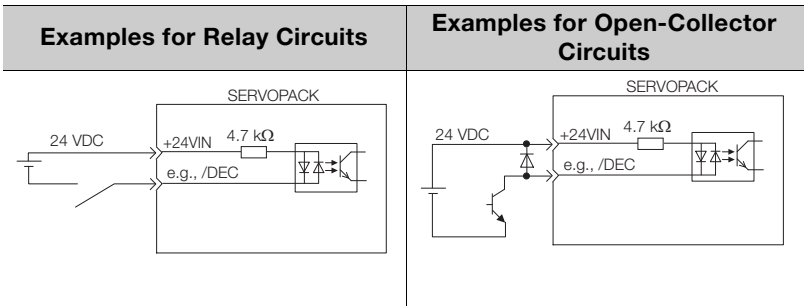

Note: The 24-VDC external power supply capacity must be 50 mA minimum.

The SERVOPACK input circuits use bi-directional photocouplers. Select either a sink circuit or source circuit according to the specifications required by the machine.

Note: The connection examples in 4.4 I/O Signal Wiring Examples are for sink circuit connections.

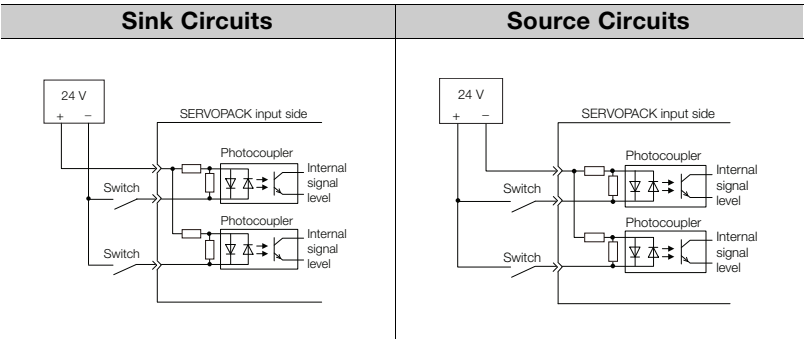

Input Signal Polarity		Input Signal Polarity	
Photocoupler	Internal Signal Level	Photocoupler	Internal Signal Level
ON	Low level	ON	Low level
OFF	High level	OFF	High level

4.5.2 Sequence Output Circuits



Important

Incorrect wiring or incorrect voltage application to the output circuits may cause short-circuit failures. If a short-circuit failure occurs as a result of any of these causes, the holding brake will not work. This could damage the machine or cause an accident that may result in death or injury.

◆ Photocoupler Output Circuits

Photocoupler output circuits are used for the ALM (Servo Alarm), /S-RDY (Servo Ready), and other sequence output signals. Connect a photocoupler output circuit to a relay or line-receiver circuit.

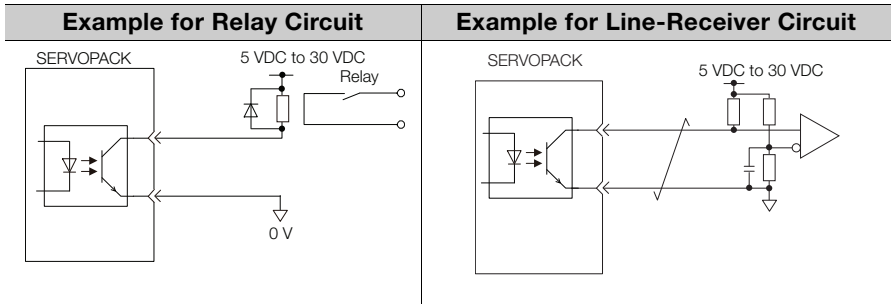

Note: The maximum allowable voltage and current range for photocoupler output circuits are as follows:

- Maximum allowable voltage: 30 VDC
- Current range: 5 mA to 50 mA DC

◆ Line-Driver Output Circuits

This section describes CN1 connector terminals 17-18 (Phase-A Signal), 19-20 (Phase-B Signal), and 21-22 (Phase-C Signal).

The serial data from the encoder is converted to two-phase (phases A and B) pulses. The resulting output signals (PAO, /PAO and PBO, /PBO) and origin pulse signal (PCO and /PCO) are output with line-driver output circuits. Connect the line-driver output circuits to line-receiver circuits at the host controller.

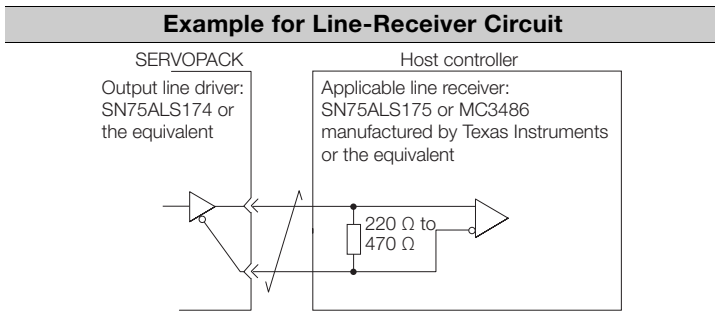

5 LED Outputs

The following indicators show the operating status of the servo controller and error information.

ERR:

- Solid at power up
- Off when there is no error
- Solid when there is an alarm
- Blinking when there is a critical error

RUN:

- Solid when internal logic controller is booted and ready
- Blinking when internal logic controller is running a program

Ethernet Link/Activity:

- Off when CN6A/B does not have an active Ethernet connection
- Solid when CN6A/B has an active Ethernet connection
- Blinking when CN6A/B is transmitting or receiving data

6 Ethernet Connectivity

The Sigma-7Siec supports both 100 Mbps/100Base-TX and 10 Mbps/10Base-T connections. One single network is accessed using both CN6A and CN6B. The same IP address is set for both ports. The Ethernet address (MAC address) can be found on the nameplate.

6.1 Ethernet Connector Details

Ethernet Connector Specification and Pin Array

The following table provides the Ethernet connector specifications.

Connector Name	Number of Pins	Connector Model		
		Module Side	Cable Side	Manufacturer
Ethernet	8	RJ-45 CAT5 Socket	RJ-45 CAT5 Plug	TE Connectivity

The following table provides Ethernet connector pin array details.



Pin Number	Signal Name	Description
1	TXD+	Transmitted data + side
2	TXD-	Transmitted data – side
3	RXD+	Received data + side
4	–	–
5	–	–
6	RXD-	Received data – side
7	–	–
8	–	–

6.2 Ethernet Cable

For the Ethernet cable, use a twisted pair cable with RJ-45 connector. Yaskawa strongly recommends the use of shielded ethernet cables (Yaskawa model JZSP-CM3RRM0-xx-E). Ethernet ports are capable of auto-crossover, so crossover cables are not necessary.

6.3 Ethernet Connection Examples

Connection Example 1

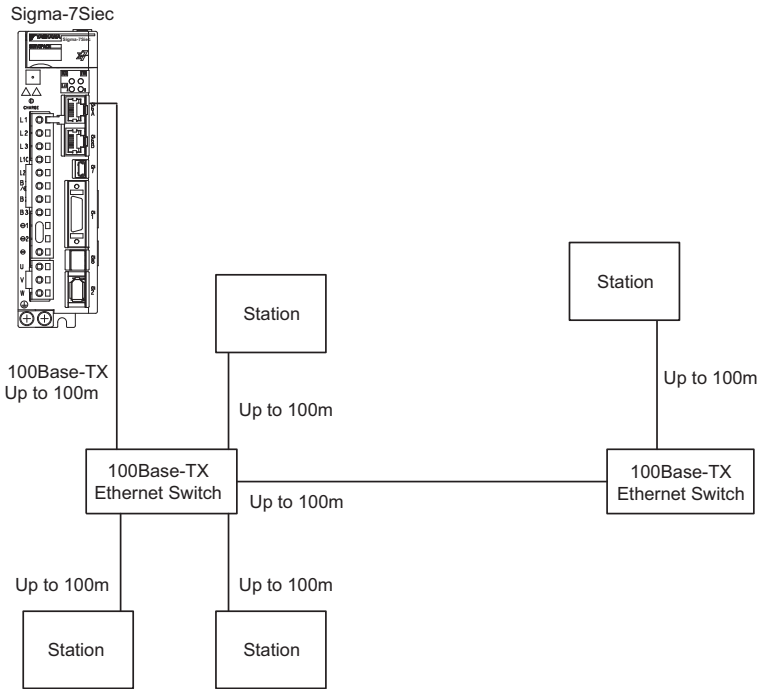

Specification

Cable length from node to Ethernet hub or switch	100 m or less
Cable length between Ethernet hubs or switches	100 m or less
Number of Ethernet hubs or switches between nodes	Unlimited

Connection Example 2

Sigma-7Siec

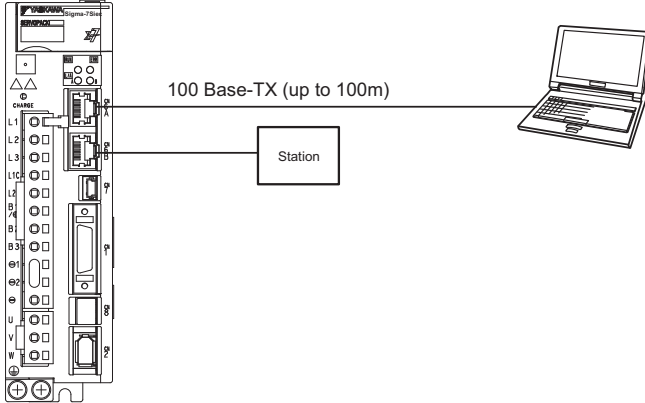

Connection Example 3

Sigma-7Siec

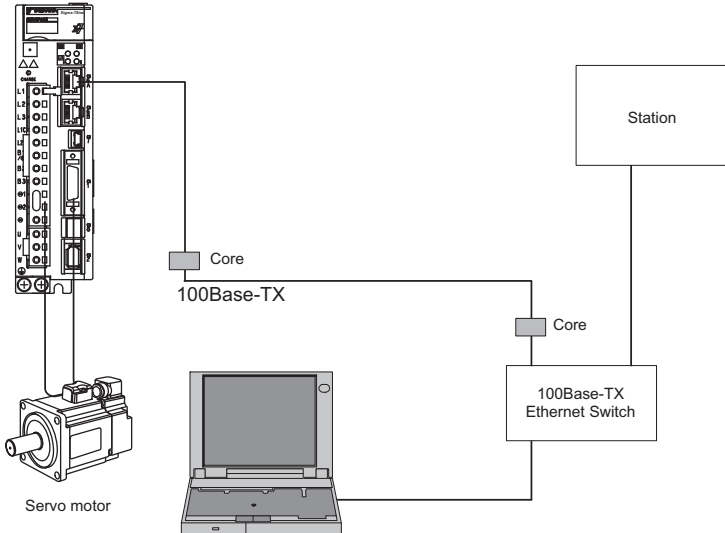

■ Caution

Electromagnetic interference (EMI) may interfere with Ethernet communication. The following measures can help minimize the influence of EMI:

1. Locate Ethernet cables so that they are well-separated from power cables or other sources of EMI
2. Yaskawa strongly recommends the use of high-quality shielded Ethernet cables such as JZSP-CM3RRM0-xx-E
3. Attach ferrite cores to Ethernet cables that are subjected to EMI



Recommended ferrite core:

Model	Manufacturer
E04SR301334	Seiwa Electric Mfg. Co., Ltd

7 Cable Diagrams

7.1 SBK-U-VBA-xx (200V Only)

Terminal Block - CN1 I/O.

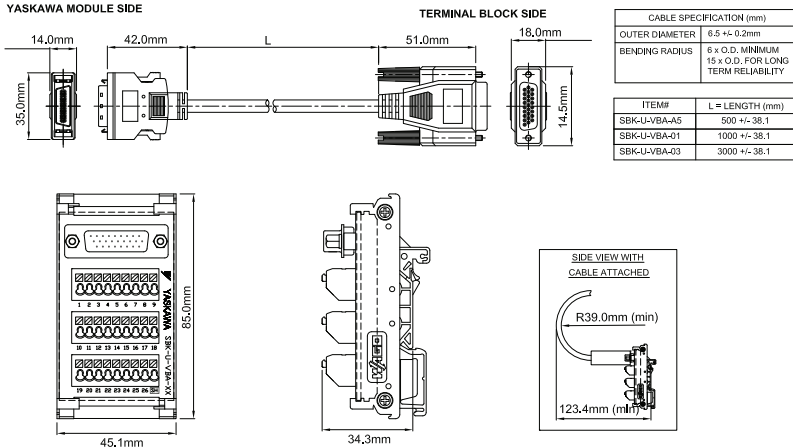

SBK-U-VBA-xx Function Chart for Sigma-5 or Sigma-7 Servo Amplifier

Pin No.	Mechatrolink-II type Servo Amplifier / Option type	
	Signal	Function
1	/BK+ (/SO1+)	Brake interlock output (+) (General purpose output 1 (+))
2	/BK- (/SO1-)	Brake interlock output (-) (General purpose output 1 (-))
3	ALM+	Servo alarm output (+)
4	ALM-	Servo alarm output (-)
5	-	
6	+24VIN	Control power supply for sequence signal input
7	P-OT (/SI1)	Forward run prohibited input (General purpose input 1)
8	N-OT (/SI2)	Reverse run prohibited input (General purpose input 2)
9	/DEC (/SI3)	Zero-point return deceleration switch input (General purpose input 3)
10	/EXT1 (/SI4)	External latch signal 1 input (General purpose input 4)
11	/EXT2 (/SI5)	External latch signal 2 input (General purpose input 5)
12	/EXT3 (/SI6)	External latch signal 3 input (General purpose input 6)
13	/SI0	General purpose input 0
14	BAT (+)	Battery (+) input
15	BAT (-)	Battery (-) input
16	SG	Signal ground
17	PAO	Phase-A pulse output (+)
18	/PAO	Phase-A pulse output (-)
19	PBO	Phase-B pulse output (+)
20	/PBO	Phase-B pulse output (-)
21	PCO	Phase-C pulse output (+)
22	/PCO	Phase-C pulse output (-)
23	/SO2+	General purpose output 2 (+)
24	/SO2-	General purpose output 2 (-)
25	/SO3+	General purpose output 3 (+)
26	/SO3-	General purpose output 3 (-)

Note: General purpose input and output signals are shown with their default signals assigned - signal assignment may have been changed by parameter

7.2 JZSP-CSI02-x-E (200V Only)

Flying Lead - CN1 I/O.

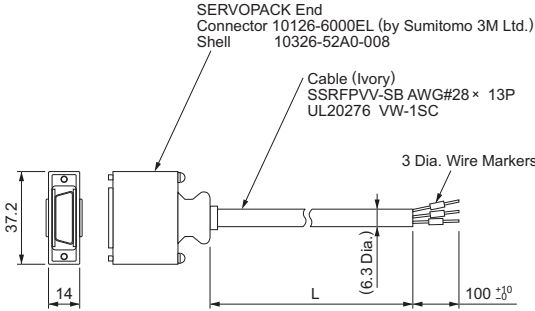

Dimensions in mm

Model	Cable Length
JZSP-CSI02-1-E	1000 mm
JZSP-CSI02-2-E	2000 mm
JZSP-CSI02-3-E	3000 mm

Pin No.	Signal	Wire Color	Marking		Host Controller End	Lead Marker
			Color	Dots		
1	/BK+	Blue	Red	1		1
2	/BK-	Blue	Black	1		2
3	ALM+	Pink	Red	1		3
4	ALM-	Pink	Black	1		4
5	-	Green	Red	1		5
6	+24VIN	Green	Black	1		6
7	P-OT	Orange	Red	1		7
8	N-OT	Orange	Black	1		8
9	/DEC	Gray	Red	1		9
10	/EXT1	Gray	Black	1		10
11	/EXT2	Blue	Red	2		11
12	/EXT3	Blue	Black	2		12
13	/SIO	Pink	Red	2		13
14	BAT (+)	Green	Red	2		14
15	BAT (-)	Green	Black	2		15
16	SG	Pink	Black	2		16
17	PAO	Orange	Red	2		17
18	/PAO	Orange	Black	2		18
19	PBO	Gray	Red	2		19
20	/PBO	Gray	Black	2		20
21	PCO	Blue	Red	3		21
22	/PCO	Blue	Black	3		22
23	/SO2+	Pink	Red	3		23
24	/SO2-	Pink	Black	3		24
25	/SO3+	Green	Red	3		25
26	/SO3-	Green	Black	3		26

: Represents twisted-pair wires.

8 EMC Installation Conditions

This section gives the installation conditions that were used for EMC certification testing.

The EMC installation conditions that are given here are the conditions that were used to pass testing criteria at Yaskawa. The EMC level may change under other conditions, such as the actual installation structure and wiring conditions. These Yaskawa products are designed to be built into equipment. Therefore, you must implement EMC measures and confirm compliance for the final equipment.

The applicable standards are EN 55011 group 1 class A, EN 61000-6-2, EN 61000-6-4, and EN 61800-3 (category C2, second environment).

- **Three-Phase, 200 VAC**

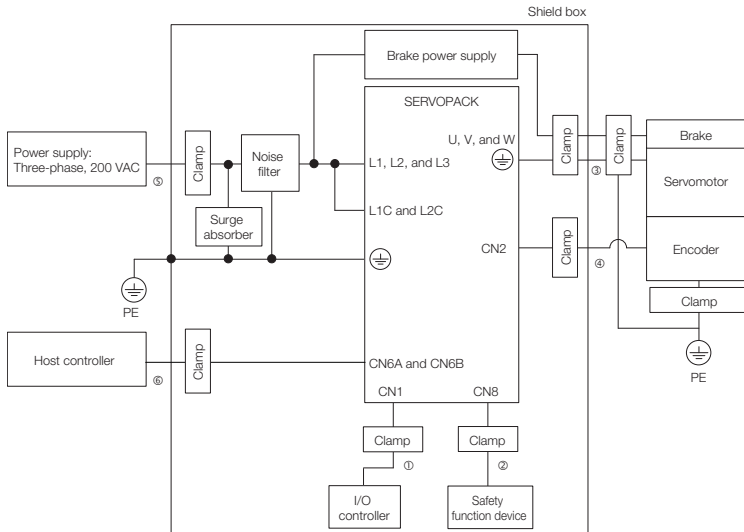

Symbol	Cable Name	Specification
①	I/O Signal Cable	Shielded cable
②	Safety Function Device Cable	Shielded cable
③	Servomotor Main Circuit Cable	Shielded cable
④	Encoder Cable	Shielded cable
⑤	Main Circuit Power Cable	Shielded cable
⑥	Ethernet Communications Cable	Shielded cable

• **Single-Phase, 200 VAC**

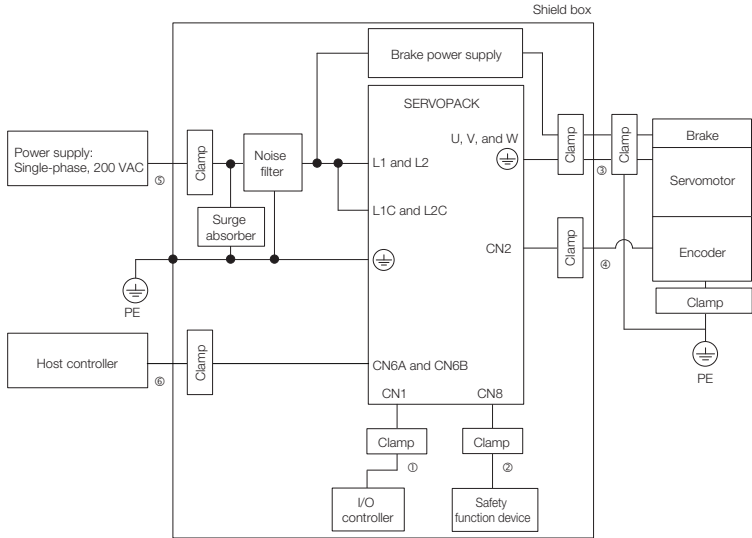

Symbol	Cable Name	Specification
①	I/O Signal Cable	Shielded cable
②	Safety Function Device Cable	Shielded cable
③	Servomotor Main Circuit Cable	Shielded cable
④	Encoder Cable	Shielded cable
⑤	Main Circuit Power Cable	Shielded cable
⑥	Ethernet Communications Cable	Shielded cable

• Single-Phase, 100 VAC

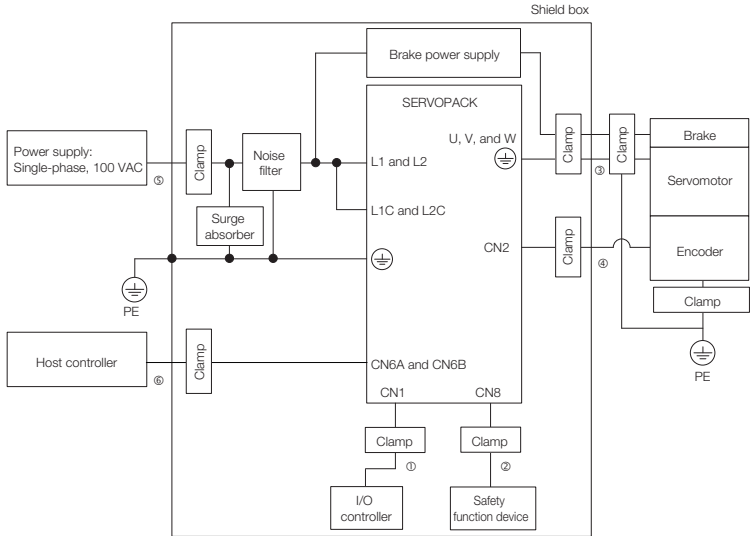

Symbol	Cable Name	Specification
①	I/O Signal Cable	Shielded cable
②	Safety Function Device Cable	Shielded cable
③	Servomotor Main Circuit Cable	Shielded cable
④	Encoder Cable	Shielded cable
⑤	Main Circuit Power Cable	Shielded cable
⑥	Ethernet Communications Cable	Shielded cable

• Three-Phase, 400 VAC

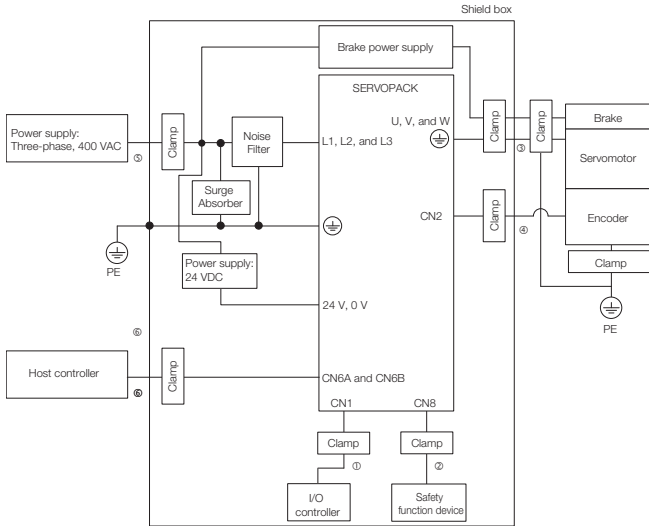

Symbol	Cable Name	Specification
①	I/O Signal Cable	Shielded cable
②	Safety Function Device Cable	Shielded cable
③	Servomotor Main Circuit Cable	Shielded cable
④	Encoder Cable	Shielded cable
⑤	Main Circuit Power Supply Cable	Shielded cable
⑥	Ethernet Communications Cable	Shielded cable

9 Safety

9.1 Safety Modules

The Sigma-7Siec can support safety functions in combination with the following Safety Module for Σ -V Series, Large-Capacity Σ -V Series, and Σ -7 Series SERVOPACKs:

- “SGDV-OSA01A” for 200V Sigma-7Siec
- “SGDV-OSA01A000FT900” for 400V Sigma-7Siec

9.2 Safety Module Installation

For the installation procedure of SGDV-OSA01A, please refer to the Σ -V Series/ Σ -V Series for Large-Capacity Models/ Σ -7 Series Safety Module Installation Guide (document number TOBPC72082906)

For the installation procedure of SGDV-OSA01A000FT900, please refer to the Σ -V Series AC SERVOPACK Safety Module with FT900 Specification Installation Guide (document number TOBPC72082909)

9.3 Supported Safety Functions

The Sigma-7Siec on its own supports Hard Wire Base Block (HWBB) Safety function. For more information on HWBB, please see section 11 in Σ -7S SERVOPACK with EtherCAT (CoE) Communications Reference Product Manual (document number SIEPS80000155).

The Sigma-7Siec also supports other safety functions in combination with the safety modules mentioned above. For more details, please see section 6 in the Safety Module for Σ -V Series, Large-Capacity Σ -V Series, and Σ -7 Series SERVOPACKs User's Manual (document number SIEPC72082906).

9.4 Relationship with Function Blocks for Motion

If the Sigma-7Siec changes to the HWBB state during operation due to motion commanded by function blocks, a “4400h: Hard Wire Base Block” error will occur.

If this error occurs, user can turn off “Enable” input of MC_Power function block, turn on the /HWBB1 and /HWBB2 signals (Safety request input signals in case of SBB) and turn on “Enable” input of MC_Power function block. After completing these steps, the HWBB error will be cleared and operation can resume.

9.5 Risk Assessment

When using the Safety Module, be sure to perform risk assessment of the servo system in advance. Make sure that the safety level of the standards is met. For details about the standards, refer to front of this manual.

The following residual risks can be present even when the safety functions operate. Therefore, safety must always be given consideration during risk assessment.

- If external forces (such as gravitational force with a vertical axis) are applied when the safety functions of the Safety Module are operating, the motor will rotate due to the action of these external forces. Provide a separate mechanical brake to secure the motor.
- If the SERVOPACK fails, the motor may operate within a range of 180 electrical degrees. Make sure that safety is ensured even in hazardous situations.
- The number of rotations and movement distance for each type of motor are listed below.
 - Rotational Servomotor: 1/6 rotation max. (Rotation angle at motor shaft conversion)
 - Direct Drive Motor: 1/20 rotation max. (Rotation angle at motor shaft conversion)
 - Linear Servomotor: 30 mm max.

**IRUMA BUSINESS CENTER (SOLUTION CENTER)**

480, Kamifujisawa, Iruma, Saitama, 358-8555, Japan
Phone: 81-4-2962-5696 Fax: 81-4-2962-6138

YASKAWA ELECTRIC CORPORATION

New Pier Takeshiba South Tower, 1-16-1, Kaigan, Minatoku, Tokyo, 105-6891, Japan
Phone: 81-3-5402-4511 Fax: 81-3-5402-4580
<http://www.yaskawa.co.jp>

YASKAWA AMERICA, INC.

2121 Norman Drive South, Waukegan, IL 60085, U.S.A.
Phone: (800) YASKAWA (800-927-5292) or 1-847-887-7000 Fax: 1-847-887-7310
<http://www.yaskawa.com>

YASKAWA ELÉTRICO DO BRASIL, LTDA.

Avenida Piraporinha 777, Diadema, São Paulo, 09950-000, Brasil
Phone: 55-11-3585-1100 Fax: 55-11-3585-1187
<http://www.yaskawa.com.br>

YASKAWA EUROPE GmbH

Philipp-Reis-Str. 6, 65795 Hattersheim, Germany
Phone: 49-6196-569-300 Fax: 49-6196-569-398

YASKAWA ELECTRIC UK LTD.

1 Hunt Hill Orchardton Woods, Cumbernauld, G68 9LF, United Kingdom
Phone: 44-1236-735000 Fax: 44-1236-458182

YASKAWA ELECTRIC KOREA CORPORATION

7F, Doore Bldg. 24, Yeoido-dong, Youngdungpo-Ku, Seoul, 150-877, Korea
Phone: 82-2-784-7844 Fax: 82-2-784-8495

YASKAWA ELECTRIC (SINGAPORE) PTE. LTD.

151 Lorong Chuan, #04-01, New Tech Park, 556741, Singapore
Phone: 65-6282-3003 Fax: 65-6289-3003

YASKAWA ELECTRIC (SHANGHAI) CO., LTD.

No. 18 Xizang Zhong Road, Room 1702-1707, Harbour Ring Plaza, Shanghai, 200001, China
Phone: 86-21-5385-2200 Fax: 86-21-5385-3299

YASKAWA ELECTRIC (SHANGHAI) CO., LTD. BEIJING OFFICE

Room 1011A, Tower W3 Oriental Plaza, No. 1 East Chang An Ave.,
Dong Cheng District, Beijing, 100738, China
Phone: 86-10-8518-4086 Fax: 86-10-8518-4082

YASKAWA ELECTRIC TAIWAN CORPORATION

9F, 16, Nanking E. Rd., Sec. 3, Taipei, Taiwan
Phone: 886-2-2502-5003 Fax: 886-2-2505-1280