

# X20(c)DO9322

## 1 General information

The module is equipped with 12 outputs for 1-wire connections. The module is designed for source output wiring.

- 12 digital outputs
- Source connection
- 1-wire connections
- Integrated output protection

## 2 Coated modules

Coated modules are X20 modules with a protective coating for the electronics component. This coating protects X20c modules from condensation and corrosive gases.

The modules' electronics are fully compatible with the corresponding X20 modules.

**For simplification purposes, only images and module IDs of uncoated modules are used in this data sheet.**

The coating has been certified according to the following standards:

- Condensation: BMW GS 95011-4, 2x 1 cycle
- Corrosive gas: EN 60068-2-60, method 4, exposure 21 days



## 3 Order data

Model number	Short description	Figure
	<b>Digital outputs</b>	
X20DO9322	X20 digital output module, 12 outputs, 24 VDC, 0.5 A, source, 1-wire connections	
X20cDO9322	X20 digital output module, coated, 12 outputs, 24 VDC, 0.5 A, source, 1-wire connections	
	<b>Required accessories</b>	
	<b>Bus modules</b>	
X20BM11	X20 bus module, 24 VDC keyed, internal I/O supply continuous	
X20BM15	X20 bus module, with node number switch, 24 VDC keyed, internal I/O supply continuous	
X20cBM11	X20 bus module, coated, 24 VDC keyed, internal I/O supply continuous	
	<b>Terminal blocks</b>	
X20TB12	X20 terminal block, 12-pin, 24 VDC keyed	

Table 1: X20DO9322, X20cDO9322 - Order data

## 4 Technical data

Model number	X20DO9322	X20cDO9322
<b>Short description</b>		
I/O module	12 digital outputs 24 VDC for 1-wire connections	
<b>General information</b>		
B&R ID code	0x1B9A	0xD578
Status indicators	I/O function per channel, operating state, module status	
Diagnostics		
Module run/error	Yes, using status LED and software	
Outputs	Yes, using status LED and software (output error status)	
Power consumption		
Bus	0.26 W	
Internal I/O	1.15 W	
Additional power dissipation caused by actuators (resistive) [W] <sup>1)</sup>	+0.63	
<b>Certifications</b>		
CE	Yes	
KC	Yes	-
UL	cULus E115267 Industrial control equipment	
HazLoc	cCSAus 244665 Process control equipment for hazardous locations Class I, Division 2, Groups ABCD, T5	
ATEX	Zone 2, II 3G Ex nA nC IIA T5 Gc IP20, Ta (see X20 user's manual) FTZÚ 09 ATEX 0083X	
DNV GL	Temperature: <b>B</b> (0 - 55°C) Humidity: <b>B</b> (up to 100%) Vibration: <b>B</b> (4 g) EMC: <b>B</b> (Bridge and open deck)	
LR	ENV1	
GOST-R	Yes	
<b>Digital outputs</b>		
Design	FET positive switching	
Nominal voltage	24 VDC	
Switching voltage	24 VDC -15 % / +20 %	
Nominal output current	0.5 A	
Total nominal current	6 A	
Connection type	1-wire connections	
Output circuit	Source	
Output protection	Thermal cutoff if overcurrent or short circuit occurs (see value "Peak short circuit current") Internal inverse diode for switching inductive loads (see section "Switching inductive loads")	
Diagnostic status	Output monitoring with 10 ms delay	
Leakage current when switched off	5 µA	
R <sub>DS(on)</sub>	210 mΩ	
Peak short circuit current	<12 A	
Switching on after overload or short circuit cutoff	Approx. 10 ms (depends on the module temperature)	
Switching delay <sup>2)</sup>		
0 → 1	<300 µs	
1 → 0	<300 µs	
Switching frequency		
Resistive load <sup>2)</sup>	Max. 500 Hz	
Inductive load	See section "Switching inductive loads"	
Braking voltage when switching off inductive loads	Typ. 50 VDC	
Isolation voltage between channel and bus	500 V <sub>eff</sub>	
<b>Electrical characteristics</b>		
Electrical isolation	Channel isolated from bus Channel not isolated from channel	
<b>Operating conditions</b>		
Mounting orientation		
Horizontal	Yes	
Vertical	Yes	
Installation elevation above sea level		
0 to 2000 m	No limitations	
>2000 m	Reduction of ambient temperature by 0.5°C per 100 m	
Degree of protection per EN 60529	IP20	

Table 2: X20DO9322, X20cDO9322 - Technical data

Model number	X20DO9322	X20cDO9322
<b>Environmental conditions</b>		
Temperature		
Operation		
Horizontal mounting orientation	-25 to 60°C	
Vertical mounting orientation	-25 to 50°C	
Derating	See section "Derating"	
Storage	-40 to 85°C	
Transport	-40 to 85°C	
Relative humidity		
Operation	5 to 95%, non-condensing	Up to 100%, condensing
Storage	5 to 95%, non-condensing	
Transport	5 to 95%, non-condensing	
<b>Mechanical properties</b>		
Note	Order 1x X20TB12 terminal block separately Order 1x X20BM11 bus module separately	Order 1x X20TB12 terminal block separately Order 1x X20cBM11 bus module separately
Spacing	12.5 <sup>+0.2</sup> mm	

Table 2: X20DO9322, X20cDO9322 - Technical data

- Number of outputs x  $R_{D(on)}$  x Nominal output current<sup>2</sup>. For a calculation example, see section "Mechanical and electrical configuration" of the X20 system user's manual.
- @  $\leq 1$  k $\Omega$

## 5 Status LEDs

For a description of the various operating modes, see section "Additional information - Diagnostic LEDs" of the X20 system user's manual.

Figure	LED	Color	Status	Description
	r	Green	Off	Module supply not connected
			Single flash	RESET mode
			Blinking	PREOPERATIONAL mode
			On	RUN mode
	e	Red	Off	Module supply not connected or everything OK
			Single flash	Warning/Error on an I/O channel. Level monitoring for digital outputs has been triggered.
	e + r	Red on / Green single flash	Invalid firmware	
	1 - 12	Orange		Output status of the corresponding digital output

## 6 Pinout

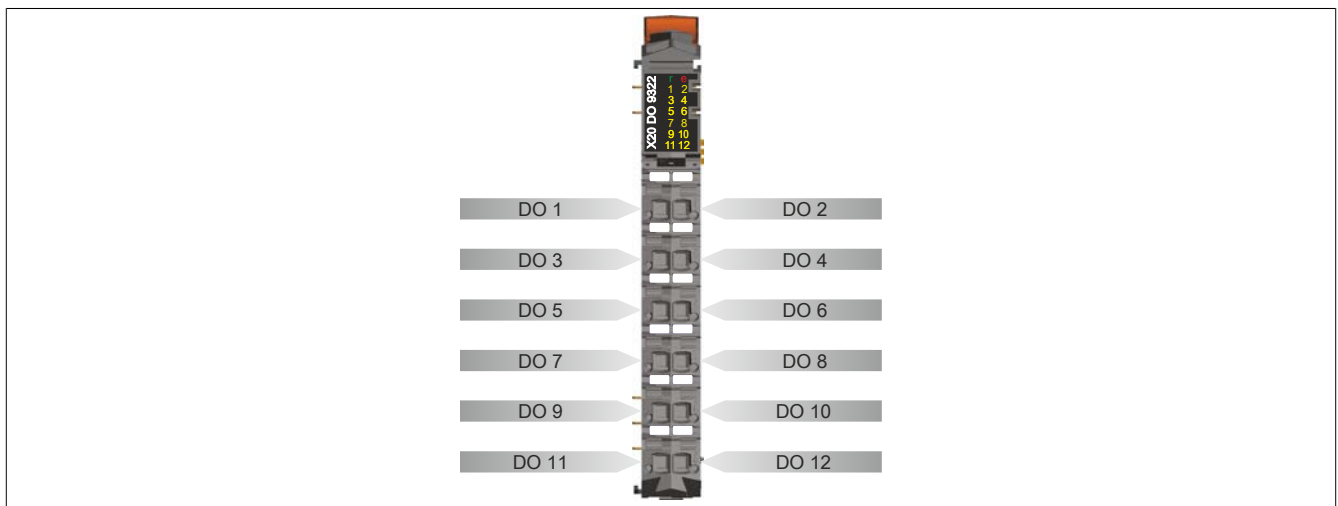

## 7 Connection example

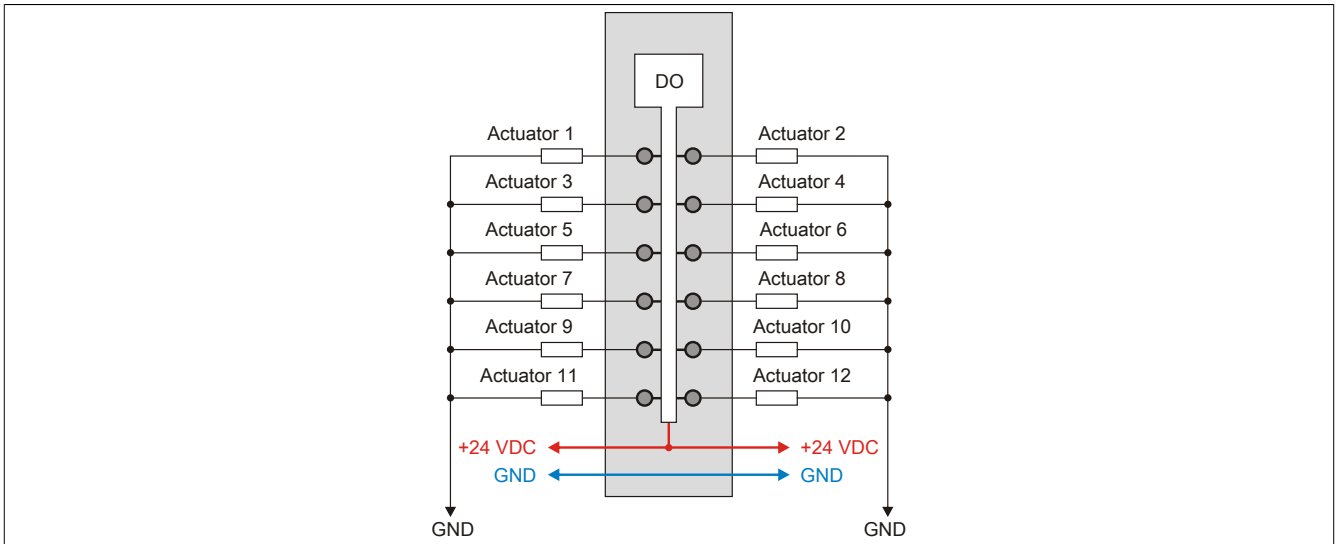

### Caution!

If the module is operated outside of specifications, the output current can increase above the maximum permissible nominal current. This applies to individual channels and also to the summation current for the module.

Therefore sufficient cable cross sections or external safety measures must be used.

## 8 Output circuit diagram

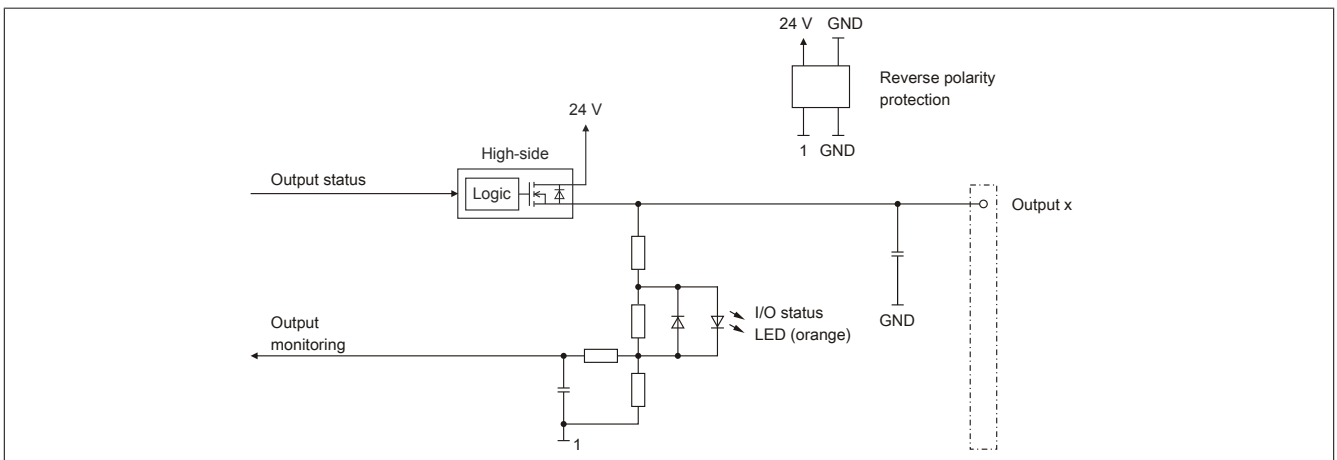

## 9 Derating

There is no derating when operated below 55°C.

When operated at temperatures above 55°C, the maximal total current per channel is limited to 0,35 A

## 10 Switching inductive loads

Environmental temperature: 55°C, all outputs with the same load

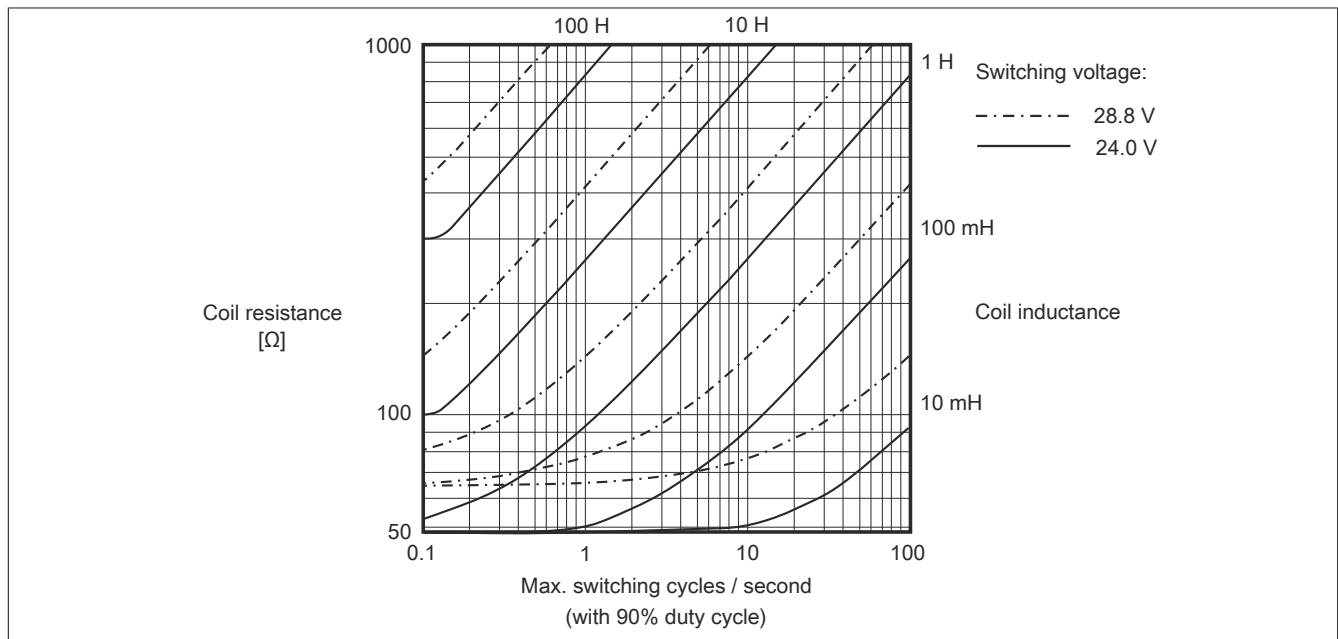

Environmental temperature: 60°C, all outputs with the same load

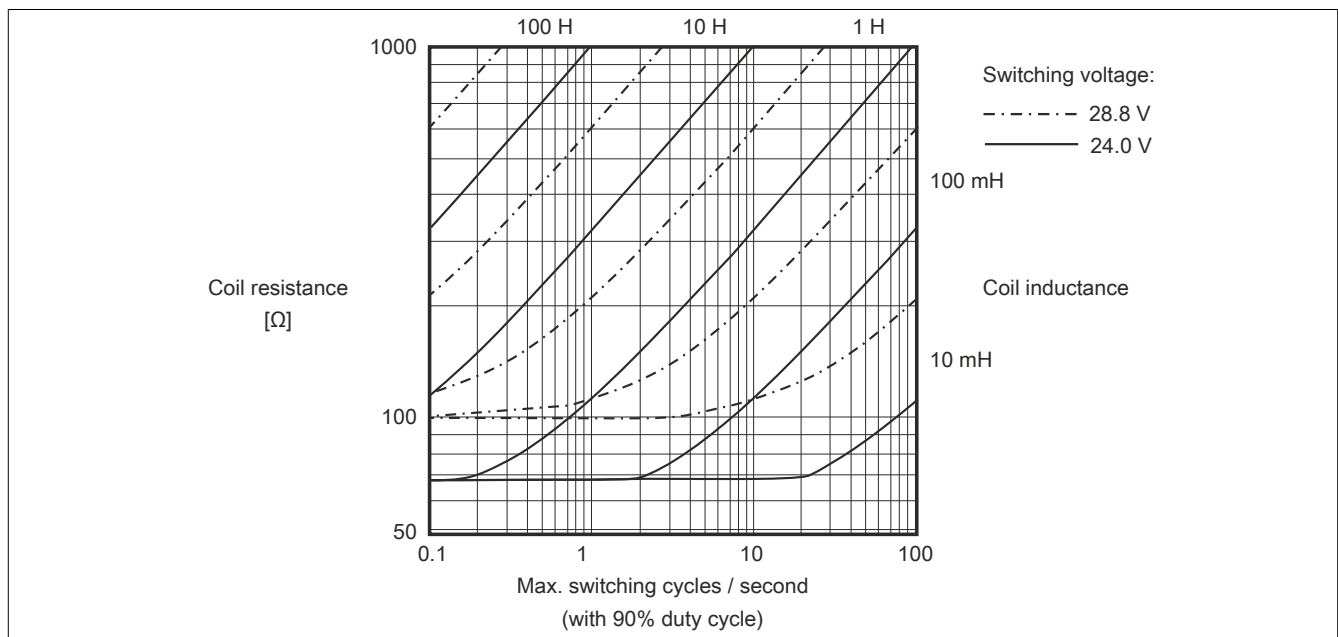

### Information:

If the maximum number of operating cycles per second is exceeded, an external inverse diode must be used.

Operating conditions outside of the area in the diagram are not permitted!

## 11 Register description

### 11.1 General data points

In addition to the registers listed in the register description, the module also has other more general data points. These registers are not specific to the module but contain general information such as serial number and hardware version.

General data points are described in section "Additional information - General data points" of the X20 system user's manual.

### 11.2 Function model 0 - Standard

Register	Fixed offset	Name	Data type	Read		Write	
				Cyclic	Acyclic	Cyclic	Acyclic
2	0	DigitalOutput	UINT			•	
		Switching state of digital outputs 1 to 8	USINT			•	
		DigitalOutput01	Bit 0				
		...	...				
3	1	DigitalOutput08	Bit 7				
		Switching state of digital outputs 9 to 12	USINT			•	
		DigitalOutput09	Bit 0				
		...	...				
30	1	DigitalOutput12	Bit 3				
		StatusInput01	UINT	•			
		Status of digital outputs 1 to 8	USINT	•			
		StatusDigitalOutput01	Bit 0				
31	2	...	...				
		StatusDigitalOutput08	Bit 7				
		Status of digital outputs 9 to 12	USINT	•			
		StatusDigitalOutput09	Bit 0				
		...	...				
		StatusDigitalOutput12	Bit 3				

Fixed modules require their data points to be in a specific order in the X2X frame. Cyclic access occurs according to a predefined offset, not based on the register address.

Acyclic access continues to be based on the register numbers.

### 11.3 Function model 254 - Bus Controller

Register	Offset <sup>1)</sup>	Name	Data type	Read		Write	
				Cyclic	Acyclic	Cyclic	Acyclic
2	0	Switching state of digital outputs 1 to 8	USINT			•	
		DigitalOutput01	Bit 0				
		...	...				
		DigitalOutput08	Bit 7				
3	1	DigitalOutput12	Bit 3				
		Switching state of digital outputs 9 to 12	USINT			•	
		DigitalOutput09	Bit 0				
		...	...				
30	-	DigitalOutput01	Bit 0				
		Status of digital outputs 1 to 8	USINT		•		
		StatusDigitalOutput01	Bit 0				
		...	...				
31	-	StatusDigitalOutput08	Bit 7				
		Status of digital outputs 9 to 12	USINT		•		
		StatusDigitalOutput09	Bit 0				
		...	...				
		StatusDigitalOutput12	Bit 3				

1) The offset specifies where the register is within the CAN object.

#### 11.3.1 Using the module on the bus controller

Function model 254 "Bus controller" is used by default only by non-configurable bus controllers. All other bus controllers can use other registers and functions depending on the fieldbus used.

For detailed information, see section "Additional information - Using I/O modules on the bus controller" of the X20 user's manual (version 3.50 or later).

#### 11.3.2 CAN I/O bus controller

The module occupies 2 digital logical slots on CAN I/O.

## 11.4 Digital outputs

The output status is transferred to the output channels with a fixed offset (<60  $\mu$ s) in relation to the network cycle (SyncOut).

### 11.4.1 Switching state of digital outputs 1 to 12

Name:

DigitalOutput

DigitalOutput01 to DigitalOutput12

The switching state of digital outputs 1 to 12 are stored in this register.

Function model 0 - Standard only:

The "Packed outputs" setting in the Automation Studio I/O configuration is used to determine whether all of these registers' bits should be set up individually as data points in the Automation Studio I/O mapping ("DigitalOutput01" through "DigitalOutput12") or whether these registers should be displayed as an individual UINT data point ("DigitalOutput").

Data type	Value	Value
UINT	0 to 4095	Packed outputs = on
USINT	See bit structure	Packed outputs = off or function model <> 0 - Standard

Bit structure:

#### Register 2, Offset 0:

Bit	Name	Value	Information
0	DigitalOutput01	0	Digital output 01 reset
		1	Digital output 01 set
...		...	
7	DigitalOutput08	0	Digital output 08 reset
		1	Digital output 08 set

#### Register 3, Offset 1:

Bit	Name	Value	Information
0	DigitalOutput09	0	Digital output 09 reset
		1	Digital output 09 set
...		...	
3	DigitalOutput12	0	Digital output 12 reset
		1	Digital output 12 set

## 11.5 Monitoring status of the digital outputs

On the module, the output states of the outputs are compared to the target states. The control of the output driver is used for the target state.

A change in the output state resets monitoring for that output. The status of each individual channel can be read. A change in the monitoring status generates an error message.

### 11.5.1 Status of digital outputs 1 to 12

Name:

StatusInput01

StatusDigitalOutput01 to StatusDigitalOutput12

The status of digital outputs 1 to 12 is mapped in this register.

Function model 0 - Standard only:

The "packed outputs" setting in the Automation Studio I/O configuration is used to determine whether all of these registers' bits should be set up individually as data points in the Automation Studio I/O mapping ("StatusDigitalOutput01" through "StatusDigitalOutput12") or whether these registers should be displayed as an individual UINT data point ("StatusDigitalOutput").

Data type	Value	Value
UINT	0 to 4095	Packed outputs = on
USINT	See bit structure	Packed outputs = off or function model <> 0 - Standard

Bit structure:

#### Register 30, (Offset 1):

Bit	Name	Value	Description
0	StatusDigitalOutput01	0	Channel 01: No error
		1	Channel 01: <ul style="list-style-type: none"> <li>Short circuit or overload</li> <li>Channel switched on and missing I/O power supply</li> <li>Channel switched off and external voltage applied on channel</li> </ul>
...	...	...	...
7	StatusDigitalOutput08	0	Channel 08: No error
		1	Channel 08: For error description, see channel 01

#### Register 31, (Offset 2):

Bit	Name	Value	Information
0	StatusDigitalOutput09	0	Channel 09: No error
		1	Channel 09: <ul style="list-style-type: none"> <li>Short circuit or overload</li> <li>Channel switched on and missing I/O power supply</li> <li>Channel switched off and external voltage applied on channel</li> </ul>
...	...	...	...
3	StatusDigitalOutput12	0	Channel 12: No error
		1	Channel 12: For error description, see channel 01

## 11.6 Minimum cycle time

The minimum cycle time defines how far the bus cycle can be reduced without communication errors occurring. It is important to note that very fast cycles reduce the idle time available for handling monitoring, diagnostics and acyclic commands.

Minimum cycle time
100 µs

## 11.7 Minimum I/O update time

The minimum I/O update time defines how far the bus cycle can be reduced while still allowing an I/O update to take place in each cycle.

Minimum I/O update time
Equal to the minimum cycle time