

The Foxboro Evo Control Network Ethernet Equipment

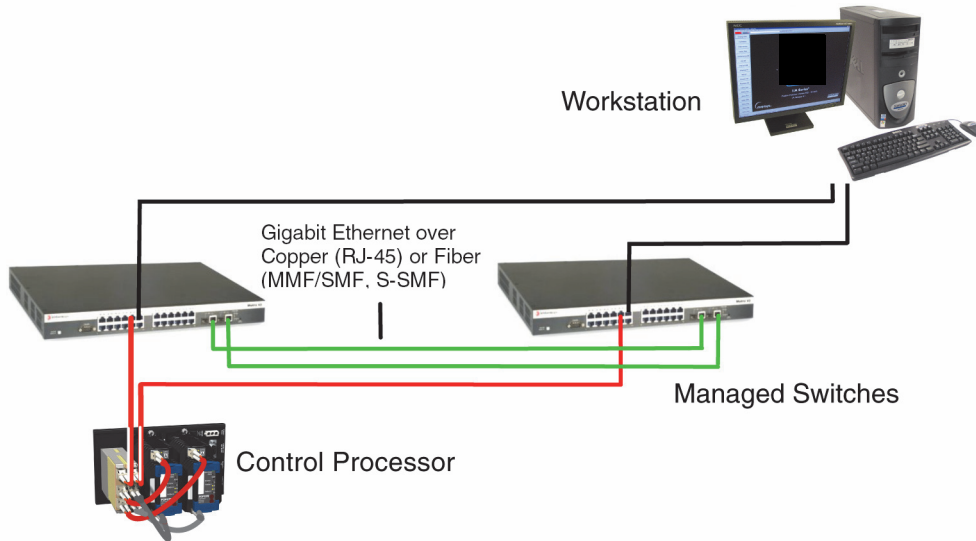

The Control Network uses Foxboro® qualified Ethernet equipment allowing you to configure your system to meet your functional, performance, and plant requirements. The switches allow you to interconnect system components (controllers, workstations, servers) effectively and to minimize the quantities and lengths of interconnectivity cabling.

OVERVIEW

The control network equipment described in this document has been tested and qualified for use with The Foxboro DCS.

The qualified Ethernet switches offered are listed in Table 1. The qualified Media Converter offered is listed in Table 2.

FEATURES

- ▶ System scalability by interconnecting Ethernet switches, each having 8-ports or more in various increments
- ▶ Modular uplinks to high-speed backbones using:
 - 1000Base-T
 - 1000Base-SX
 - 1000Base-LX
 - 1000Base-LX/LH

- 1000Base-BX
- 1000Base-TX
- 1000Base-ZX standards
- ▶ System Management software for monitoring the health of the control system and managing the equipment within the system
- ▶ Configuration tasks through a local console port (CLI), and monitoring through any SNMP/RMON based management application
- ▶ Ethernet switches and converters are European Union (EU) Low Voltage and EMC directives safety certified (“CE” logo marked on the product)

Table 1. Qualified Ethernet Switches

Switch	Page
P0973JM (A4-Series) 24-Port Copper managed switch with two RJ-45 uplink ports and two ports for Mini-GBIC modules.	Page 4
P0973JN (A4-Series) 24-Port Fiber managed switch with two RJ-45 uplink ports and two ports for Mini-GBIC modules.	Page 7
P0973JP (A4-Series) 8-Port Copper/ 8-Port Fiber managed switch with two RJ-45 uplink ports and two ports for Mini-GBIC modules.	Page 10
P0973KJ (C-Series) 26-Gigabit (SFP ^(a)) Port managed switch provides up to twenty-six 1Gb copper/fiber uplinks (ISL) or alternatively, a combination of Gigabit and 100Mb ports with up to twenty-four 100Mb end device fiber connections using the 100Base-FX Mini-GBIC (P0973JE).	Page 13
P0973LK (B-Series) 24-Gigabit (RJ-45) Port managed switch provides up to twenty-four 10/100/1000Base-TX Gigabit ports. Four SFP ^(a) ports can be populated with 1000Base-X Mini-GBIC uplink (ISL) connector modules.	Page 16
P0973LN (SSA S180 Chassis managed switch) with standalone power supply (P0973LQ), each with 48-port 1000Base-X 1 Gb SFP uplink ports and four SFP+ ports configurable as 1 Gb uplink ports or alternatively, a combination of Gigabit and 100Mb ports with up to forty-eight 100Mb end device fiber connections using the 100Base-FX Mini-GBIC (P0973JE).	Page 25
P0973KD (S4 Chassis managed switch) with up to 168 1 Gb SFP uplink ports, configured as fiber or copper uplinks or alternatively, a combination of Gigabit and 100Mb ports with up to 166 100Mb end device fiber connections using the 100Base-FX Mini-GBIC (P0973JE).	Page 29
RH102AB (X460-G2 managed switch) provides 24 modular 1000Base-X Gigabit (SFP) ports, eight (8) RJ-45 ports, four of which are combo ports (copper or SFP), with a total of 28 active ports and four (4) SFP+ ports. The 24 SFP ports can be populated with 1000Base-X (SFP) ports, 100Base-FX (P0973JE) or 100/1000Base-TX (RH102AL) MGBIC connector modules. The four (4) SFP+ ports can only be populated with 1000Base-X MGBICs.	Page 32

Table 1. Qualified Ethernet Switches (Continued)

Switch	Page
RH102AC (X460-G2 managed switch) provides 48 modular 1000Base-X (SFP) ports, four (4) SFP+ ports with a total of 52 active ports. The 48 SFP ports can be populated with 1000Base-X Gigabit, 100Base-FX (P0973JE) or 100/1000Base-TX (RH102AL) MGBIC connector modules. The four (4) SFP+ ports can only be populated with 1000Base-X MGBICs.	Page 35
RH102AD (X440-G2 managed switch) provides 24 modular 1000Base-X (SFP) ports, four (4) of which are combo ports (copper or SFP), with a total of 24 active ports. The 24 SFP ports can be populated with 1000Base-X, 100Base-FX (P0973JE) or 100/1000Base-TX (RH102AL) MGBIC connector modules.	Page 39
RH102AM (X440-G2 managed switch) provides 24 Tri-speed 10/100/1000Base-T ports with RJ-45 connectors, and four SFP 1000Base-X uplink (ISL) Gigabit (SFP1) ports (located on the back of the unit), with a total of 28 active ports. The four (SFP) ports can be populated with 1000Base-X, 100Base-FX (P0973JE) or 100/1000Base-TX (RH102AL) MGBIC connector modules.	Page 59
RH102AN (X440-G2 managed switch) provides 24 100Base-FX ports with LC connectors and four (4) 1000Base-X (SFP) ports, with a total of 28 active ports. The four (SFP) ports can be populated with 1000Base-X, or 100/1000Base-TX (RH102AL) MGBIC connector modules.	Page 46
RH102AP (X440-G2 managed switch) provides 12 Tri-speed 10/100/1000Base-T ports with RJ-45 connectors, eight (8) 100Base-FX ports with LC connectors, and four (4) (SFP) ports. The four SFP ports can be populated with 1000Base-X, or 100/1000Base-TX (RH102AL) MGBIC connector modules.	Page 50
RH102AQ (X440-G2 managed switch) provides 12 Tri-speed 10/100/1000Base-T ports with RJ-45 connectors, and four (SFP+) ports, with a total of 16 active ports. The four (SFP+) ports can be populated with 1000Base-X, or 100/1000Base-TX (RH102AL) MGBIC connector modules.	Page 54
RH102AY (X440-G2 managed switch) provides 24 Tri-speed 10/100/1000Base-T ports with RJ-45 connectors, four (4) of which are combo ports (copper or SFP) and four (4) SFP+ ports (located on the back of the unit). The four (SFP+) ports can be populated with 1000Base-X, or 100/1000Base-TX (RH102AL) MGBIC connector modules.	Page 58

(a) Small Form Factor Pluggable

Table 2. Qualified Media Converters

Media Converter	Page Reference
Media Converter 100Base-FX to 100Base-TX (P0972XH_D)	Page 72

(P0973JM) 24-PORT COPPER MANAGED SWITCH (A4-SERIES)

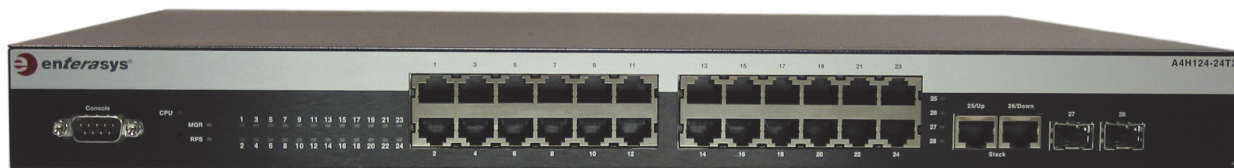

Figure 1. (A4-Series) 24-Port Copper Managed Switch (P0973JM)

OVERVIEW

The 24-Port Copper managed switch (P0973JM) provides 24 100Base-TX ports with RJ-45 connectors, two fixed 10/100/1000 Ethernet ports and two 1000Base-X uplink (ISL) Gigabit (SFP) ports.

The two 1000Base-X uplink (ISL) Gigabit (SFP) ports can be populated with the MGBIC uplink (ISL) connector modules listed in Table 3.

The switch allows high performance, full-featured layer-2 Ethernet switching in small to medium-sized network applications, as well as high performance direct end-station connectivity.

FEATURES

The 24-Port Copper managed switch features:

- ▶ 24 ports of 100Base-TX (RJ-45)
- ▶ Two fixed RJ-45 10/100/1000 ports, configurable for 100Base-Tx or 1000Base-TX for devices or 1000Base-TX for (ISL) uplink ports
- ▶ Two 1000Base-X uplink Gigabit (SFP) ports
- ▶ Full-duplex operation
- ▶ Supports VLAN configurations
- ▶ Configuration tasks through a local console port, and monitoring through any SNMP/RMON based management application.
- ▶ Port mirroring technology and diagnostics that allow local network traffic to be redirected to an external probe for detailed analysis

- ▶ When installed with the optional redundant power supply, there is no single point of failure due to power disruptions.

NOTE

Two separate branch circuits are required for redundant power.

- ▶ Shelf, desk, or 19-inch rack mounting.

OPTIONAL REDUNDANT POWER SUPPLY

Refer to “P0973JX REDUNDANT POWER SUPPLY” on page 19.

INSTALLATION GUIDELINES

NOTICE

POTENTIAL EQUIPMENT DAMAGE

These guidelines must be observed when a site is selected for this switch to avoid unsatisfactory network performance.

- ▶ To help ensure proper ventilation and help prevent overheating, leave a minimum clearance space of 5.1 cm (2.0 in) at the top, bottom, left, right, and rear of the switch.
- ▶ Ambient temperature at the air inlet for each switch must be maintained between 0° and 50°C (32° to 122°F). Temperature changes must be maintained within 10°C (18°F) per hour.

Failure to follow these instructions can result in equipment damage.

UPLINK/SWITCH INTERFACES

Table 3 lists the 24-Port Copper switch and the MGBIC modules that can be added to the switch.

The MGBIC modules are added to specific SFP ports to provide connectivity for ISL ports.

FUNCTIONAL SPECIFICATIONS

24-PORT COPPER MANAGED SWITCH (P0973JM)

Ethernet Standards Supported

- ▶ IEEE 802.1q VLAN support
- ▶ IEEE 802.1d MAC Bridging (including STP)
- ▶ IEEE 802.1p Quality of Service (QoS, Priority)
- ▶ IEEE 802.1w Rapid Spanning Tree (RSTP)
- ▶ IEEE 802.3 including:
 - Fast Ethernet: IEEE 802.3u, 100Base-T (Copper)

- Gigabit Ethernet: IEEE 802.3z, 1000Base-X (Fiber)
- Gigabit Ethernet: IEEE 802.3ab, 1000Base-T (Copper)

Power

INTERNAL

AC Input power (auto-sensing)
100 V AC to 240 V AC, 50 to 60 Hz

EXTERNAL

Supports connection for redundant power supply

MAXIMUM POWER CONSUMPTION

31 Watts

FUNCTIONAL SPECIFICATIONS (CONTINUED)

MAXIMUM HEAT DISSIPATION

105 BTUs/Hr

MAXIMUM CURRENT

0.5 A at 110 V AC, 0.47 A at 220 V AC

ENVIRONMENTAL SPECIFICATIONS

Operating Conditions

TEMPERATURE

0° to +50°C (32° to +122°F)

RELATIVE HUMIDITY

5% to 95% (noncondensing)

Storage Conditions

TEMPERATURE

-40° to +70°C (-40° to +158°F)

RELATIVE HUMIDITY

5% to 95% (noncondensing)

PHYSICAL SPECIFICATIONS

Mounting

Desk or Enclosure - 48.3 cm (19 in) equipment rack, 1U high

Dimensions - Nominal

HEIGHT

4.4 cm (1.7 in)

WIDTH

44.1 cm (17.36 in)

DEPTH

36.85 cm (14.5 in)

Weight - Approximate

2.61 kg (5.8 lb)

Cable Connectors

SWITCH PORTS

RJ-45

UPLINK PORTS

RJ-45 copper and LC fiber

Vibration

Vibration - IEC 68-2-36, IEC 68-2-6

Shock - IEC 68-2-29

REGULATORY COMPLIANCE AND CERTIFICATION

Electromagnetic Compatibility (EMC)

47 CFR Parts 2 and 15, CSA C108.8, 2004/108/EC, (EMI) (Class A) EN 55022, EN 61000-3-2, EN 61000-3-3, EN 55024, AS/NZS CISPR 22, VCCI V-3

Product Safety

UL 60950, CSA C22.2 No. 60950, 2006/95/EC, EN 60950, IEC 60950, EN 60825, 21 CFR 1040.10

Location

UL/UL-C listed as suitable for use in ordinary locations and meets ordinary safety standards for fire and shock hazards.

Contamination

Class G1 (Mild) as defined in ISA Standard S71.04

(P0973JN) 24-PORT FIBER MANAGED SWITCH (A4-SERIES)

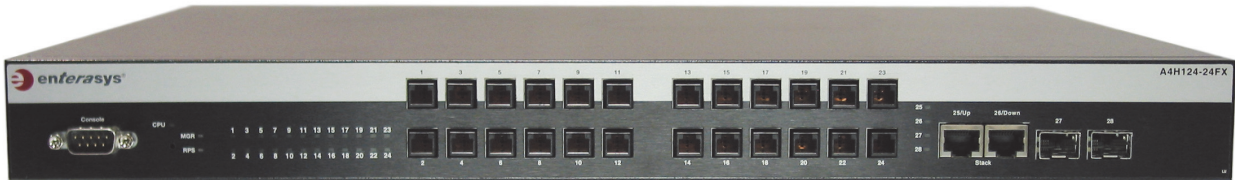

Figure 2. (A4-Series) 24-Port Fiber Managed Switch (P0973JN)

OVERVIEW

The 24-Port Fiber managed switch (P0973JN) provides 24 100Base-FX ports with MT-RJ connectors, two fixed 10/100/1000 ports and two 1000Base-X uplink (ISL) Gigabit (SFP) ports.

The two 1000Base-X uplink (ISL) Gigabit (SFP) ports can be populated with Mini-GBIC uplink (ISL) connector modules listed in Table 4.

The switch allows high-performance, full-featured layer-2 Ethernet switching in small to medium-sized network applications, as well as high-performance direct end-station connectivity.

FEATURES

The 24-Port Fiber managed switch features:

- ▶ 24 ports of 100Base-FX
- ▶ Two fixed RJ-45 10/100/1000 ports, configurable for 100Base-Tx or 1000Base-TX for devices or 1000Base-TX for (ISL) uplink ports
- ▶ Two 1000Base-X uplink Gigabit (SFP) ports
- ▶ MT-RJ connectors on switch ports
- ▶ Full-duplex operation
- ▶ Supports VLAN configurations
- ▶ Configuration tasks through a local console port, and monitoring through any SNMP/RMON based management application.
- ▶ Shelf, desk, or 19-inch rack mounting
- ▶ Port mirroring technology and diagnostics that

allow local network traffic to be redirected to an external probe for detailed analysis

- ▶ When installed with the optional redundant power supply, there is no single point of failure due to power disruptions.

NOTE

Two separate branch circuits are required for redundant power.

OPTIONAL REDUNDANT POWER SUPPLY

Refer to “P0973JX REDUNDANT POWER SUPPLY” on page 19.

INSTALLATION GUIDELINES

NOTICE

POTENTIAL EQUIPMENT DAMAGE

These guidelines must be observed when a site is selected for this switch to avoid unsatisfactory network performance.

- ▶ To help ensure proper ventilation and help prevent overheating, leave a minimum clearance space of 5.1 cm (2.0 in) at the top, bottom, left, right, and rear of the switch.
- ▶ Ambient temperature at the air inlet for each switch must be maintained between 0° and 50°C (32° to 122°F). Temperature changes must be maintained within 10°C (18°F) per hour.

Failure to follow these instructions can result in equipment damage.

UPLINK/SWITCH INTERFACES

Table 3 lists the 24-Port Fiber managed switch and the MGBIC modules that can be added to the

switch. The MGBIC modules are added to specific SFP ports to provide connectivity for ISL ports.

FUNCTIONAL SPECIFICATIONS

24-PORT FIBER MANAGED SWITCH (P0973JN)

Ethernet Standards Supported

- ▶ IEEE 802.1q VLAN support
- ▶ IEEE 802.1d MAC Bridging (including STP)
- ▶ IEEE 802.1p Quality of Service (QoS, Priority)
- ▶ IEEE 802.1w Rapid Spanning Tree (RSTP)
- ▶ IEEE 802.3 including:
 - Fast Ethernet: IEEE 802.3u, 100Base-FX (Fiber)

- Gigabit Ethernet: IEEE 802.3z, 1000Base-X (Fiber)
- Gigabit Ethernet: IEEE 802.3ab, 1000Base-T (Copper)

Power

INTERNAL

AC Input power (auto-sensing)
100 V AC to 240 V AC, 50 to 60 Hz

EXTERNAL

Supports connection for redundant power supply

MAXIMUM POWER CONSUMPTION

66 Watts

FUNCTIONAL SPECIFICATIONS (CONTINUED)

MAXIMUM HEAT DISSIPATION

224 BTUs/Hr

MAXIMUM CURRENT

0.5 A at 110 V AC, 0.47 A at 220 V AC

ENVIRONMENTAL SPECIFICATIONS

Operating Conditions

TEMPERATURE

0° to +50°C (32° to +122°F)

RELATIVE HUMIDITY

5% to 95% (noncondensing)

Storage Conditions

TEMPERATURE

-40° to +70°C (-40° to +158°F)

RELATIVE HUMIDITY

5% to 95% (noncondensing)

PHYSICAL SPECIFICATIONS

Mounting

Desk or Enclosure - 48.3 cm (19 in) equipment rack, 1U high

Dimensions

HEIGHT

4.4 cm (1.7 in)

WIDTH

44.1 cm (17.36 in)

DEPTH

36.85 cm (14.5 in)

Weight - Approximate

2.7 kg (5.95 lb)

Cable Connectors

SWITCH PORTS

MT-RJ fiber

UPLINK PORTS

RJ-45 copper and LC fiber

Vibration

Vibration - IEC 68-2-36, IEC 68-2-6

Shock - IEC 68-2-29

Drop - IEC 68-2-32

REGULATORY COMPLIANCE AND CERTIFICATION

Electromagnetic Compatibility (EMC)

I47 CFR Parts 2 and 15, CSA C108.8, 89/336/EEC, (EMI) (Class A) EN 55022, EN 61000-3-2, EN 61000-3-3, EN 55024, AS/NZS CISPR 22, VCCI V-3

Product Safety

UL 60950, CSA C22.2 No. 60950, 73/23/EEC, EN 60950, IEC 60950, EN 60825, 21 CFR 1040.10

Location

UL/UL-C listed as suitable for use in ordinary locations and meets ordinary safety standards for fire and shock hazards.

Contamination

Class G1 (Mild) as defined in ISA Standard S71.04

(P0973JP) 8-PORT COPPER / 8-PORT FIBER MANAGED SWITCH (A4-SERIES)

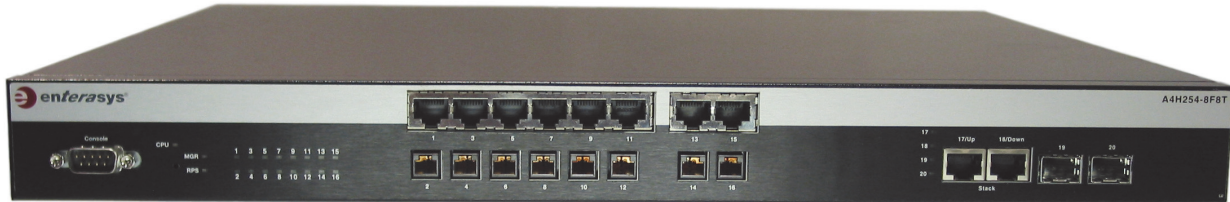

Figure 3. (A4-Series) 8-Port Copper / 8-Port Fiber Managed Switch (P0973JP)

OVERVIEW

The 8-Port Copper/8-Port Fiber managed switch (P0973JP) provides eight (8) 100Base-TX ports with RJ-45 connectors, eight (8) 100Base-FX ports with MT-RJ connectors, two fixed 10/100/1000 Ethernet ports and two 1000Base-X uplink (ISL) Gigabit (SFP) ports.

The two 1000Base-X uplink (ISL) Gigabit (SFP) ports can be populated with Mini-GBIC uplink (ISL) connector modules listed in Table 4.

The switch allows high-performance, full-featured layer-2 Ethernet switching in small to medium-sized network applications, as well as high-performance direct end-station connectivity.

FEATURES

The 8-Port Copper/8-Port Fiber managed switch features:

- ▶ 8-ports of 100Base-FX (RJ-45)
- ▶ 8-ports of 100Base-TX
- ▶ Two fixed RJ-45 10/100/1000 ports, configurable for 100Base-Tx or 1000Base-TX for devices or 1000Base-TX for (ISL) uplink ports
- ▶ Two 1000Base-X uplink Gigabit (SFP) ports
- ▶ MT-RJ connectors on switch 100Mb fiber ports
- ▶ Full-duplex operations
- ▶ Supports VLAN configurations

- ▶ Configuration tasks through a local console port, and monitoring through any SNMP/RMON based management application.
- ▶ Port mirroring technology and diagnostics that allow local network traffic to be redirected to an external probe for detailed analysis
- ▶ When installed with the optional redundant power supply, there is no single point of failure due to power disruptions.

NOTE

Two separate branch circuits are required for redundant power.

- ▶ Shelf, desk, or 19-inch rack mounting.

OPTIONAL REDUNDANT POWER SUPPLY

Refer to “P0973JX REDUNDANT POWER SUPPLY” on page 19.

INSTALLATION GUIDELINES

NOTICE

POTENTIAL EQUIPMENT DAMAGE

These guidelines must be observed when a site is selected for this switch to avoid unsatisfactory network performance.

- ▶ To help ensure proper ventilation and help prevent overheating, leave a minimum clearance space of 5.1 cm (2.0 in) at the top, bottom, left, right, and rear of the switch.
- ▶ Ambient temperature at the air inlet for each switch must be maintained between 0° and 50°C (32° to 122°F). Temperature changes must be maintained within 10°C (18°F) per hour.

Failure to follow these instructions can result in equipment damage.

UPLINK/SWITCH INTERFACES

Table 3 lists the 8-Port Copper/8-Port Fiber switch and the MGBIC modules that can be added to the

switch. The MGBIC modules are added to specific SFP ports to provide connectivity for ISL ports.

FUNCTIONAL SPECIFICATIONS

8-PORT COPPER / 8-PORT FIBER MANAGED SWITCH (P0973JP)

Ethernet Standards Supported

- ▶ IEEE 802.1q VLAN support
- ▶ IEEE 802.1d MAC Bridging (including STP)
- ▶ IEEE 802.1p Quality of Service (QoS, Priority)
- ▶ IEEE 802.1w Rapid Spanning Tree (RSTP)
- ▶ IEEE 802.3 including:
 - Fast Ethernet: IEEE 802.3u, 100Base-FX and 100Base-T (Fiber/Copper)

- Gigabit Ethernet: IEEE 802.3z, 1000Base-X (Fiber)
- Gigabit Ethernet: IEEE 802.3ab, 1000Base-T (Copper)

Power

INTERNAL

AC Input power (auto-sensing)
100 V AC to 240 V AC, 50 to 60 Hz

EXTERNAL

Supports connection for redundant power supply

MAXIMUM POWER CONSUMPTION

47 Watts

FUNCTIONAL SPECIFICATIONS (CONTINUED)

MAXIMUM HEAT DISSIPATION

160 BTUs/Hr

MAXIMUM CURRENT

0.5 A at 110 V AC, 0.47 A at 220 V AC

ENVIRONMENTAL SPECIFICATIONS

Operating Conditions

TEMPERATURE

0° to +50°C (32° to +122°F)

RELATIVE HUMIDITY

5% to 95% (noncondensing)

Storage Conditions

TEMPERATURE

-40° to +70°C (-40° to +158°F)

RELATIVE HUMIDITY

5% to 95% (noncondensing)

PHYSICAL SPECIFICATIONS

Mounting

Desk or Enclosure - 48.3 cm (19 in) equipment rack,
1U high

Dimensions

HEIGHT

4.4 cm (1.7 in)

WIDTH

44.1 cm (17.36 in)

DEPTH

36.85 cm (14.5 in)

Weight - Approximate

2.7 kg (5.95 lb)

Cable Connectors

SWITCH PORTS

RJ-45 copper and MT-RJ fiber

UPLINK PORTS

RJ-45 copper and LC fiber

Vibration

Vibration - IEC 68-2-36, IEC 68-2-6

Shock - IEC 68-2-29

Drop - IEC 68-2-32

REGULATORY COMPLIANCE AND CERTIFICATION

Electromagnetic Compatibility (EMC)

47 CFR Parts 2 and 15, CSA C108.8, 89/336/EEC,
(EMI) (Class A) EN 55022, EN 61000-3-2, EN 61000-
3-3, EN 55024, AS/NZS CISPR 22, VCCI V-3

Product Safety

UL 60950, CSA C22.2 No. 60950, 73/23/EEC, EN
60950, IEC 60950, EN 60825, 21 CFR 1040.10

Location

UL/UL-C listed as suitable for use in ordinary
locations and meets ordinary safety standards for fire
and shock hazards.

Contamination

Class G1 (Mild) as defined in ISA Standard S71.04

(P0973KJ) 26-GIGABIT (SFP) PORT MANAGED SWITCH (C-SERIES)

Figure 4. (C-Series) 26-Gigabit (SFP) Port Managed Switch (P0973KJ)

OVERVIEW

The 26-Gigabit (SFP) Port managed switch (P0973KJ) provides 24 modular 1000Base-X Gigabit (SFP) ports and two (2) SFP+ ports. All 26 ports can be populated with Mini-GBIC uplink connector modules listed in Table 4.

24 1000Base-X SFP ports can be populated with the 100Base-FX Mini-GBIC (P0973JE) module for device connectivity if the switch is running on firmware 06.61.08.0013 or greater.

The switch allows high-performance, full-featured layer-2 Ethernet switching in small to medium-sized network applications. It has been designed to be utilized as an uplink switch in the control network.

FEATURES

The 26-Gigabit (SFP⁽¹⁾) Port managed switch features:

- ▶ 24 1000Base-X Gigabit (SFP) and two SFP+ ports configurable as 1G (ISL) uplink ports or end device connectivity
- ▶ Full-duplex operation
- ▶ Configuration tasks through a local console port, and monitoring through any SNMP/RMON based management application

- ▶ Port mirroring technology and diagnostics that allow local network traffic to be redirected to an external probe for detailed analysis
- ▶ When installed with the optional redundant power supply, there is no single point of failure due to power disruptions

NOTE

Two separate branch circuits are required for redundant power.

- ▶ Shelf, desk, or 19-inch rack mounting

It delivers extensive Layer 2/3/4 packet classification and marking based on any of the following:

- ▶ MAC address
- ▶ Physical port
- ▶ IP address
- ▶ IP Protocol
- ▶ TCP/UDP port
- ▶ IP subnet
- ▶ Address Resolution Protocol (ARP) & ARP Redirect

OPTIONAL REDUNDANT POWER SUPPLY

Refer to “P0973JX REDUNDANT POWER SUPPLY” on page 19.

(1) Small Form Factor Pluggable

INSTALLATION GUIDELINES

NOTICE

POTENTIAL EQUIPMENT DAMAGE

These guidelines must be observed when a site is selected for this switch to avoid unsatisfactory network performance.

- ▶ To help ensure proper ventilation and help prevent overheating, leave a minimum clearance space of 5.1 cm (2.0 in) at the top, bottom, left, right, and rear of the switch.
- ▶ Ambient temperature at the air inlet for each switch must be maintained between 0° and 50°C (32° to 122°F). Temperature changes must be maintained within 10°C (18°F) per hour.

Failure to follow these instructions can result in equipment damage.

UPLINK/SWITCH INTERFACES

Table 3 lists the MGBIC modules that can be added to the 26-Gigabit (SFP) Port Managed Switch

(P0973KJ) switch. The MGBIC modules are added to specific SFP ports to provide connectivity for ISL or device ports.

FUNCTIONAL SPECIFICATIONS

26-GIGABIT (SFP) PORT MANAGED SWITCH (P0973KJ)

Ethernet Standards Supported

- ▶ IEEE 802.1q VLAN support
- ▶ IEEE 802.1d MAC Bridging (including STP)
- ▶ IEEE 802.1p Quality of Service (QoS, Priority)
- ▶ IEEE 802.1w Rapid Spanning Tree (RSTP)
- ▶ IEEE 802.3 including:
 - Fast Ethernet: IEEE 802.3u, 100Base-FX (Fiber)
 - Gigabit Ethernet: IEEE 802.3z, 1000Base-X (Fiber)
 - Gigabit Ethernet: IEEE 802.3ab, 1000Base-T (Copper)

Power

INTERNAL

AC Input power (auto-sensing)
100 V AC to 240 V AC, 50 to 60 Hz

EXTERNAL

Supports connection for redundant power supply

HEAT DISSIPATION

223.1 BTUs (65.4 watts)/hr

FUNCTIONAL SPECIFICATIONS (CONTINUED)

POWER CONSUMPTION

29 Watts

MAXIMUM CURRENT

1.5A

ENVIRONMENTAL SPECIFICATIONS

Operating Conditions

TEMPERATURE

0° to 50°C (32° to 122°F)

RELATIVE HUMIDITY

5% to 95% (non-condensing)

Storage Conditions

TEMPERATURE

-40° to +70°C (-40° to +158°F)

RELATIVE HUMIDITY

5% to 95% (non-condensing)

PHYSICAL SPECIFICATIONS

Mounting

Desk or Enclosure - 48.3 cm (19 in) equipment rack, 1U high

Dimensions

HEIGHT

4.4 cm (1.7 in)

WIDTH

44.1 cm (17.36 in)

DEPTH

36.85 cm (14.5 in)

Weight - Approximate

5.075 kg (11.2 lbs)

Cable Connectors

UPLINK PORTS

RJ-45 copper or LC fiber

Vibration

Vibration - IEC 68-2-36, IEC 68-2-6

Shock - IEC 68-2-29

Drop - IEC 68-2-32

REGULATORY COMPLIANCE AND CERTIFICATION

Electromagnetic Compatibility (EMC)

FCC 47 CFR Part 15 (Class A), ICES-003 (Class A), EN 55022 (Class A), EN 55024, EN 61000-3-2, EN 61000-3-3, AS/NZ CISPR-22 (Class A), VCCI V-3, CNS 13438 (BSMI), 2004/108/EC (EMC Directive)

Product Safety

UL 60950-1, FDA 21 CFR 1040.10 and 1040.11, CAN/CSA C22.2 No. 60950-1, EN 60950-1, EN 60825-1, EN 60825-2, IEC 60950-1, 2006/95/EC (Low Voltage Directive)

Environmental

2011/65/EU (RoHS Directive), EN5058, 2002/96/EC (WEEE Directive), Ministry of Information Order #39 (China RoHS)

Location

UL/UL-C listed as suitable for use in ordinary locations and meets ordinary safety standards for fire and shock hazards.

Contamination

Class G1 (Mild) as defined in ISA Standard S71.04

(P0973LK) 24-GIGABIT RJ-45 PORT MANAGED SWITCH (B-SERIES)

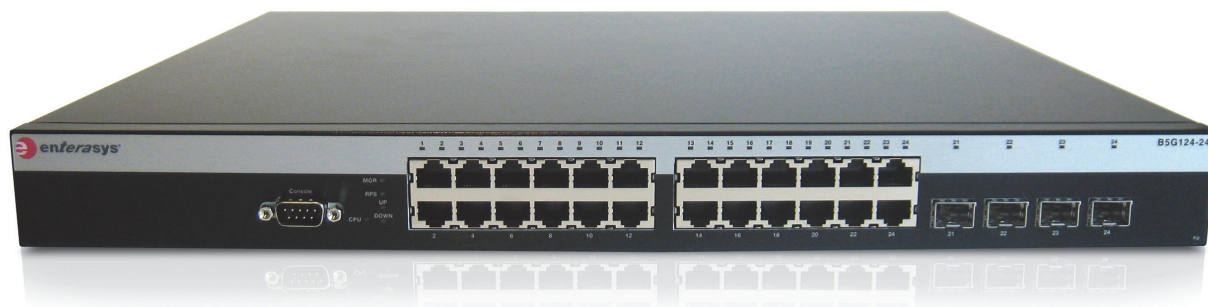

Figure 5. (B-Series) 24-Gigabit RJ-45 Port Managed Switch (P0973LK)

OVERVIEW

The 24-Gigabit (RJ-45) Port managed switches (P0973LK) provide 20 10/100/1000Base-TX Gigabit ports and four (4) combo ports 10/100/1000Base-TX or SFP ports that can be populated with 1000Base-X Mini-GBIC uplink (ISL) connector modules. If an SFP port is populated with a Mini- GBIC then the corresponding 1000Base-TX copper port cannot be used.

The switches allow high-performance, full-featured layer-2 Ethernet switching in small to medium-sized network applications.

FEATURES

The 24-Gigabit RJ-45 port managed switch features:

- ▶ 20 10/100/1000Base-TX Gigabit ports configurable as 1G uplink ports
- ▶ Four (4) optional 10/100/1000Base-TX or SFP(2) 1000Base-X Mini-GBIC ports for uplink (ISL) connector modules
- ▶ SFP(2) ports for 1000Base-X Mini-GBIC uplink (ISL) connector modules
- ▶ Full-duplex operation
- ▶ Configuration tasks through a local console port, and monitoring through any SNMP/RMON based management application

(2) Small Form Factor Pluggable

- ▶ Port mirroring technology and diagnostics that allow local network traffic to be redirected to an external probe for detailed analysis
- ▶ When installed with the optional redundant power supply, there is no single point of failure due to power disruptions.

NOTE

Two separate branch circuits are required for redundant power.

- ▶ Shelf, desk, or 19-inch rack mounting

It delivers extensive Layer 2/3/4 packet classification and marking based on any of these:

- ▶ MAC address
- ▶ Physical port
- ▶ IP address
- ▶ IP Protocol
- ▶ TCP/UDP port
- ▶ IP subnet
- ▶ Address Resolution Protocol (ARP) & ARP Redirect

OPTIONAL REDUNDANT POWER SUPPLY

Refer to “P0973JX REDUNDANT POWER SUPPLY” on page 19.

INSTALLATION GUIDELINES

NOTICE

POTENTIAL EQUIPMENT DAMAGE

These guidelines must be observed when a site is selected for this switch to avoid unsatisfactory network performance.

- ▶ To help ensure proper ventilation and help prevent overheating, leave a minimum clearance space of 5.1 cm (2.0 in) at the top, bottom, left, right, and rear of the switch.
- ▶ Ambient temperature at the air inlet for each switch must be maintained between 0° and 50°C (32° to 122°F). Temperature changes must be maintained within 10°C (18°F) per hour.

Failure to follow these instructions can result in equipment damage.

UPLINK/SWITCH INTERFACES

Table 3 lists the MGBIC modules that can be added to the 24-Gigabit RJ-45 Port Managed Switch

(P0973LK) switch. The MGBIC modules are added to specific SFP ports to provide connectivity for ISL ports.

FUNCTIONAL SPECIFICATIONS

24-GIGABIT (RJ-45) PORT MANAGED SWITCH (P0973LK)

Ethernet Standards Supported

- ▶ IEEE 802.1q VLAN support
- ▶ IEEE 802.1d MAC Bridging (including STP)
- ▶ IEEE 802.1p Quality of Service (QoS, Priority)
- ▶ IEEE 802.1w Rapid Spanning Tree (RSTP)
- ▶ IEEE 802.3 including:
 - Fast Ethernet: IEEE 802.3u, 100Base-T (Copper)

- Gigabit Ethernet: IEEE 802.3z, 1000Base-X (Fiber)
- Gigabit Ethernet: IEEE 802.3ab, 1000Base-T (Copper)

Power

INTERNAL

AC Input power (auto-sensing)
100 V AC to 240 V AC, 50 to 60 Hz

EXTERNAL

Supports connection for redundant power supply

HEAT DISSIPATION

164 BTUs/hour

FUNCTIONAL SPECIFICATIONS (CONTINUED)

POWER CONSUMPTION

48 Watts

MAXIMUM CURRENT

Up to 2A

ENVIRONMENTAL SPECIFICATIONS

Operating Conditions

TEMPERATURE

0° to 50°C (32° to 122°F)

RELATIVE HUMIDITY

5% to 95% (non-condensing)

Storage Conditions

TEMPERATURE

-40° to +70°C (-40° to +158°F)

RELATIVE HUMIDITY

5% to 95% (non-condensing)

PHYSICAL SPECIFICATIONS

Mounting

Desk or Enclosure - 48.3 cm (19 in) equipment rack, 1U high

Dimensions

HEIGHT

4.4 cm (1.7 in)

WIDTH

44.1 cm (17.36 in)

DEPTH

36.85 cm (14.5 in)

Weight - Approximate

4.92 kg (10.85 lb)

Cable Connectors

UPLINK PORTS

RJ-45 copper or LC fiber

Vibration

Vibration - IEC 68-2-36, IEC 68-2-6

Shock - IEC 68-2-29

Drop - IEC 68-2-32

REGULATORY COMPLIANCE AND CERTIFICATION

Electromagnetic Compatibility (EMC)

FCC 47 CFR Part 15 (Class A), ICES-003 (Class A), EN 55022 (Class A), EN 55024, EN 61000-3-2, EN 61000-3-3, AS/NZ CISPR-22 (Class A), VCCI V-3, CNS 13438 (BSMI), 2004/108/EC (EMC Directive)

Product Safety

UL 60950-1, FDA 21 CFR 1040.10 and 1040.11, CAN/CSA C22.2 No. 60950-1, EN 60950-1, EN 60825-1, EN 60825-2, IEC 60950-1, 2006/95/EC (Low Voltage Directive)

Environmental

2011/65/EU (RoHS Directive), 2002/96/EC (WEEE Directive), Ministry of Information Order #39 (China RoHS)

Location

UL/UL-C listed as suitable for use in ordinary locations and meets ordinary safety standards for fire and shock hazards.

Contamination

Class G1 (Mild) as defined in ISA Standard S71.04

P0973JX REDUNDANT POWER SUPPLY



Figure 6. Redundant Power Supply (P0973JX)

OVERVIEW

NOTE

Two separate branch circuits are required for redundant power.

The 150W redundant power supply (P0973JX) can supply redundant power for the P0973JM, P0973JN, P0973JP, P0973KJ, or P0973LK (SecureStack family of switches) and RH102AD, RH102AM, RH102AN, RH102AP, or RH102AY (Summit family of switched) managed switches.

NOTE

RH102AM, RH102AN, and RH102AP switch's thermal specifications exceed the thermal specification of the P0973JX RPS.

The P0973JX RPS cannot be utilized for the RH102AQ switch.

The P0973JX PRS operates in a parallel capacity with the switch's internal power supply. In case, an AC power loss is detected or there is a detected failure of an internal power supply, the redundant power supply supports the full load of the switch without affecting network operation.

The (RPS) redundant power supply (P0973JX) must be used with the (RPSC) Redundant Power Supply Chassis (P0973JV/JW). These chassis do not have AC power connections or electronics.

The P0973JW power supply chassis accommodates two RPSes (P0973JX) which can support up to two switches as listed above. The P0973JV power supply chassis accommodates up to eight RPSes (P0973JX), which can support up to eight switches.

FEATURES

The redundant power supply for the FECN qualified switches:

- ▶ Support for up to eight managed switches (one supply/switch)
- ▶ Desktop, shelf, or 19-inch rack mounting
- ▶ Up to 150W of power per supply (with up to eight supplies/chassis)



Figure 7. Redundant Power Supply Chassis (P0973JV) - Eight Slot

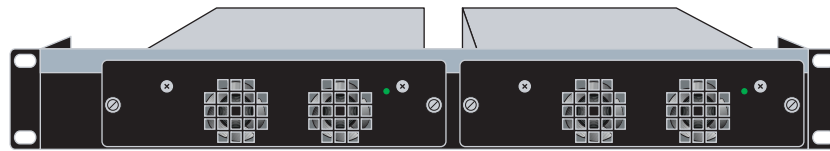

Figure 8. Redundant Power Supply Chassis (P0973JW) - Two Slot

FUNCTIONAL SPECIFICATIONS

REDUNDANT POWER SUPPLY (P0973JX)

Power

AC INPUT RANGE

85-264 V AC Hz, 47 to 63 Hz

OUTPUT

102 W or 150 W continuous

ENVIRONMENTAL SPECIFICATIONS

Operating Conditions

TEMPERATURE

5° to +50°C (41° to +122°F)

RELATIVE HUMIDITY

5% to 90% (noncondensing)

Storage Conditions

TEMPERATURE

-30° to +73°C (-22° to +164°F)

RELATIVE HUMIDITY

5% to 90% (noncondensing)

PHYSICAL SPECIFICATIONS

Mounting

Redundant power supply chassis (P0973JV for eight RPS and P0973JW for two RPS)

Dimensions

HEIGHT

19.6 cm (7.7 in)

WIDTH

5.2 cm (2.04 in)

DEPTH

25.7 cm (10.1 in)

Weight - Approximate

1.75 kg (3.85 lb)

REGULATORY COMPLIANCE AND CERTIFICATION

Electromagnetic Compatibility (EMC)

(Applies to P0973JV with eight power supplies installed and working with eight switches)
47 CFR Parts 2 and 15, CSA C108.8, 2004/108/EC, EN 55022, EN 61000-3-2, EN 61000-3-3, EN 55024; AS/NZS CISPR 22, and VCCI V-3

Product Safety

UL 60950, CSA C22.2 No. 60950, 2006/95/EC, EN 60950, and IEC 60950, EN 60825-1, EN 60825-2

Environmental

2011/65/EU (RoHS), EN 50581

Location

UL/UL-C listed as suitable for use in ordinary locations and meets ordinary safety standards for fire and shock hazards.

Contamination

Class G1 (Mild) as defined in ISA Standard S71.04

REDUNDANT POWER SUPPLY (P0973JV)

PHYSICAL SPECIFICATIONS

Mounting

Desk or Enclosure - 48.3 cm (19 in) equipment rack,
5U high

Dimensions

HEIGHT

22.26 cm (8.77 in)

WIDTH

44 cm (17.3 in)

DEPTH

26.4 cm (10.4 in)

Weight - Approximate

5.27 kg (11.6 lb)

Power Supply Slots

Eight slots for redundant power supplies (P0973JX)

REDUNDANT POWER SUPPLY CHASSIS (P0973JW)

PHYSICAL SPECIFICATIONS

Mounting

Desk or Enclosure - 48.3 cm (19 in) equipment
rack, 1U high

Dimensions

HEIGHT

5.5 cm (2.2 in)

Width

48.2 cm (19 in)

Depth

18 cm (7.0 in)

Weight - Approximate

0.95 kg (2.09 lb)

Power Supply Slots

Two slots for redundant power supplies (P0973JX)

(P0973LN) SSA CHASSIS MANAGED SWITCHES (S-SERIES)

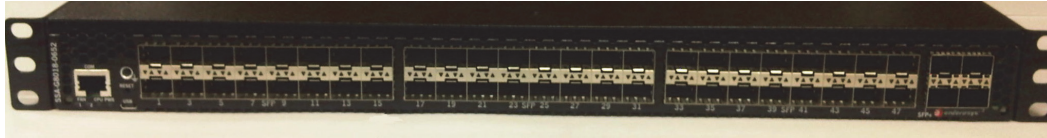

Figure 9. P0973LN SSA Managed Switch

OVERVIEW

The SSA Chassis managed switch provides 48 SFP and four (4) SFP+ 1000Base-X 1Gb uplink ports.

The switch allows high-performance, full-featured Ethernet switching in small to medium-sized network applications, as well as high-performance direct end-station connectivity.

Distributed switching architecture with redundant processors and integral load-sharing redundant power supplies help make the SSA Chassis managed switch reliable.

FEATURES

The features of the SSA Chassis managed switches (P0973LN) are:

- ▶ Up to 48 - 1000Base-X 1 Gb SFP uplink ports or 100Base-X SFP device ports
- ▶ 4 SFP+ uplink ports configured as 1G ISL uplink ports
- ▶ Configuration tasks through a local console port, and monitoring through any SNMP/RMON based management application
- ▶ Distributed switching architecture for optimum uptime
- ▶ When installed with the optional redundant power supply, there is no single point of failure due to power disruptions.

UPLINK/SWITCH INTERFACES

Table 3 lists the MGBIC modules that can be added to the SSA chassis (SFP) Port Managed Switch (P0973LN) switch. The MGBIC modules are added to specific SFP ports to provide connectivity for ISL or device ports.

POWER SUPPLY

A 450 watt power supply P0973LQ can be ordered for the P0973LN (power supplies are ordered separately). Each power supply installed requires one separately fused, 15-amp power circuit within 182 cm (6 ft) of the power supply. For redundancy, an optional second supply slot is available.

NOTE

Two separate branch circuits are required for the redundant power.

INSTALLATION GUIDELINES

NOTICE

POTENTIAL EQUIPMENT DAMAGE

These guidelines must be observed when a site is selected for the SSA Chassis managed switch. If the guidelines are not followed, unsatisfactory network performance can result.

- ▶ If installed in an enclosure other than the G50 Server enclosure, be aware that the air flow for the SSA Chassis managed switch is different from other the control network switches and this can impact the air circulation in the enclosure.
- ▶ To help ensure proper ventilation and help prevent overheating, leave a minimum clearance space of 5.1 cm (2.0 in) of clearance on the top, bottom, left, right, and rear of the unit.
- ▶ Ambient temperature at the air inlet for each switch must be maintained between 5° and 40°C (41° to 104°F). Temperature changes must be maintained within 10°C (18°F) per hour.

Failure to follow these instructions can result in equipment damage.

 **CAUTION**

POTENTIAL EQUIPMENT DAMAGE

- ▶ To install the SSA Chassis managed switch as a freestanding unit on a shelf, the shelf must be able to adequately support the static weight of the unit.
- ▶ To install the P0973LN SSA Chassis managed switch as rack mounted unit using the optional SSA rail kit RH102AA (ordered separately), help ensure that the rack used supports the unit and stabilizes after installation.

Failure to follow these instructions can result in injury.

- ▶ The SSA Chassis managed switch can be mounted in a 19" rack, such as in the G50 Server enclosure, discussed in *G50 Server Enclosure* (PSS 31H-2G50).
- ▶ The power supplies for the SSA Chassis managed switch need two three-pronged power receptacles capable of delivering the current and voltage specified below. AC outlets on

independently fused circuits are required for each power supply, and must be located less than 2 m (6 ft) from the unit. The power cord used and type of outlet is dependent on the country. In the United States, power cords with NEMA 5-15P plugs are provided with each power supply.

The SSA Chassis switch can be mounted on a desktop, or in three types of racks:

- ▶ Four-post rack
- ▶ Two-post rack (18 cm (7 in) posts)
- ▶ Two-post rack (7.6 cm (3 in) posts).

FUNCTIONAL SPECIFICATIONS

P0973LN SSA CHASSIS MANAGED SWITCH

Ethernet Standards Supported

- ▶ IEEE 802.1q VLAN support
- ▶ IEEE 802.1d MAC Bridging (including STP)
- ▶ IEEE 802.1p Quality of Service (QoS, Priority)
- ▶ IEEE 802.1w Rapid Spanning Tree (RSTP)
- ▶ IEEE 802.3 including:
 - Fast Ethernet: IEEE 802.3u, 100Base-FX (Fiber)
 - Gigabit Ethernet: IEEE 802.3z, 1000Base-X (Fiber)
 - Gigabit Ethernet: IEEE 802.3ab, 1000Base-T (Copper)

Power (P0973LN)

POWER SUPPLY PART NUMBER

P0973LQ

INTERNAL

Up to 2 AC input power supplies (auto-sensing)
100 V AC to 240 V AC, 50 to 60 Hz

EXTERNAL

N/A

HEAT DISSIPATION

BTUs - 1060 BTU/hour + 4.1 BTU/hour for every populated SFP

POWER CONSUMPTION

425 Watts

MAXIMUM CURRENT

5.3A

ENVIRONMENTAL SPECIFICATIONS

Operating Conditions

TEMPERATURE

5°C to 40°C (41°F to 104°F)

RELATIVE HUMIDITY

5% to 90% (non-condensing)

Storage Conditions

TEMPERATURE

-30°C to 73°C (-22°F to 164°F)

RELATIVE HUMIDITY

5% to 90% (non-condensing)

PHYSICAL SPECIFICATIONS

Mounting

Desk or Enclosure - 48.3 cm (19 in) equipment rack, 1U high

Dimensions

HEIGHT

4.4 cm (1.7 in)

WIDTH

44.7 cm (17.6 in)

DEPTH

59.43 cm (23.4 in)

Weight - Approximate

11.79 kg (26 lb)

Cable Connectors

UPLINK PORTS

RJ-45 copper or LC fiber

Vibration

Vibration - IEC 68-2-36, IEC 68-2-6

Shock - IEC 68-2-29

Drop - IEC 68-2-32

REGULATORY COMPLIANCE AND CERTIFICATION

Electromagnetic Compatibility (EMC)

FCC 47 CFR Part 15 (Class A), ICES-003 (Class A), EN 55022 (Class A), EN 55024, EN 61000-3-2, EN 61000-3-3, AS/NZ CISPR-22 (Class A). VCCI V-3. CNS 13438 (BSMI), 2004/108/EC (EMC Directive)

Product Safety

Safety: UL 60950-1, FDA 21 CFR 1040.10 and 1040.11, CAN/CSA C22.2, No. 60950-1, EN 60950-1, EN 60825-1, EN 60825-2, IEC 60950-1, 2006/95/EC (Low Voltage Directive)

Modules which support laser connections also meet the EN 60825 and 21 CFR 1040.10 standards.

Environmental

2011/65/EU (RoHS Directive), 2002/96/EC (WEEE Directive), Ministry of Information Order #39 (China RoHS)

Location

UL/UL-C listed as suitable for use in ordinary locations and meets ordinary safety standards for fire and shock hazards.

Contamination

Class G1 (Mild) as defined in ISA Standard S71.04

(P0973KD) S4 CHASSIS SWITCH (S-SERIES)

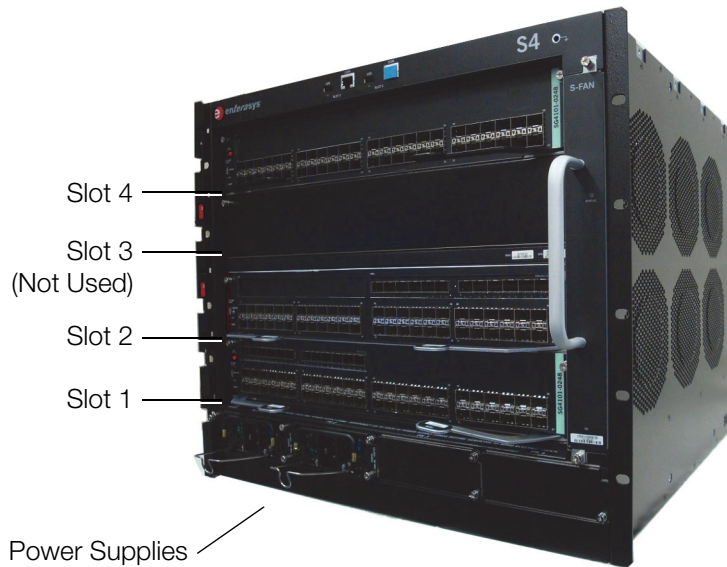

Figure 10. (S-Series) S4 Chassis Switch (P0973KD)

OVERVIEW

The S4 Chassis managed switch provides up to 168 SFP ports depending on the number of blades and modules installed.

The S4 Chassis managed switch consists of three usable slots within a 4-slot chassis with four empty power supply locations and a front mounted fan assembly. The 3-slots can be populated with Ethernet blades/modules, depending on your needs.

Slot 2 in the switch must be populated with an I/O Fabric module (P0973LP) for switch operations. The I/O Fabric module is the master blade for the switch, controlling the other slot locations. To achieve proper failover in case of a detected failure of an I/O Fabric module, Slot 3 cannot be populated.

The switches allow high performance, full-featured Ethernet switching in medium to large-sized network applications. Direct end-station connectivity is possible when using the 100Mb GBIC (P0973JE).

NOTE

S4 Chassis managed switch requires a minimum of two power supplies installed. If the P0973KE power supply is utilized then a 20-amp branch circuits is required. If the P0973LJ power supply is being utilized then a 15-amp branch circuit can be used.

FEATURES

The features of the S4 Chassis managed switch (P0973KD) are:

- ▶ Up to 168 1Gb SFP ports depending on the choice of modules
- ▶ Monitoring and configuration tasks through a local port, or SNMP-based management application
- ▶ Distributed switching architecture for optimum uptime
- ▶ When installed with the optional redundant power supplies, there is no single point of failure due to power disruptions.

NOTE

At least two separate branch circuits are required for redundant power.

UPLINK/SWITCH INTERFACES

Table 3 lists the MGBIC modules that can be added to the S4 chassis (SFP) Port Managed Switch (P0973KD) switch. The MGBIC modules are added to specific SFP ports to provide connectivity for ISL or device ports.

Link Power Budget

The maximum drive distance depends on the quality of the installed single-mode and multi-mode fiber-optic cable segment. Use the link power budget to calculate the maximum cable length of the attached segment. The link power budget must not be exceeded.

POWER SUPPLY

The S4 chassis utilizes up to four power supplies (ordered separately) that require separately fused 20-amp or 15-amp power circuits within 182 cm (6 ft) of the power supply. For power redundancy, four power supply slots are available.

INSTALLATION GUIDELINES

These guidelines must be observed when a site is selected for the S4 Chassis managed switch. If the guidelines are not followed, unsatisfactory network performance can result.

- ▶ The S4 Chassis managed switch can be mounted in a 19" rack, such as in the G50 Server Enclosure (Refer to *G50 Server Enclosure* (PSS 31H-2G50) or *K50 Server Enclosure* (PSS 31H-2KOV)).

NOTICE

POTENTIAL EQUIPMENT DAMAGE

- ▶ If installed in an enclosure other than the G50 Server enclosure, be aware that the air flow for the S4 Chassis managed switch is different from other control network switches and this can impact the air circulation in the enclosure.
- ▶ For proper cooling, there must be a minimum amount of clearance 152 mm (6 in) behind the chassis and 51 mm (2 in) of clearance on the top, bottom, left, right, and rear of the chassis.
- ▶ Ambient temperature at the air inlet for each switch must be maintained between 5° and 40°C (41° to 104°F). Temperature changes must be maintained within 10°C (18°F) per hour.

Failure to follow these instructions can result in equipment damage.

CAUTION

POTENTIAL EQUIPMENT DAMAGE AND RISK OF INJURY

- ▶ If installing the S4 Chassis managed switch as a freestanding unit on a shelf, help ensure that the shelf can support a minimum weight of approximately 24.7 kg (54.45 lb) per fully loaded chassis and the weight of the connected network cables. The weight includes the chassis, fan tray, two power supplies, and three modules.
- ▶ If installing the S4 Chassis managed switch in an equipment rack, verify that the rack can support and stabilize with the chassis installed.

Failure to follow these instructions can result in injury or equipment damage.

- ▶ Each P0973KE or P0973LJ AC power supply needs a three-pronged power receptacle capable of delivering the current and voltage specified below. An AC outlet on a separately fused circuit is required for each P0973KE/P0973LJ supply to provide power redundancy, and must be located within 1.82 cm (6 ft) from the power supply. The power cord used and type of outlet is dependent on the country. In the United States, a power cord with a NEMA 5-20P plug is provided with each P0973KE supply and a NEMA 5-15P plug is provided with each P0973LJ supply.

FUNCTIONAL SPECIFICATIONS

P0973KD S4 CHASSIS SWITCH

Ethernet Standards Supported

- ▶ IEEE 802.1q VLAN support
- ▶ IEEE 802.1d MAC Bridging (including STP)
- ▶ IEEE 802.1p Quality of Service (QoS, Priority)
- ▶ IEEE 802.1w Rapid Spanning Tree (RSTP)
- ▶ IEEE 802.3 including:
 - Fast Ethernet: IEEE 802.3u, 100Base-FX (Fiber)
 - Gigabit Ethernet: IEEE 802.3z, 1000Base-X (Fiber)
 - Gigabit Ethernet: IEEE 802.3ab, 1000Base-T (Copper)

Fault Tolerance

SWITCH MODULES

Independent, hot-swappable modules

POWER SUPPLIES

1:1 redundant integral supplies

Number of 1 Gb SFP Uplink ports (module configuration dependent)

Up to 168

FUNCTIONAL SPECIFICATIONS (CONTINUED)

Input (Voltage/Current) at Output Power

P0973KE

20A, 100-240 V AC input, (1200/1600W)

P0973LJ

15A, 100-240 V AC input, (930/1600W)

ENVIRONMENTAL SPECIFICATIONS

Operating Conditions

TEMPERATURE

5° to 40°C (41° to 104°F)

RELATIVE HUMIDITY

5% to 90% (noncondensing)

Storage Conditions

TEMPERATURE

-30° to 73°C (-22° to 164°F)

RELATIVE HUMIDITY

5% to 90% (noncondensing)

PHYSICAL SPECIFICATIONS

P0973KD S4 CHASSIS MANAGED SWITCH

Mounting

Desk or Enclosure - 48.3 cm (19 in) equipment rack, 9U high

Chassis Dimensions - Nominal

HEIGHT

40 cm (15.75 in)

WIDTH

44.7 cm (17.6 in)

DEPTH

47.32 cm (18.63 in)

Weight - Approximate

CHASSIS

24.7 kg (54.45 lb)

Cables

COPPER

1000Base-T, RJ-45

FIBER OPTIC

1000Base-SX, 1000Base-LX, 1000Base-LX/LH, 1000Base-BX, or 1000Base-ZX LC connector

MEDIA TYPE

MMF (62.5 μm), SMF (9 μm), S-SMF (9 μm) or RJ-45 CAT5e cable

REGULATORY COMPLIANCE AND CERTIFICATION

Electromagnetic Compatibility (EMC)

47 CFR Parts 2 and 15, CSA C108.8, 2004/108/EC, EN 55022, EN 61000-3-2, EN 61000-3-3, EN 55024, AS/NZS CISPR 22, VCCI V-3

Product Safety

UL 60950, CSA C22.2 No. 60950, 2006/95/EC, EN 60950, IEC 60950, EN 60825-1, EN 60825-2
Modules which support laser connections also meet the EN 60825 and 21 CFR 1040.10 standards.

Environmental

2011/65/EU (RoHS Directive)

Location

UL/UL-C listed as suitable for use in ordinary locations and meets ordinary safety standards for fire and shock hazards.

Contamination

Class G1 (Mild) as defined in ISA Standard S71.04

RH102AB 24-GIGABIT (SFP) X460-G2 MANAGED SWITCH

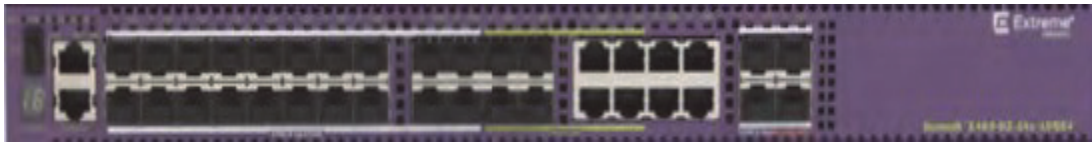

Figure 11. 24-Gigabit (SFP) X460-G2 Managed Switch (RH102AB)

OVERVIEW

RH102AB (X460-G2 managed switch) provides 24 modular 1000Base-X Gigabit (SFP) ports, eight (8) RJ-45 ports, four of which are combo ports (copper or SFP), with a total of 28 active ports and four (4) SFP+ ports. The 24 SFP ports can be populated with 1000Base-X (SFP) ports, 100Base-FX (P0973JE) or 100/1000Base-TX (RH102AL) MGBIC connector modules. The four (4) SFP+ ports can only be populated with 1000Base-X MGBICs. The four Combo ports can be used as SFP or Copper RJ-45.

The switch allows high performance, managed layer-2 Ethernet switching in small- to medium sized network applications, as well as high performance direct end-station connectivity.

FEATURES

The 24-Gigabit (SFP) X460-G2 port managed switch features:

- ▶ 24 x 100/1000Base-X (SFP) unpopulated ports – 4 ports are combo ports. (The SFP ports can be configured as 100Base-FX or 100Base-Tx with the appropriate GBIC transceiver)
- ▶ 8 x 10/100/1000Base-T (RJ-45) - 4 ports are combo ports
- ▶ 4 SFP+ (unpopulated ports), accommodates 1000Base-X GBIC only
- ▶ Full-duplex operation
- ▶ Configuration tasks through a local console port and monitoring through any SNMP/RMON based management application.

- ▶ Port mirroring technology and diagnostics that allow local network traffic to be redirected to an external probe for detailed analysis
- ▶ Compliance with industry standards, including IEEE 802.3u Fast Ethernet and 802.1w Rapid Spanning Tree Protocol (RSTP)
- ▶ Optional internal redundant power supply
- ▶ Shelf, desk, or 19-inch rack mounting

CPU/MEMORY

- ▶ 64-bit MIPS Processor, 1 GHz clock
- ▶ 1GB ECC DDR3 DRAM
- ▶ 4GB eMMC Flash
- ▶ 4MB packet buffer

UPLINK/SWITCH INTERFACES

Table 3 lists the MGBIC modules that can be added to the X460-G2 24 port (SFP) Port Managed Switch (RH102AB) switch. The MGBIC modules are added to specific SFP ports to provide connectivity for ISL or device ports.

POWER SUPPLY

The RH102AB switch power is provided by an hot swappable power supply RH102AE (ordered separately) that requires separately fused 15-amp power circuits within 182 cm (6 ft) of the power supply.

For power redundancy, a second power supply slot is available.

OPTIONAL REDUNDANT POWER SUPPLY

Refer to “RH102AE 300W AC POWER SUPPLY (X460)” on page 62.

INSTALLATION GUIDELINES

NOTICE

POTENTIAL EQUIPMENT DAMAGE

These guidelines must be observed when a site is selected for this switch. If the guidelines are not followed, unsatisfactory network performance can result.

- ▶ To help ensure proper ventilation and help prevent overheating, leave a minimum clearance space of 5.1 cm (2.0 in) at the top, bottom, left, right, and rear of the switch. Do not connect the switch to the AC power source until instructed to do so later in the installation process.
- ▶ Ambient temperature at the installation site must be maintained between 0° and 45°C (32° to 113°F). Temperature changes must be maintained within 10°C (18°F) per hour.

Failure to follow these instructions can result in equipment damage.

NOTE

The RH102AB managed switch requires a fan tray (RH102AF), ordered separately.

FUNCTIONAL SPECIFICATIONS

RH102AB 24- GIGABIT (SFP) X460-G 2 MANAGED SWITCH

Ethernet Standards Supported

- ▶ IEEE 802.1q VLAN support
- ▶ IEEE 802.1d MAC Bridging (including STP) IEEE 802.1p
- ▶ Quality of Service (QoS, Priority) IEEE 802.1w Rapid Spanning Tree (RSTP) IEEE 802.3 including:
 - Fast Ethernet: IEEE 802.3u, 100Base-T (Copper)

- Gigabit Ethernet: IEEE 802.3z, 1000Base-X (Fiber)
- Gigabit Ethernet: IEEE 802.3ab, 1000Base-T (Copper)

Power

INTERNAL

AC Input power (auto-ranging)
85 V AC to 264 V AC, 47 to 63 Hz

EXTERNAL

N/A

FUNCTIONAL SPECIFICATIONS (CONTINUED)

HEAT DISSIPATION

304 BTUs/hour

POWER CONSUMPTION

89 Watts

ENVIRONMENTAL SPECIFICATIONS

Operating Conditions

TEMPERATURE

0° to 50°C (32° to 122°F)

RELATIVE HUMIDITY

10% to 95% (non-condensing)

Storage Conditions

TEMPERATURE

-40° to +70°C (-40° to +158°F)

RELATIVE HUMIDITY

10% to 95% (non-condensing)

PHYSICAL SPECIFICATIONS

Mounting

Desk or Enclosure - 48.3 cm (19 in) equipment rack, 1U high

Dimensions

HEIGHT

4.4 cm (1.73 in)

WIDTH

44.1 cm (17.4 in)

DEPTH

43.2 cm (17.0 in)

Weight - Approximate

6.01 kg (13.2 lb)

Cable Connectors

UPLINK PORTS

RJ-45 copper or LC fiber

Vibration

Vibration - IEC 68-2-36, IEC 68-2-6

Shock - IEC 68-2-29

Drop - IEC 68-2-32

REGULATORY AND SAFETY

NORTH AMERICAN ITE

- ▶ UL 60950-1 2nd Ed., Listed Device (U.S.)
- ▶ CSA C22.2 No. 60950-1-07 2nd Ed. (Canada)
- ▶ Complies with FCC 21CFR 1040.10 (U.S. Laser Safety)
- ▶ CDRH Letter of Approval (US FDA Approval)

EUROPEAN ITE

- ▶ EN 60950-1:2006+A11+A1+A12+A2:2013
- ▶ EN 60825-1:2014
- ▶ EN 60825-2:2004+A1+A2
- ▶ TUV-R GS Mark by German Notified Body
- ▶ 2014/35/EU Low Voltage Directive

REGULATORY AND SAFETY (CONTINUED)

INTERNATIONAL ITE

- ▶ CB scheme: IEC 60950-1: 2005,2nd Ed.+A1-2009 +A2:2013, + National Differences
- ▶ AS/NZX 60950-1 (Australia /New Zealand)

Electromagnetic Compatibility

2014/30/EU EMC Directive
EN 300-386 v1.6.1 (2012-09)
CISPR32:2014, Class A
EN 55032: 2014, Class A
CISPR11:2009+A1:2010, Class A
EN 61000-3-2:2006+A2:2009
EN 61000-3-3:2013
EN 61000-6-4:2007+A1:2011
CISPR24:2010
EN 55024:2010
EN 300-386 v1.6.1 (2012-09)
EN 61000-6-2:2005

North America

FCC Part 15,Subpart B, Class A
ICES-003: 2012, Class A

Environmental

2011/65/EU RoHS Directive
EN 50581:2012

RH102AC 48-GIGABIT (SFP) X460-G2 MANAGED SWITCH



Figure 12. 48-Gigabit (SFP) X460-G2 Managed Switch (RH102AC)

OVERVIEW

RH102AC (X460-G2 managed switch) provides 48 modular 1000Base-X (SFP) ports, four (4) SFP+ ports with a total of 52 active ports. The 48 SFP ports can be populated with 1000Base-X Gigabit, 100Base-FX (P0973JE) or 100/1000Base-TX (RH102AL) MGBIC connector modules. The four (4) SFP+ ports can only be populated with 1000Base-X MGBICs

The switch allows high performance, managed layer-2 Ethernet switching in small to medium-sized network applications, as well as high performance direct end-station connectivity.

FEATURES

The 48-Gigabit (SFP) X460-G2 managed switch features:

- ▶ 48 x 100/1000Base-X (SFP) unpopulated ports – 4 ports are combo ports. (The SFP ports can be configured as 100Base-FX or 100Base-Tx with the appropriate GBIC transceiver.
- ▶ 4 SFP+ and (unpopulated ports), accommodates 1000Base-X GBIC only
- ▶ Full-duplex operation
- ▶ Configuration tasks through a local console port, or any SNMP/RMON based management application
- ▶ Port mirroring technology and diagnostics that allow local network traffic to be redirected to an external probe for detailed analysis

- ▶ Compliance with industry standards, including IEEE 802.3u Fast Ethernet and 802.1w Rapid Spanning Tree Protocol (RSTP)
- ▶ Optional internal redundant power supply
- ▶ Shelf, desk, or 19-inch rack mounting

CPU/MEMORY

- ▶ 64-bit MIPS Processor, 1 GHz clock
- ▶ 1GB ECC DDR3 DRAM
- ▶ 4GB eMMC Flash
- ▶ 4MB packet buffer

UPLINK/SWITCH INTERFACES

Table 3 lists the MGBIC modules that can be added to the X460-G2 48 port (SFP) Port Managed Switch (RH102AC) switch. The MGBIC modules are added to specific SFP ports to provide connectivity for ISL or device ports.

POWER SUPPLY

The RH102AC switch power is provided by an hot swappable power supply RH102AE (ordered separately) that requires separately fused 15-amp power circuits within 182 cm (6 ft) of the power supply.

For power redundancy, a second power supply slot is available.

OPTIONAL REDUNDANT POWER SUPPLY

Refer to “RH102AE 300W AC POWER SUPPLY (X460)” on page 62.

INSTALLATION GUIDELINES

NOTICE

POTENTIAL EQUIPMENT DAMAGE

These guidelines must be observed when a site is selected for this switch. If the guidelines are not followed, unsatisfactory network performance can result.

- ▶ To help ensure proper ventilation and help prevent overheating, leave a minimum clearance space of 5.1 cm (2.0 in) at the top, bottom, left, right, and rear of the switch. Do not connect the switch to the AC power source until instructed to do so later in the installation process.
- ▶ Ambient temperature at the installation site must be maintained between 0° and 45°C (32° to 113°F). Temperature changes must be maintained within 10°C (18°F) per hour.

Failure to follow these instructions can result in equipment damage.

NOTE

The RH102AC managed switch requires a fan tray (RH102AF), ordered separately.

FUNCTIONAL SPECIFICATIONS

RH102AC 48- GIGABIT (SFP) X460-G 2 MANAGED SWITCH

Ethernet Standards Supported

- ▶ IEEE 802.1q VLAN support
- ▶ IEEE 802.1d MAC Bridging (including STP) IEEE 802.1p
- ▶ Quality of Service (QoS, Priority) IEEE 802.1w Rapid Spanning Tree (RSTP) IEEE 802.3 including:
 - Fast Ethernet: IEEE 802.3u, 100Base-T (Copper)

- Gigabit Ethernet: IEEE 802.3z, 1000Base-X (Fiber)
- Gigabit Ethernet: IEEE 802.3ab, 1000Base-T (Copper)

Power

INTERNAL

AC Input power (auto-ranging)
85 V AC to 264 V AC, 47 to 63 Hz

EXTERNAL

N/A

HEAT DISSIPATION

345 BTUs/hour

FUNCTIONAL SPECIFICATIONS (CONTINUED)

POWER CONSUMPTION

101 Watts

MAXIMUM POWER CONSUMPTION

119 Watts

ENVIRONMENTAL SPECIFICATIONS

Operating Conditions

TEMPERATURE

0° to 50°C (32° to 122°F)

RELATIVE HUMIDITY

10% to 95% (non-condensing)

ALTITUDE

0 to 3,000 meters (9,850 feet)

Storage Conditions

TEMPERATURE

-40° to +70°C (-40° to +158°F)

RELATIVE HUMIDITY

10% to 95% (non-condensing)

PHYSICAL SPECIFICATIONS

Mounting

Desk or Enclosure - 48.3 cm (19 in) equipment rack, 1U high

Dimensions

HEIGHT

4.4 cm (1.73 in)

WIDTH

44.1 cm (17.4 in)

DEPTH

43.2 cm (17.0 in)

Weight - Approximate

6.4 kg (14.1 lb)

Cable Connectors

UPLINK PORTS

RJ-45 copper or LC fiber

Vibration

Vibration - IEC 68-2-36, IEC 68-2-6

Shock - IEC 68-2-29

Drop - IEC 68-2-32

REGULATORY AND SAFETY

NORTH AMERICAN ITE

- ▶ UL 60950-1 2nd Ed., Listed Device (U.S.)
- ▶ CSA C22.2 No. 60950-1-07 2nd Ed. (Canada)
- ▶ Complies with FCC 21CFR 1040.10 (U.S. Laser Safety)
- ▶ CDRH Letter of Approval (US FDA Approval)

- ▶ TUV-R GS Mark by German Notified Body

- ▶ 2014/35/EU Low Voltage Directive

INTERNATIONAL ITE

- ▶ CB scheme: IEC 60950-1: 2005, 2nd Ed.+A1-2009 +A2:2013, + National Differences
- ▶ AS/NZX 60950-1 (Australia /New Zealand)

EUROPEAN ITE

- ▶ EN 60950-1:2006+A11+A1+A12+A2:2013
- ▶ EN 60825-1:2014
- ▶ EN 60825-2:2004+A1+A2

REGULATORY AND SAFETY (CONTINUED)

Electromagnetic Compatibility

2014/30/EU EMC Directive
EN 300-386 v1.6.1 (2012-09)
CISPR32:2014, Class A
EN 55032: 2014, Class A
CISPR11:2009+A1:2010, Class A
EN 61000-3-2:2006+A2:2009
EN 61000-3-3:2013
EN 61000-6-4:2007+A1:2011
CISPR24:2010
EN 55024:2010
EN 300-386 v1.6.1 (2012-09)
EN 61000-6-2:2005

North America

FCC Part 15, Subpart B, Class A
ICES-003: 2012, Class A

Environmental

2011/65/EU RoHS Directive
EN 50581:2012

RH102AD 24-GIGABIT (SFP) X440-G2 MANAGED SWITCH

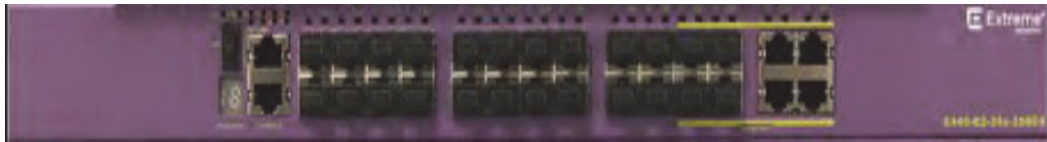

Figure 13. 24-Gigabit (SFP) X440-G2 Managed Switch (RH102AD)

OVERVIEW

RH102AD (X440-G2 managed switch) provides 24 modular 1000Base-X (SFP) ports, four (4) of which are combo ports (copper or SFP), with a total of 24 active ports. The 24 SFP ports can be populated with 1000Base-X, 100Base-FX (P0973JE) or 100/1000Base-TX (RH102AL) MGBIC connector modules.

The switch allows high performance, managed layer-2 Ethernet switching in small to medium-sized network applications, as well as high performance direct end-station connectivity.

FEATURES

The 24-Gigabit (SFP) X440-G2 managed switch features:

- ▶ 24-port 1000Base-X 1Gb SFP ports (the SFP ports can be configured as 100Base-FX or 100Base-Tx with the appropriate GBIC transceiver).
- ▶ 4-combo ports (SFP or Copper RJ-45) ports configurable as 1G uplink ports, SFP ports accommodate 1000Base-X GBICs only.
- ▶ Full-duplex operation
- ▶ Configuration tasks through a local console port and monitoring through any SNMP/RMON based management application
- ▶ Port mirroring technology and diagnostics that allow local network traffic to be redirected to an external probe for detailed analysis

- ▶ Compliance with industry standards, including IEEE 802.3u Fast Ethernet and 802.1w Rapid Spanning Tree Protocol (RSTP)
- ▶ Optional external redundant power supply
- ▶ Shelf, desk, or 19-inch rack mounting

All X440-G2 switches ship with fixed fans and power supplies.

CPU/MEMORY

- ▶ 64-bit MIPS Processor, 1 GHz clock, single core
- ▶ 1GB ECC DDR3 DRAM
- ▶ 4GB eMMC Flash
- ▶ 1.5MB packet buffer

UPLINK/SWITCH INTERFACES

Table 3 lists the MGBIC modules that can be added to the X440-G2 24 port (SFP) Port Managed Switch (RH102AD) switch. The MGBIC modules are added to specific SFP ports to provide connectivity for ISL or device ports.

POWER SUPPLY

The RH102AD switch power is provided by an internal power supply that requires separately fused 15-amp power circuits within 182 cm (6 ft) of the power supply.

OPTIONAL REDUNDANT POWER SUPPLY

Refer to “RH102AX (REDUNDANT POWER SUPPLY)” on page 65.

INSTALLATION GUIDELINES

NOTICE

POTENTIAL EQUIPMENT DAMAGE

These guidelines must be observed when a site is selected for this switch. If the guidelines are not followed, unsatisfactory network performance can result.

- ▶ To help ensure proper ventilation and help prevent overheating, leave a minimum clearance space of 5.1 cm (2.0 in) at the top, bottom, left, right, and rear of the switch. Do not connect the switch to the AC power source until instructed to do so later in the installation process.
- ▶ Ambient temperature at the installation site must be maintained between 0° and 50°C (32° to 122°F). Temperature changes must be maintained within 10°C (18°F) per hour.

Failure to follow these instructions can result in equipment damage.

FUNCTIONAL SPECIFICATIONS

RH102AD 24- GIGABIT (SFP) X440-G 2 MANAGED SWITCH

Ethernet Standards Supported

- ▶ IEEE 802.1q VLAN support
- ▶ IEEE 802.1d MAC Bridging (including STP) IEEE 802.1p
- ▶ Quality of Service (QoS, Priority) IEEE 802.1w
Rapid Spanning Tree (RSTP) IEEE 802.3
including:
 - Fast Ethernet: IEEE 802.3u, 100Base-T (Copper)
 - Gigabit Ethernet: IEEE 802.3z, 1000Base-X (Fiber)
 - Gigabit Ethernet: IEEE 802.3ab, 1000Base-T (Copper)

Power

INTERNAL

AC Input power (auto-ranging)
100 V AC to 240 V AC, 50 to 60 Hz +/- 5%

EXTERNAL

Supports connection for redundant power supply

HEAT DISSIPATION

172 BTUs/hour

POWER CONSUMPTION

26 Watts

MAXIMUM POWER CONSUMPTION

51 Watts

ENVIRONMENTAL SPECIFICATIONS

Operating Conditions

TEMPERATURE

0° to 50°C (32° to 122°F)

RELATIVE HUMIDITY

10% to 95% (non-condensing)

ALTITUDE

0 to 3,000 meters (9,850 feet)

Storage Conditions

TEMPERATURE

-40° to +70°C (-40° to +158°F)

RELATIVE HUMIDITY

10% to 95% (non-condensing)

PHYSICAL SPECIFICATIONS

Mounting

Desk or Enclosure - 48.3 cm (19 in) equipment rack, 1U high

Dimensions

HEIGHT

4.4 cm (1.73 in)

WIDTH

44.1 cm (17.4 in)

DEPTH

25.4 cm (10.1 in)

Weight - Approximate

3.73 kg (8.22 lb)

Cable Connectors

UPLINK PORTS

RJ-45 copper or LC fiber

Vibration

Vibration - IEC 68-2-36, IEC 68-2-6

Shock - IEC 68-2-29

Drop - IEC 68-2-32

REGULATORY AND SAFETY

NORTH AMERICAN ITE

- ▶ UL 60950-1 2nd Ed., Listed Device (U.S.)
- ▶ CSA C22.2 No. 60950-1-07 2nd Ed. (Canada)
- ▶ Complies with FCC 21CFR 1040.10 (U.S. Laser Safety)
- ▶ CDRH Letter of Approval (US FDA Approval)

EUROPEAN ITE

- ▶ EN 60950-1:2006+A11+A1+A12+A2:2013
- ▶ EN 60825-1:2014
- ▶ EN 60825-2:2004+A1+A2
- ▶ TUV-R GS Mark by German Notified Body
- ▶ 2014/35/EU Low Voltage Directive

INTERNATIONAL ITE

- ▶ CB scheme: IEC 60950-1: 2005, 2nd Ed. +A1-2009 +A2:2013, + National Differences
- ▶ AS/NZX 60950-1 (Australia /New Zealand)

Electromagnetic Compatibility

2014/30/EU EMC Directive
EN 300-386 v1.6.1 (2012-09)
CISPR32:2014, Class A
EN 55032: 2014, Class A
CISPR11:2009+A1:2010, Class A
CISPR24:2010
EN 55024:2010
EN 300-386 v1.6.1 (2012-09)
EN 61000-6-2:2005

REGULATORY AND SAFETY (CONTINUED)

North America

FCC Part 15, Subpart B, Class A
ICES-003: 2012, Class A

Environmental

2011/65/EU RoHS Directive
EN 50581:2012

RH102AM 24-PORT COPPER X440-G2 MANAGED SWITCH

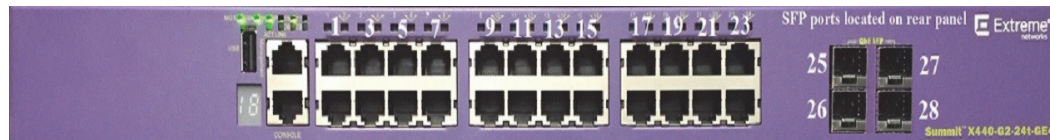

Figure 14. 24-Port Copper X440-G2 Managed Switch (RH102AM)

OVERVIEW

RH102AM (X440-G2 managed switch) provides 24 Tri-speed 10/100/1000Base-T ports with RJ-45 connectors, and four SFP 1000Base-X uplink (ISL) Gigabit ports (located on the back of the unit), with a total of 28 active ports. The four (SFP) ports can be populated with 1000Base-X, 100Base-FX (P0973JE) or 100/1000Base-TX (RH102AL) MGBIC connector modules.

The switch allows high performance, managed layer-2 Ethernet switching in small to medium sized network applications, as well as high performance direct end-station connectivity.

FEATURES

The 24-Port Copper X440-G2 managed switch features:

- ▶ 24-ports of Tri-speed 10/100/1000Base-T
- ▶ Four 1000Base-X uplink Gigabit (SFP) ports (the SFP ports are located on the back of the unit)
- ▶ RJ-45 Category 5 connectors on switch copper ports
- ▶ Full-duplex operation
- ▶ Configuration tasks through a local console port and monitoring through any SNMP/RMON based management application
- ▶ Port mirroring technology and diagnostics that allow local network traffic to be redirected to an external probe for detailed analysis
- ▶ Compliance with industry standards, including

IEEE 802.3u Fast Ethernet and 802.1w Rapid Spanning Tree Protocol (RSTP)

- ▶ Optional external redundant power supply
- ▶ Shelf, desk, or 19-inch rack mounting.

All X440-G2 switches ship with fixed fans and power supplies.

CPU/MEMORY

- ▶ 64-bit MIPS Processor, 1 GHz clock, single core
- ▶ 1GB ECC DDR3 DRAM
- ▶ 4GB eMMC Flash
- ▶ 1.5MB packet buffer

UPLINK/SWITCH INTERFACES

Table 3 lists the MGBIC modules that can be added to the X440-G2 24 port copper Port Managed Switch (RH102AM) switch. The MGBIC modules are added to specific SFP ports to provide connectivity for ISL ports.

POWER SUPPLY

The RH102AM switch power is provided by an internal power supply that requires separately fused 15-amp power circuits within 182 cm (6 ft) of the power supply.

OPTIONAL REDUNDANT POWER SUPPLY

Refer to “RH102AX (REDUNDANT POWER SUPPLY)” on page 65.

INSTALLATION GUIDELINES

NOTICE

POTENTIAL EQUIPMENT DAMAGE

These guidelines must be observed when a site is selected for this switch. If the guidelines are not followed, unsatisfactory network performance can result.

- ▶ To help ensure proper ventilation and help prevent overheating, leave a minimum clearance space of 5.1 cm (2.0 in) at the top, bottom, left, right, and rear of the switch. Do not connect the switch to the AC power source until instructed to do so later in the installation process.
- ▶ Ambient temperature at the installation site must be maintained between 0° and 60°C (32° to 140°F). Temperature changes must be maintained within 10°C (18°F) per hour.

Failure to follow these instructions can result in equipment damage.

FUNCTIONAL SPECIFICATIONS

RH102AM 24- PORT COPPER X440-G 2 MANAGED SWITCH

Ethernet Standards Supported

- ▶ IEEE 802.1q VLAN support
- ▶ IEEE 802.1d MAC Bridging (including STP) IEEE 802.1p
- ▶ Quality of Service (QoS, Priority) IEEE 802.1w
Rapid Spanning Tree (RSTP) IEEE 802.3
including:
 - Fast Ethernet: IEEE 802.3u, 100Base-T (Copper)
 - Gigabit Ethernet: IEEE 802.3z, 1000Base-X (Fiber)
 - Gigabit Ethernet: IEEE 802.3ab, 1000Base-T (Copper)

Power

INTERNAL

AC Input power (auto-ranging)
100 V AC to 240 V AC, 50 to 60 Hz +/- 5%

EXTERNAL

Supports connection for redundant power supply

HEAT DISSIPATION

130 BTUs/hour

POWER CONSUMPTION

22 Watts

MAXIMUM POWER CONSUMPTION

38 Watts

ENVIRONMENTAL SPECIFICATIONS

Operating Conditions

TEMPERATURE

0° to 60°C (32° to 140°F)

RELATIVE HUMIDITY

10% to 95% (non-condensing)

ALTITUDE

0 to 3,000 meters (9,850 feet)

Storage Conditions

TEMPERATURE

-40° to +70°C (-40° to +158°F)

RELATIVE HUMIDITY

10% to 95% (non-condensing)

PHYSICAL SPECIFICATIONS

Mounting

Desk or Enclosure - 48.3 cm (19 in) equipment rack, 1U high

Dimensions

HEIGHT

4.4 cm (1.73 in)

WIDTH

44.1 cm (17.4 in)

DEPTH

25.4 cm (10.1 in)

Weight - Approximate

3.62 kg (7.98 lb)

Cable Connectors

UPLINK PORTS

RJ-45 copper or LC fiber

Vibration

Vibration - IEC 68-2-36, IEC 68-2-6

Shock - IEC 68-2-29

Drop - IEC 68-2-32

REGULATORY AND SAFETY

NORTH AMERICAN ITE

- ▶ UL 60950-1 2nd Ed., Listed Device (U.S.)
- ▶ CSA C22.2 No. 60950-1-07 2nd Ed. (Canada)
- ▶ Complies with FCC 21CFR 1040.10 (U.S. Laser Safety)
- ▶ CDRH Letter of Approval (US FDA Approval)

EUROPEAN ITE

- ▶ EN 60950-1:2006+A11+A1+A12+A2:2013
- ▶ EN 60825-1:2014
- ▶ EN 60825-2:2004+A1+A2
- ▶ TUV-R GS Mark by German Notified Body
- ▶ 2014/35/EU Low Voltage Directive

INTERNATIONAL ITE

- ▶ CB scheme: IEC 60950-1: 2005, 2nd

Ed.+A1-2009 +A2:2013, + National Differences

- ▶ AS/NZX 60950-1 (Australia /New Zealand)

Electromagnetic Compatibility

2014/30/EU EMC Directive

EN 300-386 v1.6.1 (2012-09)

CISPR32:2014, Class A

EN 55032: 2014, Class A

CISPR11:2009+A1:2010, Class A

CISPR24:2010

EN 55024:2010

EN 300-386 v1.6.1 (2012-09)

EN 61000-6-2:2005

North America

FCC Part 15, Subpart B, Class A

ICES-003: 2012, Class A

Environmental

2011/65/EU RoHS Directive

EN 50581:2012

RH102AN 24-PORT FIBER X440-G2 MANAGED SWITCH

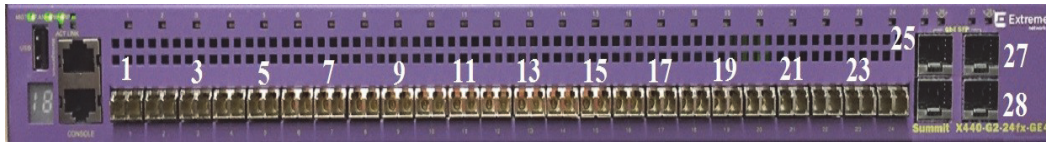

Figure 15. 24-Port Fiber X440-G2 Managed Switch (RH102AN)

OVERVIEW

RH102AN (X440-G2 managed switch) provides 24 100Base-FX ports with LC connectors and four (4) 1000Base-X (SFP) ports, with a total of 28 active ports. The four (SFP) ports can be populated with 1000Base-X, or 100/1000Base-TX (RH102AL) MGBIC connector modules

The switch allows high-performance, managed layer-2 Ethernet switching in small to medium sized network applications, as well as high performance direct end-station connectivity.

FEATURES

The 24-Port Fiber X440-G2 managed switch features:

- ▶ 24-ports of 100Base-FX LC MMF
- ▶ Four 1000Base-X uplink Gigabit (SFP) ports
- ▶ LC connectors on switch ports
- ▶ Full-duplex operation
- ▶ Configuration tasks through a local console port and monitoring through any SNMP/RMON based management application
- ▶ Port mirroring technology and diagnostics that allow local network traffic to be redirected to an external probe for detailed analysis
- ▶ Compliance with industry standards, including IEEE 802.3u Fast Ethernet and 802.1w Rapid Spanning Tree Protocol (RSTP)
- ▶ Optional external redundant power supply

- ▶ Shelf, desk, or 19-inch rack mounting

All X440-G2 switches ship with fixed fans and power supplies.

CPU/MEMORY

- ▶ 64-bit MIPS Processor, 1 GHz clock, single core
- ▶ 1GB ECC DDR3 DRAM
- ▶ 4GB eMMC Flash
- ▶ 1.5MB packet buffer

UPLINK/SWITCH INTERFACES

Table 3 lists the MGBIC modules that can be added to the X440-G2 24 port Fiber Port Managed Switch (RH102AN) switch. The MGBIC modules are added to specific SFP ports to provide connectivity for ISL ports.

POWER SUPPLY

The RH102AN switch power is provided by an internal power supply that requires separately fused 15-amp power circuits within 182 cm (6 ft) of the power supply.

OPTIONAL REDUNDANT POWER SUPPLY

Refer to “RH102AX (REDUNDANT POWER SUPPLY)” on page 65.

INSTALLATION GUIDELINES

NOTICE

POTENTIAL EQUIPMENT DAMAGE

These guidelines must be observed when a site is selected for this switch. If the guidelines are not followed, unsatisfactory network performance can result.

- ▶ To help ensure proper ventilation and help prevent overheating, leave a minimum clearance space of 5.1 cm (2.0 in) at the top, bottom, left, right, and rear of the switch. Do not connect the switch to the AC power source until instructed to do so later in the installation process.
- ▶ Ambient temperature at the installation site must be maintained between 0° and 60°C (32° to 140°F). Temperature changes must be maintained within 10°C (18°F) per hour.

Failure to follow these instructions can result in equipment damage.

FUNCTIONAL SPECIFICATIONS

RH102AN 24- PORT FIBER X440-G 2 MANAGED SWITCH

Ethernet Standards Supported

- ▶ IEEE 802.1q VLAN support
- ▶ IEEE 802.1d MAC Bridging (including STP) IEEE 802.1p
- ▶ Quality of Service (QoS, Priority) IEEE 802.1w
Rapid Spanning Tree (RSTP) IEEE 802.3
including:
 - Fast Ethernet: IEEE 802.3u, 100Base-T (Copper)
 - Gigabit Ethernet: IEEE 802.3z, 1000Base-X (Fiber)
 - Gigabit Ethernet: IEEE 802.3ab, 1000Base-T (Copper)

Power

INTERNAL

AC Input power (auto-ranging)
100 V AC to 240 V AC, 50 to 60 Hz +/- 5%

EXTERNAL

Supports connection for redundant power supply

HEAT DISSIPATION

223 BTUs/hour

POWER CONSUMPTION

166 Watts

MAXIMUM POWER CONSUMPTION

223 Watts

ENVIRONMENTAL SPECIFICATIONS

Operating Conditions

TEMPERATURE

0° to 60°C (32° to 140°F)

RELATIVE HUMIDITY

10% to 95% (non-condensing)

ALTITUDE

0 to 3,000 meters (9,850 feet)

Storage Conditions

TEMPERATURE

-40° to +70°C (-40° to +158°F)

RELATIVE HUMIDITY

10% to 95% (non-condensing)

PHYSICAL SPECIFICATIONS

Mounting

Desk or Enclosure - 48.3 cm (19 in) equipment rack, 1U high

Dimensions

HEIGHT

4.4 cm (1.73 in)

WIDTH

44.1 cm (17.4 in)

DEPTH

25.4 cm (10.1 in)

Weight - Approximate

3.93 kg (8.66 lb)

Cable Connectors

UPLINK PORTS

RJ-45 copper or LC fiber

Vibration

Vibration - IEC 68-2-36, IEC 68-2-6

Shock - IEC 68-2-29

Drop - IEC 68-2-32

REGULATORY AND SAFETY

NORTH AMERICAN ITE

- ▶ UL 60950-1 2nd Ed., Listed Device (U.S.)
- ▶ CSA C22.2 No. 60950-1-07 2nd Ed. (Canada)
- ▶ Complies with FCC 21CFR 1040.10 (U.S. Laser Safety)
- ▶ CDRH Letter of Approval (US FDA Approval)

EUROPEAN ITE

- ▶ EN 60950-1:2006+A11+A1+A12+A2:2013
- ▶ EN 60825-1:2014
- ▶ EN 60825-2:2004+A1+A2
- ▶ TUV-R GS Mark by German Notified Body
- ▶ 2014/35/EU Low Voltage Directive

INTERNATIONAL ITE

- ▶ CB scheme: IEC 60950-1: 2005, 2nd Ed.+A1-2009 +A2:2013, + National Differences
- ▶ AS/NZX 60950-1 (Australia /New Zealand)

Electromagnetic Compatibility

2014/30/EU EMC Directive
EN 300-386 v1.6.1 (2012-09)
CISPR32:2014, Class A
EN 55032: 2014, Class A
CISPR11:2009+A1:2010, Class A
CISPR24:2010
EN 55024:2010
EN 300-386 v1.6.1 (2012-09)
EN 61000-6-2:2005

North America

FCC Part 15, Subpart B, Class A
ICES-003: 2012, Class A

REGULATORY AND SAFETY (CONTINUED)

Environmental

2011/65/EU RoHS Directive
EN 50581:2012

RH102AP 12-PORT COPPER / 8-PORT FIBER X440-G2 MANAGED SWITCH

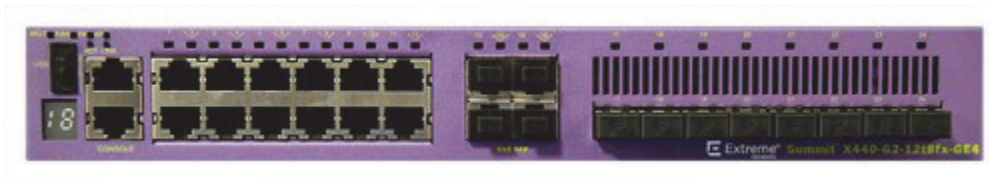

Figure 16. 12-Port Copper / 8-Port Fiber X440-G2 Managed Switch (RH102AP)

OVERVIEW

RH102AP (X440-G2 managed switch) provides 12 Tri-speed 10/100/1000Base-T ports with RJ-45 connectors, eight (8) 100Base-FX ports with LC connectors, and four (4) (SFP) ports. The four SFP ports can be populated with 1000Base-X, or 100/1000Base-TX (RH102AL) MGBIC connector modules.

The switch allows high performance, managed layer-2 Ethernet switching in small to medium-sized network applications, as well as high performance direct end-station connectivity.

FEATURES

The 12-Port Copper/8-Port Fiber X440-G2 managed switch features:

- ▶ 8-ports of 100Base-FX
- ▶ 12-ports of Tri-speed 10/100/1000Base-T
- ▶ Four 1000Base-X uplink Gigabit (SFP) ports
- ▶ RJ-45 Category 5 connectors on switch copper ports
- ▶ LC connectors on switch fiber ports
- ▶ Full-duplex operations
- ▶ Configuration tasks through a local console port and monitoring through any SNMP/RMON based management application.
- ▶ Port mirroring technology and diagnostics that allow local network traffic to be redirected to an

external probe for detailed analysis

- ▶ Compliance with industry standards, including IEEE 802.3u Fast Ethernet and 802.1w Rapid Spanning Tree Protocol (RSTP)
- ▶ Optional external redundant power supply
- ▶ Shelf, desk, or 19-inch rack mounting

All X440-G2 switches ship with fixed fans and power supplies.

CPU/MEMORY

- ▶ 64-bit MIPS Processor, 1 GHz clock, single core
- ▶ 1GB ECC DDR3 DRAM
- ▶ 4GB eMMC Flash
- ▶ 1.5MB packet buffer

UPLINK/SWITCH INTERFACES

Table 3 lists the MGBIC modules that can be added to the X440-G2, 12 copper and 8 fiber Port Managed Switch (RH102AP) switch. The MGBIC modules are added to specific SFP ports to provide connectivity for ISL ports.

POWER SUPPLY

The RH102AP switch power is provided by an internal power supply that requires separately fused 15-amp power circuits within 182 cm (6 ft) of the power supply.

OPTIONAL REDUNDANT POWER SUPPLY

Refer to “RH102AX (REDUNDANT POWER SUPPLY)” on page 65.

INSTALLATION GUIDELINES

NOTICE

POTENTIAL EQUIPMENT DAMAGE

These guidelines must be observed when a site is selected for this switch. If the guidelines are not followed, unsatisfactory network performance can result.

- ▶ To help ensure proper ventilation and help prevent overheating, leave a minimum clearance space of 5.1 cm (2.0 in) at the top, bottom, left, right, and rear of the switch. Do not connect the switch to the AC power source until instructed to do so later in the installation process.
- ▶ Ambient temperature at the installation site must be maintained between 0° and 60°C (32° to 140°F). Temperature changes must be maintained within 10°C (18°F) per hour.

Failure to follow these instructions can result in equipment damage.

FUNCTIONAL SPECIFICATIONS

RH102AP 12-PORT COPPER / 8-PORT FIBER X440-G2 MANAGED SWITCH

Ethernet Standards Supported

- ▶ IEEE 802.1q VLAN support
- ▶ IEEE 802.1d MAC Bridging (including STP) IEEE 802.1p
- ▶ Quality of Service (QoS, Priority) IEEE 802.1w Rapid Spanning Tree (RSTP) IEEE 802.3 including:
 - Fast Ethernet: IEEE 802.3u, 100Base-T (Copper)
 - Gigabit Ethernet: IEEE 802.3z, 1000Base-X (Fiber)
 - Gigabit Ethernet: IEEE 802.3ab, 1000Base-T (Copper)

Power

INTERNAL

AC Input power (auto-ranging)
100 V AC to 240 V AC, 50 to 60 Hz +/- 5%

EXTERNAL

Supports connection for redundant power supply

HEAT DISSIPATION

159 BTUs/hour

FUNCTIONAL SPECIFICATIONS (CONTINUED)

POWER CONSUMPTION

32 Watts

MAXIMUM POWER CONSUMPTION

47 Watts

ENVIRONMENTAL SPECIFICATIONS

Operating Conditions

TEMPERATURE

0° to 60°C (32° to 140°F)

RELATIVE HUMIDITY

10% to 95% (non-condensing)

ALTITUDE

0 to 3,000 meters (9,850 feet)

Storage Conditions

TEMPERATURE

-40° to +70°C (-40° to +158°F)

RELATIVE HUMIDITY

10% to 95% (non-condensing)

PHYSICAL SPECIFICATIONS

Mounting

Desk or Enclosure - 48.3 cm (19 in) equipment rack, 1U high

Dimensions

HEIGHT

4.4 cm (1.73 in)

WIDTH

30.5 cm (12.01 in)

DEPTH

26.1 cm (10.28 in)

Weight - Approximate

2.95 kg (6.5 lb)

Cable Connectors

UPLINK PORTS

RJ-45 copper or LC fiber

Vibration

Vibration - IEC 68-2-36, IEC 68-2-6

Shock - IEC 68-2-29

Drop - IEC 68-2-32

REGULATORY AND SAFETY

NORTH AMERICAN ITE

- ▶ UL 60950-1 2nd Ed., Listed Device (U.S.)
- ▶ CSA C22.2 No. 60950-1-07 2nd Ed. (Canada)
- ▶ Complies with FCC 21CFR 1040.10 (U.S. Laser Safety)
- ▶ CDRH Letter of Approval (US FDA Approval)

EUROPEAN ITE

- ▶ EN 60950-1:2006+A11+A1+A12+A2:2013
- ▶ EN 60825-1:2014
- ▶ EN 60825-2:2004+A1+A2
- ▶ TUV-R GS Mark by German Notified Body
- ▶ 2014/35/EU Low Voltage Directive

REGULATORY AND SAFETY (CONTINUED)

INTERNATIONAL ITE

- ▶ CB scheme: IEC 60950-1: 2005,2nd Ed.+A1-2009 +A2:2013, + National Differences
- ▶ AS/NZX 60950-1 (Australia /New Zealand)

Electromagnetic Compatibility

2014/30/EU EMC Directive
EN 300-386 v1.6.1 (2012-09)
CISPR32:2014, Class A
EN 55032: 2014, Class A
CISPR11:2009+A1:2010, Class A
CISPR24:2010
EN 55024:2010
EN 300-386 v1.6.1 (2012-09)
EN 61000-6-2:2005

North America

FCC Part 15,Subpart B, Class A
ICES-003: 2012, Class A

Environmental

2011/65/EU RoHS Directive
EN 50581:2012

RH102AQ 12-PORT COPPER X440-G2 MANAGED SWITCH



Figure 17. 12-Port Copper X440-G2 Managed Switch (RH102AQ)

OVERVIEW

RH102AQ provides 12 Tri-speed 10/100/1000Base-T ports with RJ-45 connectors, and four (SFP+) ports, with a total of 16 active ports. The four (SFP+) ports can be populated with 1000Base-X, or 100/1000Base-TX (RH102AL) MGBIC connector modules.

The switch allows high performance, managed layer-2 Ethernet switching in small to medium-sized network applications, as well as high performance direct end-station connectivity.

FEATURES

The 12-Port Copper X440-G2 managed switch features are:

- ▶ 12-ports of Tri-speed 10/100/1000Base-T
- ▶ Four 1000Base-X uplink Gigabit (SFP) ports configurable as 1G uplink ports. The SFP ports can accommodate 1000BASE-X GBICs only.
- ▶ RJ-45 Category 5 connectors on switch copper ports
- ▶ Full-duplex operation
- ▶ Configuration tasks through a local console port and monitoring through any SNMP/RMON based management application.
- ▶ Port mirroring technology and diagnostics that allow local network traffic to be redirected to an external probe for detailed analysis

- ▶ Compliance with industry standards, including IEEE 802.3u Fast Ethernet and 802.1w Rapid Spanning Tree Protocol (RSTP)
- ▶ Optional external (power brick style) redundant power supply
- ▶ Shelf, desk, or 19-inch rack mounting.

All X440-G2 switches ship with fixed fans and power supplies.

CPU/MEMORY

- ▶ 64-bit MIPS Processor, 1 GHz clock, single core
- ▶ 1GB ECC DDR3 DRAM
- ▶ 4GB eMMC Flash
- ▶ 1.5MB packet buffer

UPLINK/SWITCH INTERFACES:

Table 3 lists the MGBIC modules that can be added to the X440-G2, 12 copper Port Managed Switch (RH102AQ) switch. The MGBIC modules are added to specific SFP ports to provide connectivity for ISL ports.

POWER SUPPLY

The RH102AP switch power is provided by an internal power supply that requires separately fused 15-amp power circuits within 182 cm (6 ft) of the power supply.

OPTIONAL REDUNDANT POWER SUPPLY

Refer to “RH102AX (REDUNDANT POWER SUPPLY)” on page 65.

INSTALLATION GUIDELINES

NOTICE

POTENTIAL EQUIPMENT DAMAGE

These guidelines must be observed when a site is selected for this switch. If the guidelines are not followed, unsatisfactory network performance can result.

- ▶ To help ensure proper ventilation and help prevent overheating, leave a minimum clearance space of 5.1 cm (2.0 in) at the top, bottom, left, right, and rear of the switch. Do not connect the switch to the AC power source until instructed to do so later in the installation process.
- ▶ Ambient temperature at the installation site must be maintained between 0° and 50°C (32° to 122°F). Temperature changes must be maintained within 10°C (18°F) per hour.

Failure to follow these instructions can result in equipment damage.

FUNCTIONAL SPECIFICATIONS

RH102AQ 12- PORT COPPER / 8 - PORT FIBER X 440-G 2 MANAGED SWITCH

Ethernet Standards Supported

- ▶ IEEE 802.1q VLAN support
- ▶ IEEE 802.1d MAC Bridging (including STP) IEEE 802.1p
- ▶ Quality of Service (QoS, Priority) IEEE 802.1w Rapid Spanning Tree (RSTP) IEEE 802.3 including:
 - Fast Ethernet: IEEE 802.3u, 100Base-T (Copper)
 - Gigabit Ethernet: IEEE 802.3z, 1000Base-X (Fiber)
 - Gigabit Ethernet: IEEE 802.3ab, 1000Base-T (Copper)

Power

INTERNAL

AC Input power (auto-ranging)
100 V AC to 240 V AC, 50 to 60 Hz +/- 5%

EXTERNAL

Supports connection for redundant power supply

HEAT DISSIPATION

109 BTUs/hour

POWER CONSUMPTION

15 Watts

MAXIMUM POWER CONSUMPTION

32 Watts

ENVIRONMENTAL SPECIFICATIONS

Operating Conditions

TEMPERATURE

0° to 50°C (32° to 122°F)

RELATIVE HUMIDITY

10% to 95% (non-condensing)

ALTITUDE

0 to 3,000 meters (9,850 feet)

Storage Conditions

TEMPERATURE

-40° to +70°C (-40° to +158°F)

RELATIVE HUMIDITY

10% to 95% (non-condensing)

PHYSICAL SPECIFICATIONS

Mounting

Desk or Enclosure - 48.3 cm (19 in) equipment rack, 1U high

Dimensions

HEIGHT

4.4 cm (1.73 in)

WIDTH

30.5 cm (12.01 in)

DEPTH

26.1 cm (10.28 in)

Weight - Approximate

2.64 kg (5.82 lb)

Cable Connectors

UPLINK PORTS

RJ-45 copper or LC fiber

Vibration

Vibration - IEC 68-2-36, IEC 68-2-6

Shock - IEC 68-2-29

Drop - IEC 68-2-32

REGULATORY AND SAFETY

NORTH AMERICAN ITE

- ▶ UL 60950-1 2nd Ed., Listed Device (U.S.)
- ▶ CSA C22.2 No. 60950-1-07 2nd Ed. (Canada)
- ▶ Complies with FCC 21CFR 1040.10 (U.S. Laser Safety)
- ▶ CDRH Letter of Approval (US FDA Approval)

EUROPEAN ITE

- ▶ EN 60950-1:2006+A11+A1+A12+A2:2013
- ▶ EN 60825-1:2014
- ▶ EN 60825-2:2004+A1+A2
- ▶ TUV-R GS Mark by German Notified Body
- ▶ 2014/35/EU Low Voltage Directive

INTERNATIONAL ITE

- ▶ CB scheme: IEC 60950-1: 2005, 2nd Ed.+A1-2009 +A2:2013, + National Differences
- ▶ AS/NZX 60950-1 (Australia /New Zealand)

Electromagnetic Compatibility

2014/30/EU EMC Directive
EN 300-386 v1.6.1 (2012-09)
CISPR32:2014, Class A
EN 55032: 2014, Class A
CISPR11:2009+A1:2010, Class A
CISPR24:2010
EN 55024:2010
EN 300-386 v1.6.1 (2012-09)
EN 61000-6-2:2005

North America

FCC Part 15, Subpart B, Class A
ICES-003: 2012, Class A

REGULATORY AND SAFETY (CONTINUED)

Environmental

2011/65/EU RoHS Directive
EN 50581:2012

RH102AY 24- PORT COPPER X440-G2 MANAGED SWITCH



Figure 18. 24-Port Copper X440-G2 Managed Switch (RH102AY)

OVERVIEW

RH102AY (X440-G2 managed switch) provides 24 Tri-speed 10/100/1000Base-T ports with RJ-45 connectors, four (4) of which are combo ports (copper or SFP) and four (4) SFP+ ports (located on the back of the unit, ports 25-28). The four (SFP+) ports can be populated with 1000Base-X, or 100/1000Base-TX (RH102AL) MGBIC connector modules only.

The switch allows high performance, managed layer-2 Ethernet switching in small to medium sized network applications, as well as high performance direct end-station connectivity

FEATURES

The 12-Port Copper X440-G2 managed switch features are:

- ▶ 24-ports of Tri-speed 10/100/1000Base-T
- ▶ Four (4) combo ports 1000Base-X Gigabit (SFP) ports or fixed tri-speed 10/100/1000Base-T ports
- ▶ Four (4) SFP+ ports located on the back of the unit, 1000Base-X ISL ports only
- ▶ RJ-45 Category 5 connectors on switch copper ports
- ▶ Full-duplex operation
- ▶ Configuration tasks through a local console port and monitoring through any SNMP/RMON based management application
- ▶ Port mirroring technology and diagnostics that

allow local network traffic to be redirected to an external probe for detailed analysis

- ▶ Compliance with industry standards, including IEEE 802.3u Fast Ethernet and 802.1w Rapid Spanning Tree Protocol (RSTP)
- ▶ Optional external redundant power supply
- ▶ Shelf, desk, or 19-inch rack mounting.

All X440-G2 switches ship with fixed fans and power supplies.

CPU/MEMORY

- ▶ 64-bit MIPS Processor, 1 GHz clock, single core
- ▶ 1GB ECC DDR3 DRAM
- ▶ 4GB eMMC Flash
- ▶ 1.5MB packet buffer

UPLINK/SWITCH INTERFACES:

Table 3 lists the MGBIC modules that can be added to the X440-G2 24 port copper Port Managed Switch (RH102AY) switch. The MGBIC modules are added to specific SFP ports to provide connectivity for ISL or device ports.

POWER SUPPLY

The RH102AM switch power is provided by an internal power supply that requires separately fused 15-amp power circuits within 182 cm (6 ft) of the power supply.

OPTIONAL REDUNDANT POWER SUPPLY

INSTALLATION GUIDELINES

Refer to “RH102AX (REDUNDANT POWER SUPPLY)” on page 65.

NOTICE

POTENTIAL EQUIPMENT DAMAGE

These guidelines must be observed when a site is selected for this switch. If the guidelines are not followed, unsatisfactory network performance can result.

- ▶ To help ensure proper ventilation and help prevent overheating, leave a minimum clearance space of 5.1 cm (2.0 in) at the top, bottom, left, right, and rear of the switch. Do not connect the switch to the AC power source until instructed to do so later in the installation process.
- ▶ Ambient temperature at the installation site must be maintained between 0° and 50°C (32° to 122°F). Temperature changes must be maintained within 10°C (18°F) per hour.

Failure to follow these instructions can result in equipment damage.

FUNCTIONAL SPECIFICATIONS

RH102AY 24- PORT COPPER X440-G 2 MANAGED SWITCH

Ethernet Standards Supported

- ▶ IEEE 802.1q VLAN support
- ▶ IEEE 802.1d MAC Bridging (including STP) IEEE 802.1p
- ▶ Quality of Service (QoS, Priority) IEEE 802.1w Rapid Spanning Tree (RSTP) IEEE 802.3 including:
 - Fast Ethernet: IEEE 802.3u, 100Base-T (Copper)
 - Gigabit Ethernet: IEEE 802.3z, 1000Base-X (Fiber)
 - Gigabit Ethernet: IEEE 802.3ab, 1000Base-T (Copper)

Power

INTERNAL

AC Input power (auto-ranging)
100 V AC to 240 V AC, 50 to 60 Hz +/- 5%

EXTERNAL

Supports connection for redundant power supply

HEAT DISSIPATION

130 BTUs/hour

POWER CONSUMPTION

22 Watts

MAXIMUM POWER CONSUMPTION

38 Watts

ENVIRONMENTAL SPECIFICATIONS

Operating Conditions

TEMPERATURE

0° to 50°C (32° to 122°F)

RELATIVE HUMIDITY

10% to 95% (non-condensing)

ALTITUDE

0 to 3,000 meters (9,850 feet)

Storage Conditions

TEMPERATURE

-40° to +70°C (-40° to +158°F)

RELATIVE HUMIDITY

10% to 95% (non-condensing)

PHYSICAL SPECIFICATIONS

Mounting

Desk or Enclosure - 48.3 cm (19 in) equipment rack, 1U high

Dimensions

HEIGHT

4.4 cm (1.73 in)

WIDTH

44.1 cm (17.4 in)

DEPTH

25.4 cm (10.1 in)

Weight - Approximate

3.62 kg (7.98 lb)

Cable Connectors

UPLINK PORTS

RJ-45 copper or LC fiber

Vibration

Vibration - IEC 68-2-36, IEC 68-2-6

Shock - IEC 68-2-29

Drop - IEC 68-2-32

REGULATORY AND SAFETY

NORTH AMERICAN ITE

- ▶ UL 60950-1 2nd Ed., Listed Device (U.S.)
- ▶ CSA C22.2 No. 60950-1-07 2nd Ed. (Canada)
- ▶ Complies with FCC 21CFR 1040.10 (U.S. Laser Safety)
- ▶ CDRH Letter of Approval (US FDA Approval)

EUROPEAN ITE

- ▶ EN 60950-1:2006+A11+A1+A12+A2:2013
- ▶ EN 60825-1:2014
- ▶ EN 60825-2:2004+A1+A2
- ▶ TUV-R GS Mark by German Notified Body
- ▶ 2014/35/EU Low Voltage Directive

INTERNATIONAL ITE

- ▶ CB scheme: IEC 60950-1: 2005, 2nd Ed.+A1-2009 +A2:2013, + National Differences
- ▶ AS/NZX 60950-1 (Australia /New Zealand)

Electromagnetic Compatibility

2014/30/EU EMC Directive
EN 300-386 v1.6.1 (2012-09)
CISPR32:2014, Class A
EN 55032: 2014, Class A
CISPR11:2009+A1:2010, Class A
CISPR24:2010
EN 55024:2010
EN 300-386 v1.6.1 (2012-09)
EN 61000-6-2:2005

REGULATORY AND SAFETY (CONTINUED)

North America

FCC Part 15, Subpart B, Class A
ICES-003: 2012, Class A

Environmental

2011/65/EU RoHS Directive
EN 50581:2012

RH102AE 300W AC POWER SUPPLY (X460)



Figure 19. RH102AE 300W AC Power Supply (X460)

OVERVIEW

The X-Series (RH102AB/AC) switches have the capability to support power supply redundancy when installed with a second (optional) internal Power Supply Module (RPSM) (RH102AE).

The RH102AB/AC X-series managed switch's power supplies (RH102AE), ordered separately, automatically adjust to the input voltage and frequency. This allows for an input voltage of 85 to

264 V AC and a frequency between 47 and 63 Hz.

INSTALLATION GUIDELINES

To install an RH102AE power supply in an X460-G2 series switch, refer to *The Foxboro Evo Control Network Hardware and Software Configuration Instructions for X440-G2 and X460-G2 Series Switches* (B0700GV).

FUNCTIONAL SPECIFICATIONS

Power

AC Input power (auto-ranging)
85 V AC to 264 V AC, 47 to 63 Hz

HEAT DISSIPATION

109 BTUs/hour

ENVIRONMENTAL SPECIFICATIONS

Operating Conditions

TEMPERATURE

0° to 50°C (32° to 122°F)

RELATIVE HUMIDITY

10% to 95% (non-condensing)

ALTITUDE

0 to 3,000 meters (9,850 feet)

Storage Conditions

TEMPERATURE

-40° to +70°C (-40° to +158°F)

RELATIVE HUMIDITY

10% to 95% (non-condensing)

PHYSICAL SPECIFICATIONS

Mounting

Internal

Dimensions

HEIGHT

2.7 cm (1.06 in)

WIDTH

7.8 cm (3.09 in)

DEPTH

27.7 cm (10.9 in)

Weight - Approximate

1.02 kg (2.25 lb)

Vibration

Vibration - IEC 68-2-36, IEC 68-2-6

Shock - IEC 68-2-29

Drop - IEC 68-2-32

REGULATORY AND SAFETY

NORTH AMERICAN ITE

- ▶ UL 60950-1 2nd Ed., Listed Device (U.S.)
- ▶ CSA C22.2 No. 60950-1-07 2nd Ed. (Canada)
- ▶ Complies with FCC 21CFR 1040.10 (U.S. Laser Safety)
- ▶ CDRH Letter of Approval (US FDA Approval)

EUROPEAN ITE

- ▶ EN 60950-1:2006+A11+A1+A12+A2:2013
- ▶ EN 60825-1:2014
- ▶ EN 60825-2:2004+A1+A2
- ▶ TUV-R GS Mark by German Notified Body
- ▶ 2014/35/EU Low Voltage Directive

INTERNATIONAL ITE

- ▶ CB scheme: IEC 60950-1: 2005,2nd Ed.+A1-2009 +A2:2013, + National Differences
- ▶ AS/NZX 60950-1 (Australia /New Zealand)

Electromagnetic Compatibility

2014/30/EU EMC Directive

EN 300-386 v1.6.1 (2012-09)

CISPR32:2014, Class A

EN 55032: 2014, Class A

CISPR11:2009+A1:2010, Class A

EN 61000-3-2:2006+A2:2009

EN 61000-3-3:2013

EN 61000-6-4:2007+A1:2011

CISPR24:2010

EN 55024:2010

EN 300-386 v1.6.1 (2012-09)

EN 61000-6-2:2005

North America

FCC Part 15,Subpart B, Class A

ICES-003: 2012, Class A

Environmental

2011/65/EU RoHS Directive

EN 50581:2012

RH102AF: FAN MODULE (X460)



Figure 20. RH102AF: Fan Module (X460)

OVERVIEW

The RH102AB/AC X-Series managed switch requires a fan tray (RH102AF), ordered separately. If a fan stops working, the chassis FAN LED and the output of the CLI show system command indicate that the fan module has stopped working.

RH102AX (REDUNDANT POWER SUPPLY)



Figure 21. Redundant Power Supply (RH102AX)

OVERVIEW

NOTE

Two separate branch circuits are required for redundant power

The 156W redundant power supply (RH102AX) can supply redundant power for the P0973JM, P0973JN, P0973JP, P0973KJ, or P0973LK (SecureStack family of switches) and RH102AD, RH102AM, RH102AN, RH102AP or RH102AY (Summit family of switched) managed switches.

NOTE

The RH102AX RPS cannot be utilized for the RH102AQ switch.

The RH102AX PRS operates in a parallel capacity with the switch's internal power supply. In case, an AC power loss is detected or there is a detected failure of an internal power supply, the redundant

power supply supports the full load of the switch without affecting network operation.

The (RPS) redundant power supply (RH102AX) must be used with the (RPSC) Redundant Power Supply Chassis (RH102AV). This chassis does not have AC power connections or electronics.

The RH102AV power supply chassis accommodates three power supply units (RH102AX) which can support up to three switches as listed above.

FEATURES

The redundant power supply for the FECN qualified switches:

- ▶ Support for up to three managed switches (one supply/switch)
- ▶ Desktop, shelf, or 19-inch rack mounting

FUNCTIONAL SPECIFICATIONS

RH102AX REDUNDANT POWER SUPPLY

Power

AC INPUT RANGE

90 V AC to 264 V AC, 47 to 63 Hz

OUTPUT

+12.0 VDC, 13 A Max
102 W or 156 W continuous

ENVIRONMENTAL SPECIFICATIONS

Operating Conditions

TEMPERATURE

5° to 60°C (41° to 140°F)

RELATIVE HUMIDITY

10% to 90% (non-condensing)

Storage Conditions

TEMPERATURE

-45° to +85°C (-49° to +185°F)

RELATIVE HUMIDITY

10% to 90% (non-condensing)

PHYSICAL SPECIFICATIONS

Mounting

Redundant power supply chassis (RH102AV for three RPS)

Weight - Approximate

1.5 kg (3.3 lb)

Dimensions

HEIGHT

4.1 cm (1.61 in)

WIDTH

15.4 cm (6.1 in)

Depth

30.0 cm (11.8 in)

REGULATORY AND SAFETY

Electromagnetic Compatibility (EMC)

(Applies to P0973JV with eight power supplies installed and working with eight switches)
47 CFR Parts 2 and 15, CSA C108.8, 89/336/EEC, EN 55022, EN 61000-3-2, EN 61000-3-3, EN 55024; AS/NZS CISPR 22, and VCCI V-3

Location

UL/UL-C listed as suitable for use in ordinary locations and meets ordinary safety standards for fire and shock hazards.

Contamination

Class G1 (Mild) as defined in ISA Standard S71.04

Product Safety

UL 60950, CSA C22.2 No. 60950, 73/23/EEC, EN 60950, and IEC 60950

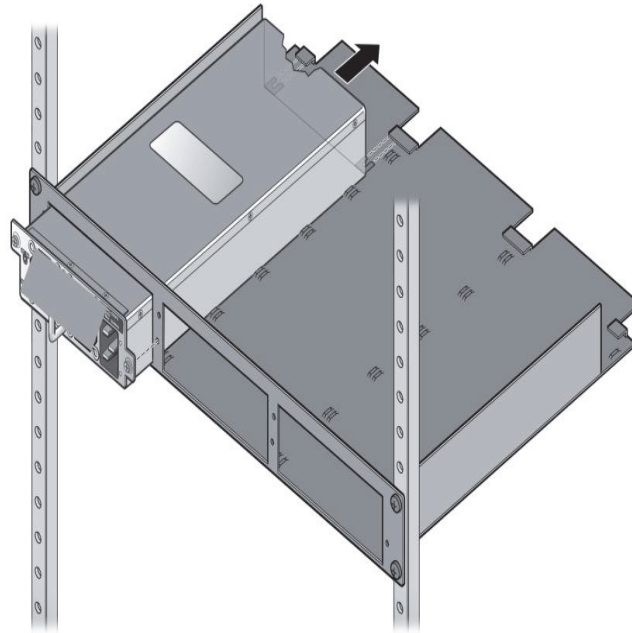

Figure 22. Redundant Power Supply Chassis (RH102AV) and Power Supply (RH102AX)

RH102AV REDUNDANT POWER SUPPLY CHASSIS

PHYSICAL SPECIFICATIONS

Mounting

Desk or Enclosure - 48.3 cm (19 in) equipment rack,
2Uhigh

Dimensions

HEIGHT

5.5 cm (2.2 in)

WIDTH

48.2 cm (19 in)

DEPTH

18 cm (7.0 in)

Weight - Approximate

0.95 kg (2.09 lb)

Power Supply Slots

Three slots for redundant power supplies
(RH102AX)

RH102AW (REDUNDANT POWER SUPPLY) FOR RH102AQ

OVERVIEW

NOTE

Two separate branch circuits are required for redundant power

The 90W redundant power supply (RH102AW) can supply redundant power for the RH102AQ switch.

The RH102AW PRS operates in a parallel capacity with the switch's internal power supply. In case, an AC power loss is detected or there is a detected failure of an internal power supply, the redundant power supply supports the full load of the switch without affecting network operation.

FEATURES

The redundant power supply for the FECN qualified switches:

- ▶ Desktop, shelf, rack mounting
- ▶ The RH102AW RPS is a "Brick" style power supply and can be installed in any location.
- ▶ Up to 90 W of power per supply

FUNCTIONAL SPECIFICATIONS

RH102AW REDUNDANT POWER SUPPLY

Power

AC INPUT RANGE

90 V AC to 264 V AC Hz, 47 to 63 Hz

OUTPUT

+19.0 VDC, 90 Watts

ENVIRONMENTAL SPECIFICATIONS

Operating Conditions

TEMPERATURE

0° to 40°C (32° to 104°F)

RELATIVE HUMIDITY

5% to 90% (non-condensing)

Storage Conditions

TEMPERATURE

-20° to +85°C (-4° to +185°F)

RELATIVE HUMIDITY

5% to 90% (non-condensing)

REGULATORY COMPLIANCE AND CERTIFICATION

Electromagnetic Compatibility (EMC)

(Applies to P0973JV with eight power supplies installed and working with eight switches)
47 CFR Parts 2 and 15, CSA C108.8, 89/336/EEC, EN 55022, EN 61000-3-2, EN 61000-3-3, EN 55024; AS/NZS CISPR 22, and VCCI V-3

Product Safety

UL 60950, CSA C22.2 No. 60950, 73/23/EEC, EN 60950, and IEC 60950

Location

UL/UL-C listed as suitable for use in ordinary locations and meets ordinary safety standards for fire and shock hazards.

Contamination

Class G1 (Mild) as defined in ISA Standard S71.04

Table 3. Mini-GBIC SFP Connector Modules For Each Switch Type

Switch Type Supported	Mini-GBIC SFP Connector Modules	
	Description	Foxboro Part No. Refer to Table 4 to determine the maximum range for each device and application.
All switch types that support SFP and SFP+ ports	SFP MMF module 1000Base-SX with LC connector, Multimode Fiber transmitting frequency @ 850nm	P0972WT - LC connector, Multimode Fiber
	SFP SMF module 1000Base-LX with LC connector, Single mode Fiber transmitting frequency @ 1310nm	P0972WU - LC connector, Single mode Fiber
	SFP MMF module 1000Base-LX/LH with LC connector, Multimode Fiber transmitting frequency @ 1300nm	P0972YQ - LC connector, Multimode Fiber
	SFP SMF module 1000Base-ZX with LC connector, Single mode Fiber transmitting frequency @ 1310nm	P0973FT - LC connector, Single mode Fiber
	SFP S-SMF module 1000Base-BX with LC connector, Bi-directional Simplex-Single mode Fiber transmitting frequency @ 1310nm / 1490nm downlink/uplink Mini- GBIC Kit - includes both P0973JB and P0973JC modules	P0973JD ^(a) - LC connector, Bi-directional Simplex-Single mode Fiber
	SFP S-SMF module 1000Base-BX with LC connector, Bi-directional Simplex-Single mode Fiber transmitting frequency @ 1310nm / 1490nm downlink/uplink Mini- GBIC Kit - includes both P0973KM and P0973KN modules	P0973KP ^(b) - LC connector, Bi-directional Simplex-Single mode Fiber

Table 3. Mini-GBIC SFP Connector Modules For Each Switch Type (Continued)

Switch Type Supported	Mini-GBIC SFP Connector Modules	
	Description	Foxboro Part No. Refer to Table 4 to determine the maximum range for each device and application.
	SFP S-SMF module 1000Base-BX with LC connector, Bi-directional Simplex-Single mode Fiber transmitting frequency @ 1310nm / 1490nm downlink/uplink Mini- GBIC Kit - includes both P0973KQ and P0973KR modules	P0973KS ^(c) - LC connector, Bi-directional Simplex-Single mode Fiber
1000Base-T is supported on all switch types that support SFP and SFP+ ports	SFP module 100/1000Base-T with RJ-45 connectors	RH102AL- RJ-45 connector, copper
100Base-T is supported on X-series switches and only SFP ports (No SFP+ ports)		
100Base-LX is supported on X-series, C-series and S-series switch types that support SFP ports (No SFP+ ports)	SFP MMF module 100Base-LX with LC connector, Multimode Fiber transmitting frequency @ 1310n	P0973JE - LC connector, Multimode Fiber

(a) Kit P0973JD is comprised of two Mini-GBICs (P0973JB and P0973JC). P0973JC transmits “downstream” (from the core of the network to the edge) uses the 1490 nm wavelength, and the “edge” P0973JB transmits “upstream” uses the 1310 nm wavelength.

(b) Kit P0973KP (40 km (25 mi)) is comprised of two Mini-GBICs (P0973KM and P0973KN). P0973KN transmits “downstream” (from the core of the network to the edge) uses the 1490 nm wavelength, and the “edge” P0973KM transmits “upstream” uses the 1310 nm wavelength over Simplex Single Mode Fiber (S-SMF).

(c) Kit P0973KS (120Km) is comprised of two Mini-GBICs (P0973KQ and P0973KR). P0973KR transmits “downstream” (from the core of the network to the edge) uses the 1590 nm wavelength, and the “edge” P0973KQ transmits “upstream” uses the 1490 nm wavelength over Simplex Single Mode Fiber (S-SMF) at a minimum distance of 30 km (19 mi).

OPERATING RANGE FOR MINI-GBIC UPLINK CONNECTOR MODULES

Link Power Budget

The maximum drive distance depends on the quality of the installed single-mode and multi-mode fiber-optic cable segment. Use the link power budget to calculate the maximum cable length of the attached segment. The link power budget must not be exceeded.

Table 4 lists the operating ranges for the Mini-GBIC connector modules that can be used with the control network switches. Refer to Table 3 for the Mini-GBIC modules which can be used with each switch type.

Table 4. Link Power Budget for Fiber Optic Mini-GBIC Modules^(a)

Product Part Number ^(b)	Cable Type	Tx/Rx Wavelength	MHz/km	Range	
				Min. (Meters)	Max. (Meters)
P0972WT	62.5µm	850	160	2	220
	62.5µm		200	2	275
	50µm		400	2	500
	50µm		500	2	550
P0972YQ	62.5µm	1310	160	2	2000
	50µm		400	2	1000
P0972WU	9-10µm	1310	-	-	10000
P0973FT ^(c)	9-10µm	1550	-	-	80000
P0973JB ^(d)	9µm	1310/1490	-	-	10000
P0973JC ^(d)	9µm	1490/1310	-	-	10000
P0973JE ^(e)	62.5µm	1310	160	2	2000
	50µm		400	2	1000
P0973KM ^(d)	9µm	1310/1490	-	5000	40000
P0973KN ^(d)	9µm	1490/1310	-	5000	40000
P0973KQ ^(d)	9µm	1490/1590	-	30000	120000
P0973KR ^(d)	9µm	1590/1490	-	30000	120000

(a) Transmission distances are provided as a nominal guide only. Refer to the optical specifications and the specific characteristics of your fiber installation to determine targeted distances.

(b) Industrial MGBIC to be used with I-Series industrial switch (P0973GA) with thermal limits of -40° to +60°C (-40° to +140°F). All other MGBICs are thermal rated at 0° to +50°C (32° to +122°F).

(c) Do not use the P0973FT MGBIC over distances less than 8 km (5.0 mi).

(d) P0973JB/JC, P0973KM/KN and P0973KQ/KR are bi-directional Mini-GBICs. Both upstream and downstream switches transmit on the same fiber but at different frequencies. When ordering these Mini-GBICs, you must acquire a matching pair, one of each type. For a matching pair, order kits P0973JD (10 km (6.2 mi)), P0973KP (40 km (25 mi)), or P0973KS (120 km (74.6 mi)) which include one of each of the modules.

(e) This Mini-GBIC (P0973JE) is not to be used as an uplink (ISL) port. This Mini-GBIC has been qualified to be used for an end device (CP, ATS, FCM, workstation, etc.) 100Mb switch port.

MEDIA CONVERTER 100BASE-FX TO 100BASE-TX (P0972XH_D)



Front View

Figure 23. Media Converter 100Base-FX to 100Base-TX (P0972XH_D)

OVERVIEW

The Media Converter (P0972XH) supports mixed media networks by enabling copper-to-fiber media conversion. It includes auto-recovery to automatically restore link on the fiber line after a link loss event. Auto-recovery works in conjunction with Link Loss Return and Link Loss Carry Forward to identify the detected loss of a remote network connection. Its impact-resistant enclosure is made of high durability, fade-resistant plastic.

FEATURES

The features of the Media Converter (P0972XH) are:

- ▶ Copper RJ-45 to MT-RJ fiber media conversion
- ▶ 100Mbps speed adaptation
- ▶ Multimode fiber up to 2 km
- ▶ Link Loss Carry Forward, (LLCF) and Link Loss Return (LLR) aids in troubleshooting a remote network connection for all fiber optic ports
- ▶ Auto-Recovery restarts fiber link between two back-to-back line cards after a link loss event
- ▶ MDI-II to MDI-X switch helps eliminate the need for crossover cables on twisted-pair ports.

FUNCTIONAL SPECIFICATIONS

MEDIA CONVERTER 100BASE-FX TO 100BASE-TX (P0972XH_D)

Link Length

MMF, 2 km (1.25 mi)
CAT 5 cable, 100 m (330 ft)

Power Consumption

10 W

Power Internal

AC Input power (auto-sensing)
100 V AC to 240 V AC, 50 to 60 Hz

ENVIRONMENTAL SPECIFICATIONS

Operating Conditions

TEMPERATURE

0° to +50°C (32° to + 122°F)

RELATIVE HUMIDITY

5% to 95% (noncondensing)

Storage Conditions

TEMPERATURE

-25° to +70°C (-13° to +158°F)

RELATIVE HUMIDITY

5% to 95% (noncondensing)

PHYSICAL SPECIFICATIONS

Dimensions - Nominal (19-inch Rack Width)

HEIGHT

26 mm (1.02 in)

WIDTH

70 mm (2.76 in)

DEPTH

97 mm (3.82 in)

Mounting

Desk, shelf, or wall mount

Weight - Approximate

0.55 kg (1.2 lb)



Schneider Electric Systems USA, Inc
38 Neponset Avenue
Foxborough, MA 02035-2037
United States of America
www.schneider-electric.com

Global Customer Support
<https://pasupport.schneider-electric.com>

Copyright 2016-2018 Schneider Electric.
All rights reserved.

Schneider Electric, Foxboro, Foxboro Evo, and I/A Series are trademarks of Schneider Electric SE, its subsidiaries and affiliates.
All other trademarks are the property of their respective owners.

MB 031

0818