



# Foxboro™ DCS

## FBM232 Field Device System Integrator Module, 10/100 Mbps Ethernet, Single

### PSS 41H-2S232

#### Product Specification

May 2023



# Legal Information

The Schneider Electric brand and any trademarks of Schneider Electric SE and its subsidiaries referred to in this guide are the property of Schneider Electric SE or its subsidiaries. All other brands may be trademarks of their respective owners.

This guide and its content are protected under applicable copyright laws and furnished for informational use only. No part of this guide may be reproduced or transmitted in any form or by any means (electronic, mechanical, photocopying, recording, or otherwise), for any purpose, without the prior written permission of Schneider Electric.

Schneider Electric does not grant any right or license for commercial use of the guide or its content, except for a non-exclusive and personal license to consult it on an "as is" basis. Schneider Electric products and equipment should be installed, operated, serviced, and maintained only by qualified personnel.

As standards, specifications, and designs change from time to time, information contained in this guide may be subject to change without notice.

To the extent permitted by applicable law, no responsibility or liability is assumed by Schneider Electric and its subsidiaries for any errors or omissions in the informational content of this material or consequences arising out of or resulting from the use of the information contained herein.

# Overview

*The FBM232 Field Device System Integrator (FDSI) module provides a single Ethernet interface between single-ported field I/O devices and the EcoStruxure™ Foxboro™ DCS system.*

The FBM232 connects to a single 10 Mbps or 100 Mbps copper Ethernet network to communicate with devices. The FBM232 is connected to Ethernet switches or hubs in order to communicate with one external device or up to 64 external devices.

The general network configuration is shown in Figure 1, page 4.

# Features

Key features of the FBM232 are:

- 10 Mbps or 100 Mbps Ethernet network transmission rate to/from field device
- Communicates with up to 64 field devices
- I/O software driver is downloadable from a library of available protocols
- Up to 2000 DCI block connections
- Integrates field device data into a Foxboro DCS control database using Ethernet connectivity
- Field mounted
- Class G3 (harsh) environments.

# I/O Drivers

This fieldbus module (FBM) is a generic Ethernet hardware module in which different software drivers can be loaded. These drivers configure the FBM to recognize a particular protocol used by the device. Several of the software drivers are standard product offerings. Other custom drivers can be developed to meet specific needs.

These drivers are dynamically downloaded to the FBM232 with software code specifically designed to interface with the third party device's protocol. The configuration procedures and the software requirements for each driver are unique to the device(s) being integrated into the system.

**Figure 1. FBM232 in Typical Network Configuration**

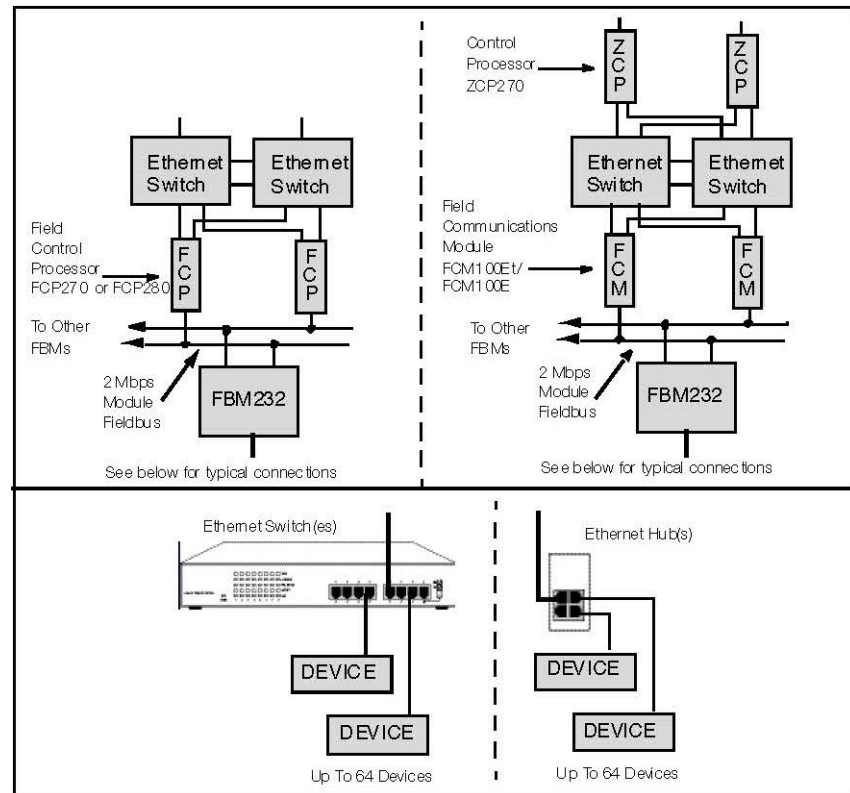

## Ethernet Link Setup

Data communication between the FBM232 and field devices are through the RJ-45 connector located on the front of the FBM232 module. The RJ-45 connector of the FBM232 can be connected through hubs, or through Ethernet switches to the field devices (refer to *Ethernet Switches for Use with FBM232*, page 12). Connection of multiple devices to the FBM232 requires a hub or switch.

## Configurator

The FDSI configurator sets up the FBM232 XML based port and device configuration files. The port configurator allows for easy setup of the communication parameters for each port (such as, Dynamic Host Configuration Protocol (DHCP), IP addresses). The device configurator is not needed for all devices, but when needed it configures device specific and point specific considerations (such as, scan rate, address of the data to be transferred, and the amount of data to be transferred in one transaction).

## Operations

The FBM232 can access up to 64 devices to read or write data. From the Foxboro DCS control station to which the FBM232 is connected, up to 2000 Distributed Control Interface (DCI) data connections can be made to read or write data. Supported data types are determined by the particular driver loaded on the FBM232, which converts the data to the DCI data types listed below:

- An analog input or output value (integer or IEEE single-precision floating point)
- A single digital input or output value
- Multiple (packed) digital input or output values (packed in groups of up to 32 digital points per connection).

Thus the FBM232 can access up to 2000 analog I/O values, or up to 64000 digital I/O values, or a combination of digital and analog values up to the maximum capacity a user allows within the sizing guidelines of the control processor. The frequency of access to the FBM232 data by a control station can be as fast as 500 ms. The performance depends on each device type and the layout of data in the device.

The FBM232 collects the required data from the devices, performs the necessary conversions, and then stores the converted data in its database for incorporation into the Foxboro DCS plant management functions and operator displays. Data may also be written out to the individual devices from the Foxboro DCS system.

## Fieldbus Communications

The Fieldbus Communications Module (FCM100Et or FCM100E) or the Field Control Processor (FCP270 or FCP280) interface the redundant 2 Mbps module Fieldbus used by the FBMs. The FBM232 accepts communication from either path of the redundant 2 Mbps module Fieldbus - should one path fail or be switched at the system level, the module continues communication over the active path.

## Control Block Support

The FBM232 offers control block support for the following standard Foxboro DCS Distributed Control Interface (DCI) block types:

BIN	Binary Input
BINR	Binary Input Redundant
BOUT	Binary Output
IIN	Integer Input
IOUT	Integer Output
PAKIN	Packed Input
PAKOUT	Packed Output
PLSOUT	Pulse Output
RIN	Real Input
RINR	Real Input Redundant
ROUT	Real Output
STRIN	String Input
STROUT	String Output

The DCI blocks are configured just like other Foxboro DCS control blocks. The DCI blocks address and read/write data from/to the addressed field device.

## Standard, Rugged Design

The FBM232 has a rugged extruded aluminum exterior for physical and electrical protection of the circuits. Enclosures, specially designed for mounting the FBMs, provide various levels of environmental protection, up to Class G3 harsh environments per ISA Standard S71.04.

## Modular Baseplate Mounting

The module mounts on a Modular Baseplate, which accommodates up to four or eight FBMs. The Modular Baseplate is either DIN rail mounted or rack mounted. The Modular Baseplate includes signal connectors for the FBMs, provides connections for independent dc power supplies, I/O cable connections, and 2 Mbps Module Fieldbus connections.

## Easy Removal/Replacement

The module can be removed or replaced without removing power.

## Visual Indicators

Light-emitting diodes (LEDs) incorporated into the front of the module provide visual indication of the module's operational status, and the communication activity (transmit/receive) of the Ethernet port.

# Functional Specifications

<p>Communications</p>	<p>Bus Characteristics</p> <ul style="list-style-type: none"> <li>• Communication Type Ethernet</li> <li>• Communication Transmission Rate 10 or 100 Mbps</li> <li>• Communication Protocol UDP/IP or TCP/IP</li> <li>• IP Address Fixed or DHCP</li> </ul> <p><b>NOTE:</b> For driver specific limitations on I/O Capacity and Data Types Transferred, refer to the corresponding driver PSS or User’s Guide.</p> <p>I/O Capacity</p> <ul style="list-style-type: none"> <li>• Up to 64 devices per FBM232 maximum (number of actual devices is performance dependent) with up to 2000 DCI connections.</li> </ul> <p>Data Types Transferred</p> <ul style="list-style-type: none"> <li>• 2-byte or 4-byte signed or unsigned integers, 4-byte IEEE single-precision floating values, or binary values. Automatic conversion for other types as implemented in the downloadable driver.</li> </ul> <p>Fastest Allowed ECB Block Period</p> <ul style="list-style-type: none"> <li>• 500 msec</li> </ul>
<p>Module Fieldbus Communication</p>	<p>Communicates with its associated FCM100Et, FCM100E, FCP280, or FCP270 via the redundant 2 Mbps module Fieldbus.</p>
<p>FBM232 Power Requirements</p>	<ul style="list-style-type: none"> <li>• Input Voltage Range (Redundant) 24 V DC +5%, -10%</li> <li>• Consumption 7 W (maximum)</li> <li>• Heat Dissipation 7 W (maximum)</li> </ul>
<p>Regulatory Compliance, Electromagnetic Compatibility (EMC)</p>	<p>European EMC Directive 2014/30/EU Meets: EN61326-1:2013 Class A Emissions and Industrial Immunity Levels</p>



<p>Regulatory Compliance, Product Safety</p>	<ul style="list-style-type: none"> <li>• <i>Underwriters Laboratories (UL) for U.S. and Canada</i>                      UL/UL-C listed as suitable for use in UL/UL-C listed Class I, Groups A-D; Division 2; temperature code T4 enclosure based systems when connected to specified Foxboro DCS processor modules as described in the <i>Standard and Compact 200 Series Subsystem User's Guide (B0400FA)</i>.                       Communications circuits also meet the requirements for Class 2 as defined in Article 725 of the National Electrical Code (NFPA No.70) and Section 16 of the Canadian Electrical Code (CSA C22.1). Conditions for use are as specified in the <i>Standard and Compact 200 Series Subsystem User's Guide (B0400FA)</i>.</li> <li>• <i>European Low Voltage Directive 2014/35/EU and Explosive Atmospheres (ATEX) Directive 2014/34/EU</i>                       DEMKO certified as Ex nA IIC T4 for use in certified Zone 2 enclosure when connected to specified processor modules as described in the <i>Standard and Compact 200 Series Subsystem User's Guide (B0400FA)</i>.</li> <li>• <i>Marine Certification</i>                       ABS Type Approved and Bureau Veritas Marine certified for Environmental Category EC31.</li> </ul>
<p>Calibration Requirements</p>	<p>Calibration of the module is not required.</p>

## Environmental Specifications

	<b>Operating</b>	<b>Storage</b>
<b>Temperature</b>	Rev A to J: -20 to +70°C (-4 to +158°F) Rev K and later: 0 to +70°C (32 to +158°F)	-40 to +70°C (-40 to +158°F)
<b>Relative Humidity</b>	5 to 95% (noncondensing)	5 to 95% (noncondensing)
<b>Contamination</b>	Suitable for use in Class G3 (Harsh) environments as defined in ISA Standard S71.04, based on exposure testing according to EIA Standard 364-65, Class III.	

## Physical Specifications

Mounting	The FBM232 mounts on a Modular Baseplate. The Modular Baseplate can be mounted horizontally or vertically on a DIN rail, or mounted horizontally in a 19-inch rack using a mounting kit. Refer to PSS 31H-2SBASPLT for details.
Weight	284 g (10 oz) approximate
Part Number	P0926GW
Dimensions	<ul style="list-style-type: none"><li>• Height: 102 mm (4 in) 114 mm (4.5 in) including mounting lugs</li><li>• Width: 45 mm (1.75 in)</li><li>• Depth: 104 mm (4.11 in)</li></ul>
Cables	<ul style="list-style-type: none"><li>• From Module to Hub/Switch/Device 1 m (3.3 ft) to 100 m (330 ft)</li><li>• Connectors RJ-45</li><li>• Null Hub Adapter Cable P0971PK</li></ul>

## Ethernet Switches for Use with FBM232

### DIN Rail Mounted 5-Port 10/100 Base TX Switch

The 5-port 10/100 base TX Ethernet switch (P0972WE) is Din rail mounted and available for use with the FBM232. You can connect up to four Ethernet devices using this 5-port switch. Additionally, multiple switches can be interconnected to connect up to 64 devices to a single FBM232.

For detailed physical and electrical specifications, refer to *Model SFNB 5TX 2891001* at [www.phoenixcontact.com/us/products](http://www.phoenixcontact.com/us/products).

**Figure 2. 5-Port 10/100 Base TX DIN Rail Mounted Ethernet Switch (P0972WE)**



### Rack and Chassis Mounted Fast Ethernet Switches

For information on the Fast Ethernet switches, refer to *The Foxboro DCS Control Network Ethernet Equipment* (PSS 41H-7NWEQUIP).

## Related Product Specification Sheets

<b>PSS Number</b>	<b>Description</b>
PSS 31H-2SOV	Standard 200 Series Subsystem Overview
PSS 31H-2CERTS	Standard and Compact 200 Series I/O - Agency Certifications
PSS 41H-7NWEQUIP	The Foxboro DCS Control Network Ethernet Equipment

 **WARNING:** This product can expose you to chemicals including lead and lead compounds, which are known to the State of California to cause cancer and birth defects or other reproductive harm. For more information, go to [www.p65warnings.ca.gov/](http://www.p65warnings.ca.gov/).

Schneider Electric Systems USA, Inc.  
70 Mechanic Street  
Foxboro, Massachusetts 02035–2040  
United States of America

Global Customer Support: <https://pasupport.se.com>

As standards, specifications, and design change from time to time, please ask for confirmation of the information given in this publication.

© 2015–2023 Schneider Electric. All rights reserved.

PSS 41H-2S232, Rev. B