

GPD 503 Technical Manual



GPD 503 SIMPLIFIED START-UP PROCEDURE

This procedure will quickly get you up and running by Digital Operator keypad or user supplied remote operator control. It assumes that the GPD 503 and motor are correctly wired (see pages 1-8 thru 1-15), and start-up is to be performed without any changes to factory set constants. Detailed information on the many other features of this drive will be found in later sections of this manual.

INSTALLATION

1. Be certain your input voltage source, motor, and drive name plates are all marked either 230V, 460V, or 575V. Other voltages can be used, but require additional programming, see Section 2.
2. Mount drive on a vertical surface with adequate space for air circulation.
3. Remove front cover, fit conduit to bottom plate, and connect power and ground wires as shown.

CAUTION

Be certain you connect input power to terminals L1, L2, and L3 only, or serious damage will result. Connect motor to terminals T1, T2, and T3 only.

KEYPAD OPERATION

1. **Replace cover and apply input power** - keypad display shows "**F00.00**"; **DRIVE**, **FWD**, and **STOP** lamps are on. Press and hold **JOG** key, noting direction of motor rotation. If it is incorrect, remove power, wait for "CHARGE" light to go out, then switch wires between terminals T1, and T2. Replace cover, and apply input power.
2. **Run, Stop, and Frequency (Speed)** - Here, the terms frequency and speed are used interchangeably. A value of 60.00 (Hz) in the "**F00.00**" display equals full speed (frequency) for common motors. Press **RUN** key; **RUN** lamp lights, **STOP** lamp flashes (to indicate drive is running at zero speed). Note flashing "0" in "**F00.00**" display. Press "up arrow" key one time to increase display frequency value to **10.00**. Press **DATA/ENTER** key to enter speed data, noting that motor shaft begins to turn. Repeat this procedure using "up arrow", "down arrow" and "right arrow" (**RESET**) keys to introduce various speeds, noting that the drive responds to each new value only after the **DATA/ENTER** key is pressed. The "**F00.00**" display indicates the frequency command the drive is looking at, whether it is running or not.
3. **Reversing** - can be selected while stopped, or while running. With the drive stopped, press **FWD/REV** key and note the **REV** lamp lights and **FWD** lamp goes out. If drive is running when this key is pressed, the drive will decelerate the motor to 0 Hz, then accelerate the motor to the same speed in the opposite direction. You can try this while running, provided your machine can be operated in reverse direction without damage.
4. **Displays** - With drive stopped, each time the **DISPL** (display) key is pressed, a different function appears. The first function on power up is the "**F00.00**" display, discussed above. Press **DISPL** and "**0.00**" appears; this is a display of output frequency (speed) and is recognized as the only display without alpha characters. The next is "**0.0A**"; the "**A**" indicates this display is output amps. For other display information, refer to Section 3.
5. **Faults** - If an unacceptable operating condition such as code **Ou** (over voltage), **Uu** (under voltage), **OC** (over current), etc. occurs, the drive will trip, and the motor will coast to a stop. The appropriate fault code will be displayed. Examine fault code; consult Sections 6 & 7 for fault correction procedure.

INSTALLATION OF EXTERNAL RUN/STOP SWITCH AND SPEED POTENTIOMETERS

IMPORTANT: Complete the INSTALLATION and KEYPAD OPERATION instructions before attempting external control.

1. Disconnect power, remove cover, and wait for "CHARGE" light to go out.
2. Refer to the diagram below and connect a switch to terminals 1 and 11 using two conductor shielded wire. This circuit is 24Vdc, very low current; use a quality rotary or toggle switch (all wire should be 14-18AWG). Connect the shield to terminal 12 on the drive end only.
3. Install a single conductor "jumper" wire between drive terminals 5 and 11.
4. Connect a manual speed potentiometer rated 2000-3000 ohms, 1 watt minimum, using three conductor shielded wire, with shield connected at terminal 12. Connect wires to the potentiometer as shown, viewing potentiometer from the back. Trace wire shown closest to the top in diagram (right side of potentiometer) and connect to terminal 17. Trace center wire of potentiometer through and connect to terminal 16. The remaining wire will be connected to the trim pot in step 5.
5. Connect a trim potentiometer rated 2000-3000 ohms, 1 watt minimum, as close to the drive terminals as possible. Viewing the potentiometer from the back, connect a single conductor wire from the left terminal to terminal 15 of the drive. Connect a short jumper wire between the center and left terminals. Connect remaining wire from manual speed pot as shown.

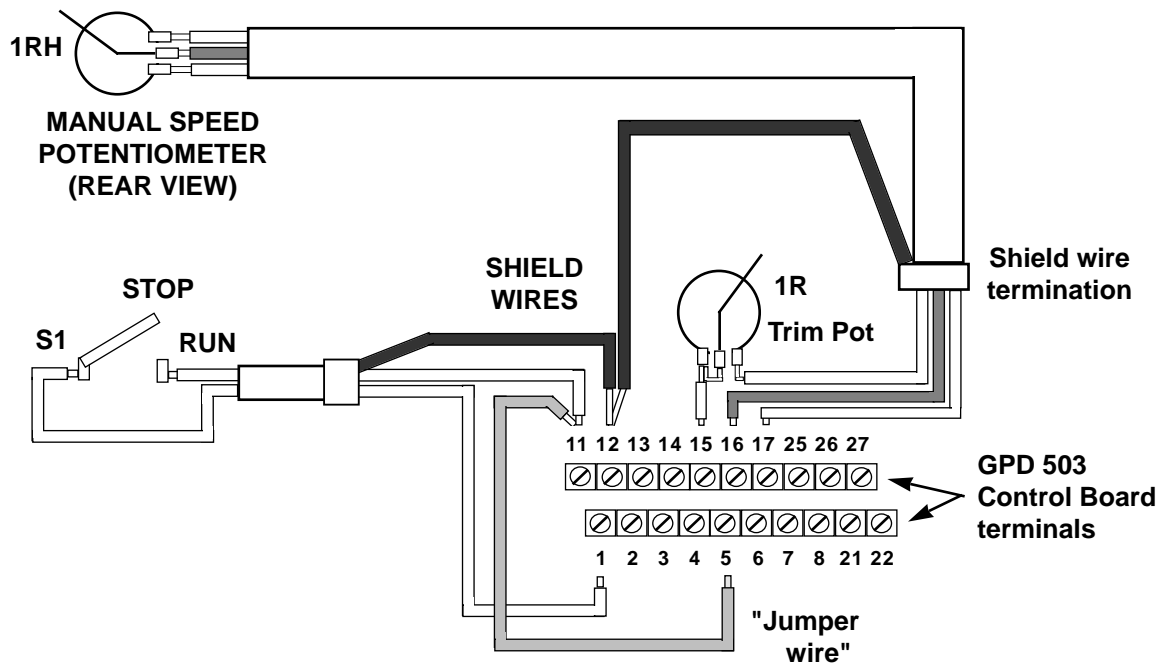

IMPORTANT: Programming is required to set up the drive for operation from external terminals.

6. Replace cover, make sure remote switch S1 is in "Stop" position, then apply power. Note that the **DRIVE** lamp is on. Press **DRIVE/PROGRAM** key, noting the **DRIVE** lamp goes out, indicating drive is in the "Program mode". The display will show "**Sn-01**", which is a constant (address). Press the "up arrow" (**RESET**) key three times to change constant to "**Sn-04**". Press the **DATA/ENTER** key; the display will show "**0011**", and the left **0** will be flashing. Using the same procedure used in setting the speed in "KEYPAD OPERATION", move to the first **1** and change it to **0**; then move to the remaining **1** and also change it to **0**. The display should now read "**0000**". Press the **DATA/ENTER** key to change the contents of constant Sn-04 to this new value. Display will momentarily show "**End**".
7. Press **DRIVE/PROGRAM** key, noting **DRIVE** lamp turns on; you have returned to the "Drive mode".
8. Calibrate manual speed pot for maximum speed at maximum rotation. With switch S1 in the "Stop" position, press **DISPL** key repeatedly, stopping at the "**FX.XX**" display. The display will be indicating the combined setting of the trim, and manual speed pots. Turn manual speed pot (as viewed from the front) to the right (maximum) setting. Turn trim pot slowly until "**F59.00**" is displayed, then advance just enough to display "**F60.00**".
9. Press **DISPL** key to move to output frequency display, turn switch S1 to "Run", and adjust motor speed with manual speed pot.

QUICK REFERENCE FOR GPD 503 CONSTANTS (FACTORY SET)

CONSTANT NUMBER	FACTORY SETTING	USER SETTING	CONSTANT NUMBER	FACTORY SETTING	USER SETTING	CONSTANT NUMBER	FACTORY SETTING	USER SETTING
An-01	0.00		Sn-22	02		Cn-29	50	
An-02	0.00		Sn-23	00		Cn-30	160	
An-03	0.00		Sn-24	00		Cn-31	(4)	
An-04	0.00		Sn-25	0000		Cn-32	(4)	
An-05	0.00		Sn-26	0000		Cn-33	(4)	
An-06	0.00		Sn-27	0010		Cn-34	30 (3)	
An-07	0.00		Sn-28	0100		Cn-35	2.0	
An-08	0.00					Cn-36	0	
An-09	6.00					Cn-37	(4)	
bn-01	10.0		Cn-01	230.0 (230V)		Cn-38	150	
bn-02	10.0			or 460.0 (460V)		Cn-39	2.0 (4)	
bn-03	10.0			or 575.0 (575V)		Cn-40	(4)	
bn-04	10.0		Cn-02	(2)		Cn-41	100	
bn-05	100.0		Cn-03	(2)		Cn-42	0.3	
bn-06	0		Cn-04	(2)		Un-01	N/A	N/A
bn-07	1.0		Cn-05	(2)		Un-02	N/A	N/A
bn-08	0.0		Cn-06	(2)		Un-03	N/A	N/A
bn-09	80		Cn-07	(2)		Un-04	N/A	N/A
bn-10	1		Cn-08	(2)		Un-05	N/A	N/A
bn-11	1.00		Cn-09	(1)		Un-06	N/A	N/A
bn-12	0.50		Cn-10	1.5 (2)		Un-07	N/A	N/A
Sn-01	(1)		Cn-11	50		Un-08	N/A	N/A
Sn-02	01		Cn-12	0.0		Un-09	N/A	N/A
Sn-03	0000		Cn-13	0.0		Un-10	N/A	N/A
Sn-04	0011		Cn-14	100				
Sn-05	0000		Cn-15	0				
Sn-06	0000		Cn-16	0.0				
Sn-07	0000		Cn-17	0.0				
Sn-08	0100		Cn-18	0.0				
Sn-09	0000		Cn-19	1.0				
Sn-10	0000		Cn-20	0				
Sn-11	0000		Cn-21	0.0				
Sn-12	0100		Cn-22	2.0				
Sn-13	0100		Cn-23	(4)				
Sn-14	0000		Cn-24	(4)				
Sn-15	03		Cn-25	00				
Sn-16	04		Cn-26	160				
Sn-17	06		Cn-27	0.1				
Sn-18	08		Cn-28	170				
Sn-19	00							
Sn-20	00							
Sn-21	01							

- (1) Setting depends on GPD 503 rating. See Table A3-1.
- (2) Initial value is related to V/f curve selected by Sn-02 setting.
- (3) Motor rated current (Cn-09) is set at 100% level. Setting range: 10 to 200% of GPD 503 rated capacity.
- (4) Initial value differs depending on GPD 503 capacity.

Horsepower Range

RATED INPUT	HORSEPOWER		MODEL NO.
	CT (150% OL)	VT (125% OL)	
2 3 0 V	1	1	DS305
	2	2	DS302
	3	3	DS306
	5	5	DS307
	7.5	7.5/10	DS308
	10	15	DS309
	15	20	DS310
	20	25	DS311
	25	30	DS322
	30	40	DS323
	40	50	DS2040
	40/50	50	GPD503-2L40
	50	60	DS2050
	60	60	GPD503-2L50
	60	75	DS2060
	60	75	GPD503-2L60
	75	100	DS2075
75	100	GPD503-2L75	
100	150	DS2100	
100	125	GPD503-2L100	
4 6 0 V	1	1	DS313
	2	2	DS304
	3	3	DS314
	5	5	DS315
	7.5	7.5/10	DS316
	10	15	DS317
	15	20	DS318
	20	25	DS326
	25	30	DS325
	30	40	DS330
	40	50	DS340
	50	60	DS350
	60	75	DS360
	75	100	DS075
	75/100	100	GPD503-4L75
	100	150	DS100
	100	150	GPD503-4L100
150	200	DS150	
150	200	GPD503-4L150	
200	250	DS200	
200	250	GPD503-4L200	
250	300	DS250	
300	400	DS303	
400	500	DS400	
5 7 5 V	2	3	DS5003
	3	3	DS5004
	5	5	DS5006
	7.5	7.5	DS5009
	10	10	DS5012
	15	15	DS5017
	20	20	DS5022
	25	25	DS5027
	30	30	DS5032
	40	40	DS5043
	50	50	DS5054
	60	60	DS5064
	75	75	DS5081
100	100	DS5112	
125	150	DS5130	
150	200	DS5172	
200	200	DS5202	

WARNING

Do not touch circuit components until main input power has been turned off and “CHARGE” lamp is extinguished. The capacitors are still charged and can be quite dangerous.

Do not connect or disconnect wires and connectors while power is applied to the circuit.

CAUTION

Know your application before using either Initialization function of Sn-03. This constant must be set to 0000 for Drive mode operation. (See paragraph 2.25 for additional information.)

1110 = Factory 2-Wire Control Initialization (Maintained RUN Contact)

1111 = Factory 3-Wire Control Initialization (Momentary START/STOP Contact)

Entering either Initialization code resets all constants EXCEPT Sn-01 AND Sn-02 to factory settings, and automatically returns Sn-03 setting to 0000. If the GPD 503 is connected for 3-Wire control and this constant is set to 1110 (2-Wire Control Initialization), the motor may run in reverse direction WITHOUT A RUN COMMAND APPLIED. Equipment damage or personal injury may result.

IMPORTANT

Always ground the GPD 503 using ground terminal G (E). See paragraph 1.4.3, "Grounding".

Never connect main circuit output terminals T1, T2, and T3 to AC main circuit power supply.

All constants have been factory set. Do not change their settings unnecessarily.

Do not perform a “HIPOT” voltage test on any part of the GPD 503. Equipment uses semi-conductors and is vulnerable to high voltage.

The Control PCB employs CMOS ICs which are easily damaged by static electricity. Use proper electrostatic discharge (ESD) procedures when handling the Control PCB.

CONTENTS

SUBJECT	PAGE
GPD 503 SIMPLIFIED START-UP PROCEDURE	i
HORSEPOWER RANGE	v
WARNING/CAUTION STATEMENTS	vi
1	INSTALLATION
1.1	General
1.2	Receiving
1.3	Physical Installation
1.4	Electrical Installation
1.4.1	Main Circuit Input/Output
1.4.2	Control Circuit
1.4.3	Grounding
1.4.4	Auxiliary Input and Output Power Option Devices
	Figure 1-3. 230V or 450V Interconnections - 2-Wire Control ..
	Figure 1-4. 230V or 460V Interconnections - 3-Wire Control .
	Figure 1-5. 575V Interconnections - 2-Wire Control
	Figure 1-6. 575V Interconnections - 3-Wire Control
2	PROGRAMMABLE FEATURES
2.1	General
2.2	Accel/Decel Time
2.3	Auto Reference Characteristics
2.4	Auto Reference - Loss Detection
2.5	Auto-restart
2.7	Critical Frequency Rejection
2.8	DC Injection Braking
2.9	Digital Display Selection
2.10	Display - Monitor (at Power-up) Selection
2.11	Energy Saving Operation
2.12	External Fault Terminal
2.13	Frequency (Auto) Command Bias/Gain
2.14	Frequency Command Upper & Lower Limits
2.15	Jog Reference
2.16	Momentary Power Loss Ride-thru
2.17	Monitor Display (Digital Operator)
2.18	Multi-function Analog Input (Term. 16)
2.19	Multi-function Input Terminals (Term. 5-8)
2.20	Multi-function Analog Monitor Output (Term. 21 & 22)
2.21	Multi-function Output Terminals (Term. 9 & 10; 25-27)
2.22	Overtorque Detection
2.23	Speed Coincidence
2.24	Remote/Local and Reference Selection
2.25	Reset Codes (2-Wire, 3-Wire Initialization)
2.26	Slip Compensation
2.27	Soft Start (S-Curve) Characteristics
2.28	Speed Search
2.29	Stall Prevention

CONTENTS - Continued

SUBJECT	PAGE
2.30	Thermal Motor Overload Protection 2-46
2.31	Torque Compensation 2-46.2
2.32	V/f Pattern - Standard 2-46.2
2.33	V/f Pattern - Custom 2-48
2.34	Up/Down Frequency Setting 2-50
2.35	Slip Compensation Primary Time Delay 2-51
2.36	Carrier Frequency 2-52
3	DIGITAL OPERATOR 3-1
3.1	General 3-1
3.2	Display and Keypad 3-1
3.3	Comparison of Program Mode and Drive Mode 3-4
3.4	Program Mode Operation 3-5
3.5	Drive Mode Operation 3-7
4	INITIAL START-UP ("LOCAL" CONTROL) 4-1
4.1	Pre-power Checks 4-1
4.2	Test Run Using Digital Operator ("Local" Control) 4-2
4.3	Pre-operation Considerations 4-4
4.4	Storage Function 4-4
5	OPERATION AT LOAD 5-1
6	FAILURE INDICATION AND DETAILS 6-1
6.1	General 6-1
6.2	Displaying Fault Sequence 6-4
7	TROUBLESHOOTING 7-1
App. 1	LISTING OF CONSTANTS A1-1
	Frequency Reference Memory Settings (An-XX) A1-1
	Run Operative Settings (bn-XX) A1-2
	System Constants (Sn-XX) A1-3
	Control Constants (Cn-XX) A1-11
	Monitor Displays (Un-XX) A1-15
App. 2	SPECIFICATIONS A2-1
App. 3	GPD 503 CAPACITY (Sn-01) A3-1
App. 4	DIODE AND TRANSISTOR MODULE RESISTANCE TEST A4-1
App. 5	DIMENSIONS A5-1
App. 6	SPARES A6-1
App. 7	DYNAMIC BRAKING CONNECTIONS A7-1

INSTALLATION REFERENCE SHEET

• Drive Information:

Model Number _____
 Specification _____
 Voltage _____
 kW _____
 Number _____
 Location _____
 Drive Rated Amps _____
 Variable Torque – 125% OL _____
 Constant Torque – 150% OL _____
 EPROMs _____
 I/O Boards _____
 V/Hz Pattern _____
 Speed/Torque Regulation _____
 Pulse Generator Input _____
 Thermal Motor Overload
 Protection – Sn-14 _____
 Motor Rated Current – Cn-09 _____

• Motor Nameplate Information:

Full Load Amps _____
 Voltage _____
 Horsepower _____
 Poles _____
 RPM _____
 Service Factor _____
 NEMA Design _____
 Insulation Class _____
 TEFC ___ or TENV ___
 Disconnect at Motor _____
 Single/Multiple Motor _____
 Pulse Generator _____
 Location _____
 Number _____

• Load / Machine:

Torque Requirements as % of
 Full Load Torque:
 Breakaway _____
 Running _____
 Peak _____
 Speed Range _____
 Gear/Pulley Ratio _____
 Speed/Torque Controlled _____
 Accuracy Required _____
 Inertia _____
 Location _____
 Number _____

• Control:

Controlled Variable (Pressure, Flow, Temp,
 Level, etc.) _____
 Sensor _____
 Location _____
 Number _____
 Output _____
 Run/Stop:
 2-Wire ___ or 3-Wire ___ Contro
 Location(s) _____
 Numbers _____
 Speed Reference: 0-10 Vdc ___
 or 4-20 mA ___

• Power Supply:

Circuit Breaker / Amps _____
 Disconnect / Fused _____
 Location _____
 Number _____
 Source _____
 Voltage _____
 Frequency _____
 Quality _____

• Auxiliary Devices:

Reactors
 Input _____
 Output _____
 Filters
 Input _____
 Output _____
 Bypass _____

TROUBLESHOOTING / MAINTENANCE REFERENCE SHEET

• **Fault Code History:**

Date	Fault	Cause	Solution
_____	_____	_____	_____
_____	_____	_____	_____
_____	_____	_____	_____
_____	_____	_____	_____
_____	_____	_____	_____
_____	_____	_____	_____
_____	_____	_____	_____
_____	_____	_____	_____
_____	_____	_____	_____
_____	_____	_____	_____
_____	_____	_____	_____
_____	_____	_____	_____
_____	_____	_____	_____
_____	_____	_____	_____
_____	_____	_____	_____
_____	_____	_____	_____
_____	_____	_____	_____
_____	_____	_____	_____
_____	_____	_____	_____
_____	_____	_____	_____
_____	_____	_____	_____

• **Preventive Maintenance Log:**

Date	Action	Person
_____	_____	_____
_____	_____	_____
_____	_____	_____
_____	_____	_____
_____	_____	_____
_____	_____	_____
_____	_____	_____
_____	_____	_____
_____	_____	_____
_____	_____	_____
_____	_____	_____
_____	_____	_____
_____	_____	_____
_____	_____	_____
_____	_____	_____
_____	_____	_____
_____	_____	_____
_____	_____	_____
_____	_____	_____
_____	_____	_____
_____	_____	_____
_____	_____	_____

Section 1. INSTALLATION

1.1 GENERAL

The GPD 503 is a high performance sine-coded pulse width modulated AC motor drive which generates an adjustable voltage/frequency three phase output for complete speed control of any conventional squirrel cage induction motor. Automatic stall prevention and voltage boost prevents nuisance tripping during load or line side transient conditions. The GPD 503 will not induce any voltage line notching distortion back to the utility line and maintains a displacement power factor of not less than 0.95 throughout its speed range.

When properly installed, operated and maintained, the GPD 503 will provide a lifetime of service. It is mandatory that the person who operates, inspects, or maintains this equipment thoroughly read and understand this manual before proceeding.

This manual primarily describes the GPD 503, but contains basic information for the operator control station as well. For details of the operation of other units in the drive system, refer to their respective manuals.

1.2 RECEIVING

The GPD 503 is thoroughly tested at the factory. After unpacking, verify the part numbers with the purchase order (invoice). Any damages or shortages evident when the equipment is received must be reported immediately to the commercial carrier who transported the equipment. Assistance, if required, is available from your sales representative.

1.3 PHYSICAL INSTALLATION

Location of the GPD 503 is important to achieve proper performance and normal operating life. The unit should be installed in an area where it will be protected from:

- Direct sunlight, rain or moisture.
- Corrosive gases or liquids.
- Vibration, airborne dust or metallic particles.

For effective cooling as well as proper maintenance, a wall mount style GPD 503 must be installed vertically to the ground using four mounting screws. There **MUST** be a **MINIMUM** 6 in. clearance above and below the GPD 503. A **MINIMUM** 2 in. clearance is required on each side on the GPD 503.

A free-standing style GPD 503 must be installed with enough clearance for opening the door of the cabinet; this will ensure sufficient air space for cooling.

1.4 ELECTRICAL INSTALLATION

All basic interconnections (using the Digital Operator) are shown in Figures 1-3 through 1-6.

1.4.1 Main Circuit Input/Output

Complete wiring interconnections for the main circuit according to Tables 1-1 and 1-2, while observing the following:

CAUTION

Use only factory supplied instructions to install dynamic braking resistors. Failure to do so may cause equipment damage or personal injury.

- Use 600 V vinyl-sheathed wire or equivalent. Wire size should be determined considering voltage drop of leads.
- NEVER connect AC main power to output terminals T1 (U), T2 (V), and T3 (W).
- NEVER allow wire leads to contact the GPD 503 enclosure. Short-circuit may result.
- NEVER connect power factor correction capacitors or noise filter to GPD 503 output.
- SIZE OF WIRE MUST BE SUITABLE FOR CLASS I CIRCUITS.
- Use UL listed closed loop connectors or CSA certified ring connectors sized for the selected wire gauge. The connectors are to be installed using the correct crimp tool recommended by the connector manufacturer.

WIRE SIZE		TERMINAL SCREW	CLOSED-LOOP CONNECTOR	CLAMPING TORQUE			
AWG	mm ²			STEEL		COPPER	
				lb-in	N-m	lb-in	N-m
20	0.5	M3.5	1.25 - 3.5	7.8	0.9	7.0	0.8
18	0.75	M4	1.25 - 4	13.0	1.5	10.4	1.2
16	1.25	M4	1.25 - 4	13.0	1.5	10.4	1.2
14	2	M4	2 - 4	13.0	1.5	10.4	1.2
		M5	2 - 5	26.1	20.9	3.1	2.4
12	3.5	M4	3.5 - 4	13.0	1.5	10.4	1.2
		M5	3.5 - 5	26.1	20.9	3.1	2.4
10	5.5	M4	5.5 - 4	13.0	1.5	10.4	1.2
		M5	5.5 - 5	26.1	20.9	3.1	2.4
8	8	M5	8 - 5	26.1	20.9	3.1	2.4
		M6	8 - 6	40.9	34.8	4.8	4.1
6	14	M6	14 - 6	40.9	34.8	4.8	4.1
4	22	M8	22 - 8	100.0	82.6	11.7	10.7
2	38	M8	38 - 8	100.0	82.6	11.7	10.7
		M10	38 - 10	182.6	156.5	21.4	18.4
1/0	60	M10	60 - 10	182.6	156.5	21.4	18.4
3/0	80	M10	80 - 10	182.6	156.5	21.4	18.4
4/0	100	M10	100 - 10	182.6	156.5	21.4	18.4
		M12	100 - 12	313.0	191.3	36.7	23.1
MCM300	150	M12	150 - 12	313.0	191.3	36.7	23.1
MCM400	200	M12	200 - 12	313.0	191.3	36.7	23.1
MCM650	325	M12	325 - 12	313.0	191.3	36.7	23.1

Table 1-1. Wire Sizing For Main Circuit

SECTION A. 230V				
DRIVE MODEL NO.	TERMINAL SYMBOL	TERMINAL SCREW	WIRE SIZE	
			AWG	mm ²
DS305	L1 (R), L2 (S), L3 (T), -, B1/+, B2, T1 (U), T2 (V), T3 (W), G (E)	M4	14 - 10	2 - 5.5
DS302, DS306	L1 (R), L2 (S), L3 (T), -, B1/+, B2, T1 (U), T2 (V), T3 (W)	M4	14 - 10	2 - 5.5
	G (E)	M4	12 - 10	3.5 - 5.5
DS307	L1 (R), L2 (S), L3 (T), -, B1/+, B2, T1 (U), T2 (V), T3 (W), G (E)	M4	10	5.5
DS308, DS309	L1 (R), L2 (S), L3 (T), -, B1/+, B2, T1 (U), T2 (V), T3 (W)	M5	8	8
	G (E)	M5	10	5.5
DS310	L1 (R), L2 (S), L3 (T), B0/-, B1/+, T1 (U), T2 (V), T3 (W)	M6	4	22
	G (E)		8 - 2	8 - 38
	I1 (r), I2 (s)	M4	14 - 10	2 - 5.5
DS311	L1 (R), L2 (S), L3 (T), B0/-, B1/+, T1 (U), T2 (V), T3 (W)	M8	3 - 1/0	30 - 60
	G (E)		8 - 2	8 - 38
	I1 (r), I2 (s)	M4	14 - 10	2 - 5.5
DS322	L1 (R), L2 (S), L3 (T), B0/-, B1/-, B1/+, T1 (U), T2 (V), T3 (W)	M8	2 - 1/0	38 - 60
	G (E)		6 - 2	14 - 38
	I1 (r), I2 (s)	M4	14 - 10	2 - 5.5
DS323	L1 (R), L2 (S), L3 (T), B0/-, B1/+, T1 (U), T2 (V), T3 (W)	M8	1/0	60
	G (E)		6 - 2	14 - 38
	I1 (r), I2 (s)	M4	14 - 10	2 - 5.5
DS2040	L1 (R), L2 (S), L3 (T), -, +1, +3, T1 (U), T2 (V), T3 (W)	M10	2 - 4/0	38 - 100
	G (E)		4 - 2	22 - 38
	I1 (r), I2 (s)	M4	20 - 14	0.5 - 2
GPD503-2L40	L1 (R), L2 (S), L3 (T), - (N), +3 (P3), T1 (U), T2 (V), T3 (W)	M10	2 - 4/0	38 - 100
	G (E)		4 - 2	22 - 38
	I1 (r), I2 (s)	M4	20 - 14	0.5 - 2
DS2050	L1 (R), L2 (S), L3 (T), -, +1, +3, T1 (U), T2 (V), T3 (W)	M10	2 - 4/0	38 - 100
	G (E)		4 - 2	22 - 38
	I1 (r), I2 (s)	M4	20 - 14	0.5 - 2
GPD503-2L50	L1 (R), L2 (S), L3 (T), - (N), +3 (P3), T1 (U), T2 (V), T3 (W)	M10	2 - 4/0	38 - 100
	G (E)		4 - 2	22 - 38
	I1 (r), I2 (s)	M4	20 - 14	0.5 - 2
DS2060	L1 (R), L2 (S), L3 (T), -, +1, +3, T1 (U), T2 (V), T3 (W)	M10	2 - 4/0	38 - 100
	G (E)		4 - 2	22 - 38
	I1 (r), I2 (s)	M4	20 - 14	0.5 - 2
GPD503-2L60	L1 (R), L2 (S), L3 (T), - (N), +3 (P3), T1 (U), T2 (V), T3 (W)	M10	2 - 4/0	38 - 100
	G (E)		4 - 2	22 - 38
	I1 (r), I2 (s)	M4	20 - 14	0.5 - 2
DS2075	L1 (R), L2 (S), L3 (T), -, +1, +3, T1 (U), T2 (V), T3 (W)	M10	2 - 4/0	38 - 100
	G (E)		3 - 2	30 - 38
	I1 (r), I2 (s)	M4	20 - 14	0.5 - 2
GPD503-2L75	L1 (R), L2 (S), L3 (T), - (N), +3 (P3), T1 (U), T2 (V), T3 (W)	M10	2 - 4/0	38 - 100
	G (E)		4 - 2	22 - 38
	I1 (r), I2 (s)	M4	20 - 14	0.5 - 2
DS2100	L1 (R), L2 (S), L3 (T), -, +1, +3, T1 (U), T2 (V), T3 (W)	M12	4/0 - MCM400	100 - 200
	G (E)		1 - 2/0	50 - 67
	I1 (r), I2 (s)	M4	20 - 14	0.5 - 2
GPD503-2L100	L1 (R), L2 (S), L3 (T), - (N), +3 (P3), T1 (U), T2 (V), T3 (W)	M12	4/0 - MCM400	100 - 200
	G (E)		1 - 2/0	50 - 67
	I1 (r), I2 (s)	M4	20 - 14	0.5 - 2

indicates terminal uses a pressure lug.

Table 1-1. Wire Sizing For Main Circuit - Continued

Section B. 460V				
DRIVE MODEL NO.	TERMINAL SYMBOL	TERMINAL SCREW	WIRE SIZE	
			AWG	mm ²
DS313, DS304, DS314	L1 (R), L2 (S), L3 (T), -, B1/+, B2, T1 (U), T2 (V), T3 (W), G (E)	M4	14 - 10	2 - 5.5
DS315	L1 (R), L2 (S), L3 (T), -, B1/+, B2, T1 (U), T2 (V), T3 (W)	M4	14 - 10	2 - 5.5
	G (E)	M5	12 - 10	3.5 - 5.5
DS316	L1 (R), L2 (S), L3 (T), -, B1/+, B2, T1 (U), T2 (V), T3 (W)	M4	12 - 10	3.5 - 5.5
	G (E)	M5	12 - 10	3.5 - 5.5
DS317	L1 (R), L2 (S), L3 (T), -, B1/+, B2, T1 (U), T2 (V), T3 (W)	M4	10	5.5
	G (E)	M5	10	5.5
DS318, DS326	L1 (R), L2 (S), L3 (T), -, B1/+, B2, T1 (U), T2 (V), T3 (W)	M5	8	8
	G (E)		10 - 2	5.5 - 38
	I1 (r), I2 (s)	M4	14 - 10	2 - 5.5
DS325	L1 (R), L2 (S), L3 (T), B0/-, B1/+, T1 (U), T2 (V), T3 (W)	M6	6 - 4	14 - 22
	G (E)		8 - 2	8 - 38
	I1 (r), I2 (s)	M4	14 - 10	2 - 5.5
DS330	L1 (R), L2 (S), L3 (T), B0/-, B1/+, T1 (U), T2 (V), T3 (W)	M6	4	22
	G (E)		8 - 2	8 - 38
	I1 (r), I2 (s)	M4	14 - 10	2 - 5.5
DS340	L1 (R), L2 (S), L3 (T), B0/-, B1/+, T1 (U), T2 (V), T3 (W)	M8	3 - 1/0	30 - 60
	G (E)		8 - 2	8 - 38
	I1 (r), I2 (s)	M4	14 - 10	2 - 5.5
DS350	L1 (R), L2 (S), L3 (T), B0/-, B1/+, T1 (U), T2 (V), T3 (W)	M8	2 - 1/0	38 - 60
	G (E)		6 - 2	14 - 38
	I1 (r), I2 (s)	M4	14 - 10	2 - 5.5
DS360	L1 (R), L2 (S), L3 (T), B0/-, B1/+, T1 (U), T2 (V), T3 (W)	M8	1/0	60
	G (E)		6 - 2	14 - 38
	I1 (r), I2 (s)	M4	14 - 10	2 - 5.5
DS075, DS100	L1 (R), L2 (S), L3 (T), -, B1/+, B2, +3, T1 (U), T2 (V), T3 (W)	M10	2 - 4/0	38 - 100
	G (E)		4 - 2	22 - 38
	I1 (r), I2 200 (s200), I2 400 (s400), x, y	M4	20 - 14	0.5 - 2
GPD503-4L75, GPD503-4L100	L1 (R), L2 (S), L3 (T), - (N), +3 (P3), T1 (U), T2 (V), T3 (W)	M10	2 - 4/0	38 - 100
	G (E)		4 - 2	22 - 38
	I1 (r), I2 200 (s200), I2 400 (s400), x, y	M4	20 - 14	0.5 - 2
DS150	L1 (R), L2 (S), L3 (T), -, B1/+, B2, +3, T1 (U), T2 (V), T3 (W)	M10	2 - 4/0	38 - 100
	G (E)		3 - 2	30 - 38
	I1 (r), I2 200 (s200), I2 400 (s400), x, y	M4	20 - 14	0.5 - 2
GPD503-4L150	L1 (R), L2 (S), L3 (T), -, B1/+, B2, +3, T1 (U), T2 (V), T3 (W)	M10	2 - 4/0	38 - 100
	G (E)		3 - 2	30 - 38
	I1 (r), I2 200 (s200), I2 400 (s400), x, y	M4	20 - 14	0.5 - 2
DS200	L1 (R), L2 (S), L3 (T), -, B1/+, B2, +3, T1 (U), T2 (V), T3 (W)	M12	4/0 - MCM400	100 - 200
	G (E)		1 - 2/0	50 - 67
	I1 (r), I2 200 (s200), I2 400 (s400), x, y	M4	20 - 14	0.5 - 2
GPD503-4L200	L1 (R), L2 (S), L3 (T), - (N), +3 (P3), T1 (U), T2 (V), T3 (W)	M12	4/0 - MCM400	100 - 200
	G (E)		1 - 2/0	50 - 67
	I1 (r), I2 200 (s200), I2 400 (s400), x, y	M4	20 - 14	0.5 - 2
DS250, DS303	L1 (R), L2 (S), L3 (T), -, +1, +3, T1 (U), T2 (V), T3 (W)	M12	MCM650 x 2P	325 x 2P
	G (E)		1/0 - 2/0	54 - 67
	I1 (r), I2 (s), x, y	M4	20 - 14	0.5 - 2
DS400	L1 (R), L2 (S), L3 (T), -, +1, +3, T1 (U), T2 (V), T3 (W)	M12	MCM650 x 2P	325 x 2P
	G (E)		2/0	67
	I1 (r), I2 (s), x, y	M4	20 - 14	0.5 - 2

indicates terminal uses a pressure lug.

Table 1-1. Wire Sizing For Main Circuit - Continued

Section C. 575V				
DRIVE MODEL NO.	TERMINAL SYMBOL	TERMINAL SCREW	WIRE SIZE	
			AWG	mm ²
DS5003, DS5004	L1 (R), L2 (S), L3 (T), -, B1/+, B2, T1 (U), T2 (V), T3 (W)	M4	14 - 10	2 - 5.5
	G (E)	M4	14 - 10	2 - 5.5
DS5006	L1 (R), L2 (S), L3 (T), -, B1/+, B2, T1 (U), T2 (V), T3 (W)	M4	14 - 10	2 - 5.5
	G (E)	M5	14 - 10	2 - 5.5
DS5009, DS5012	L1 (R), L2 (S), L3 (T), -, B1/+, B2, T1 (U), T2 (V), T3 (W)	M4	12 - 10	3.5 - 5.5
	G (E)	M5	12 - 10	3.5 - 5.5
DS5017	L1 (R), L2 (S), L3 (T), -, B1/+, B2, T1 (U), T2 (V), T3 (W)	M5	10 - 8	5.5 - 8
	G (E)		12 - 2	3.5 - 30
	I1 (r), I2 (s)	M4	14 - 10	2 - 5.5
DS5022	L1 (R), L2 (S), L3 (T), -, B1/+, B2, T1 (U), T2 (V), T3 (W)	M6	8 - 6	8 - 14
	G (E)		12 - 2	3.5 - 30
	I1 (r), I2 (s)	M4	14 - 10	2 - 5.5
DS5027	L1 (R), L2 (S), L3 (T), -, B1/+, B2, T1 (U), T2 (V), T3 (W)	M6	8 - 6	8 - 14
	G (E)		10 - 2	5.5 - 30
	I1 (r), I2 (s)	M4	14 - 10	2 - 5.5
DS5032	L1 (R), L2 (S), L3 (T), B0/-, B1/+, B2, T1 (U), T2 (V), T3 (W)	M6	8 - 6	8 - 14
	G (E)		10 - 2	5.5 - 30
	I1 (r), I2 (s)	M4	14 - 10	2 - 5.5
DS5043	L1 (R), L2 (S), L3 (T), B0/-, B1/+, T1 (U), T2 (V), T3 (W)	M8	6 - 1	14 - 38
	G (E)		10 - 2	5.5 - 30
	I1 (r), I2 (s), x, y	M4	14 - 10	2 - 5.5
DS5054	L1 (R), L2 (S), L3 (T), B0/-, B1/+, T1 (U), T2 (V), T3 (W)	M8	4 - 1	22 - 38
	G (E)		8 - 2	8 - 30
	I1 (r), I2 (s), x, y	M4	14 - 10	2 - 5.5
DS5064	L1 (R), L2 (S), L3 (T), B0/-, B1/+, T1 (U), T2 (V), T3 (W)	M8	3 - 1/0	27 - 50
	G (E)		8 - 2	8 - 30
	I1 (r), I2 (s), x, y	M4	14 - 10	2 - 5.5
DS5081	L1 (R), L2 (S), L3 (T), B0/-, B1/+, T1 (U), T2 (V), T3 (W)	M8	1 - 2/0	38 - 60
	G (E)		8 - 2	8 - 30
	I1 (r), I2 (s), x, y	M4	14 - 10	2 - 5.5
DS5112	L1 (R), L2 (S), L3 (T), B0/-, B1/+, T1 (U), T2 (V), T3 (W)	M8	2/0 - 3/0	60 - 80
	G (E)		6 - 2/0	14 - 60
	I1 (r), I2 (s), x, y	M4	14 - 10	2 - 5.5
DS5130	L1 (R), L2 (S), L3 (T), B0/-, B1/+, T1 (U), T2 (V), T3 (W)	M10	3/0 - 300	80 - 150
	G (E)		6 - 2/0	14 - 60
	I1 (r), I2 (s), x, y	M4	14 - 10	2 - 5.5
DS5172	L1 (R), L2 (S), L3 (T), -, B1/+, B2, +3, T1 (U), T2 (V), T3 (W)	M12	3000 - 400	150 - 200
	G (E)		4 - 2/0	22 - 60
	I1 (r), I2 (s), x, y	M4	14 - 10	2 - 5.5
DS5202	L1 (R), L2 (S), L3 (T), -, B1/+, B2, +3, T1 (U), T2 (V), T3 (W)	M12	300 - 400	177 - 200
	G (E)		4 - 2/0	22 - 60
	I1 (r), I2 (s), x, y	M4	14 - 10	2 - 5.5

indicates terminal uses a pressure lug.

Table 1-2. Terminal Functions and Voltages of Main Circuit

SECTION A. 230V				
TERMINAL	FUNCTION			
	1 - 10HP (CT)	15 - 30HP (CT)	40 - 100HP (CT)	
L1 (R) L2 (S) L3 (T)	Three phase Main circuit input power supply 200 / 208 / 220V at 50 Hz; 200 / 208 / 220 / 230V at 60 Hz			
T1 (U) T2 (V) T3 (W)	Three phase AC output to motor 0V to max. input voltage level			
I1 (r) I2 (s)	-----	Power for heat sink fan 200-230 Vac, single phase – two lines from input power		
B0/- B1/+ B2 - [- (N)]** +3 (P3) +1 (P1)	-----	DB Unit terminals * DC bus terminals		-----
	DB Unit terminals (B1/+ & B2) * DC bus terminals (B1/+ & -)	-----	DB Unit terminals (+1 & -) [(+3 & -)]** DC bus terminals (+1 & -) [(+3 & -)]**	
x y	-----	Power supply output for options (220 Vac, 30 VA)		
G (E)	Ground terminal (100 ohms or less)			
SECTION B. 460V				
TERMINAL	FUNCTION			
	1 - 10HP (CT)	15 - 20HP (CT)	25 - 60HP (CT)	75 - 400HP (CT)
L1 (R) L2 (S) L3 (T)	Three phase Main circuit input power supply 380 / 400 / 415 / 460V at 50/60 Hz			
T1 (U) T2 (V) T3 (W)	Three phase AC output to motor 0V to max. input voltage level			
I2 (s) I1 (r) I2 200 (s200) I2 400 (s400)	-----	Power for heat sink fan 230 Vac single phase		----- Power for heat sink fan: I1 to I2 200: 230 Vac I1 to I2 400: 460 Vac
B0/- B1/+ B2 - [- (N)]** +3 (P3) +1 (P1)	-----	DB Unit Terminals * DC bus terminals	-----	
	DB Unit terminals (B1/+ & B2) * DC bus terminals (B1/+ & -)	DB Unit terminals (B1/+ & B2) DC bus terminals (B1/+ & B0/-)	-----	DB Unit Terminals (+1 & -) * [(+3 & -)]** DC bus terminals (+1 & -) [(+3 & -)]**
x y	-----	Power supply output for options (220 Vac, 30 VA)		
G (E)	Ground terminal (100 ohms or less)			

----- indicates that terminals are not present.

* For installation of DB (Dynamic Braking) Units, see Appendix 7.

** indicates terminal marking or connection difference for units with "L" in Model No.

Table 1-2. Terminal Functions and Voltages of Main Circuit - Continued

SECTION C. 575V			
TERMINAL	FUNCTION		
	2-10HP (CT)	15 - 30HP (CT)	40 - 200HP (CT)
L1 (R) L2 (S) L3 (T)	Three phase Main circuit input power supply 500 / 575 / 600V at 50/60 Hz		
T1 (U) T2 (V) T3 (W)	Three phase AC output to motor 0V to max. input voltage level		
I1 (r) I2 (s)	-----	Power for heat sink fan 230 Vac, single phase	
B0/- B1/+ B2 -	----- DB Unit (B1/+ & -) DB Resistor (B1/+ & B2)	DB Unit terminals (B1/+ & B2) DC bus terminals (B1/+ * -)	DB Unit terminals * DC bus terminals -----
+3 (P3) +1 (P1)			
x y	-----	Power supply output for options (220 Vac, 30 VA)	
G (E)	Ground terminal (100 ohms or less)		

----- indicates that terminals are not present.

* For installation of DB (Dynamic Braking) Units, see Appendix 7.

1.4 ELECTRICAL INSTALLATION

Continued

1.4.2 Control Circuit

All basic control circuit (signal) interconnections are shown in the appropriate diagram:

- Interconnections for external two-wire control in combination with the Digital Operator are shown in Figure 1-3 (for 230V or 460V rated drives) and Figure 1-5 (for 575V rated drives).
- Interconnections for external three-wire control in combination with the Digital Operator are shown in Figure 1-4 (for 230V or 460V rated drives) and Figure 1-6 (for 575V rated drives).

Make wiring connections according to Figures 1-1 thru 1-4 and Table 1-3, observing the following :

- Signal Leads : Terminals 1-8, 11-17, and 21-27.
- Control Leads : Terminals 9 & 10 and 18-20.
- Power Leads : Input Terminals L1 (R), L2 (S), and L3 (T), and Output Terminals T1 (U), T2 (V), and T3 (W).
- Use twisted shielded or twisted-pair shielded wire (20-14 AWG (0.5-2mm²) for 1-60HP (CT); 18-14 AWG (0.75-2mm²) for 75-400HP (CT)) for control and signal circuit leads. When using shielded wire, the shield sheath **MUST** be connected at the GPD 503 **ONLY** (terminal 12). The other end should be dressed neatly and left unconnected (floating). See Figure 1-1.
- Lead length should **NOT EXCEED** 164 feet (50 meters). Wire sizes should be determined considering the voltage drop.

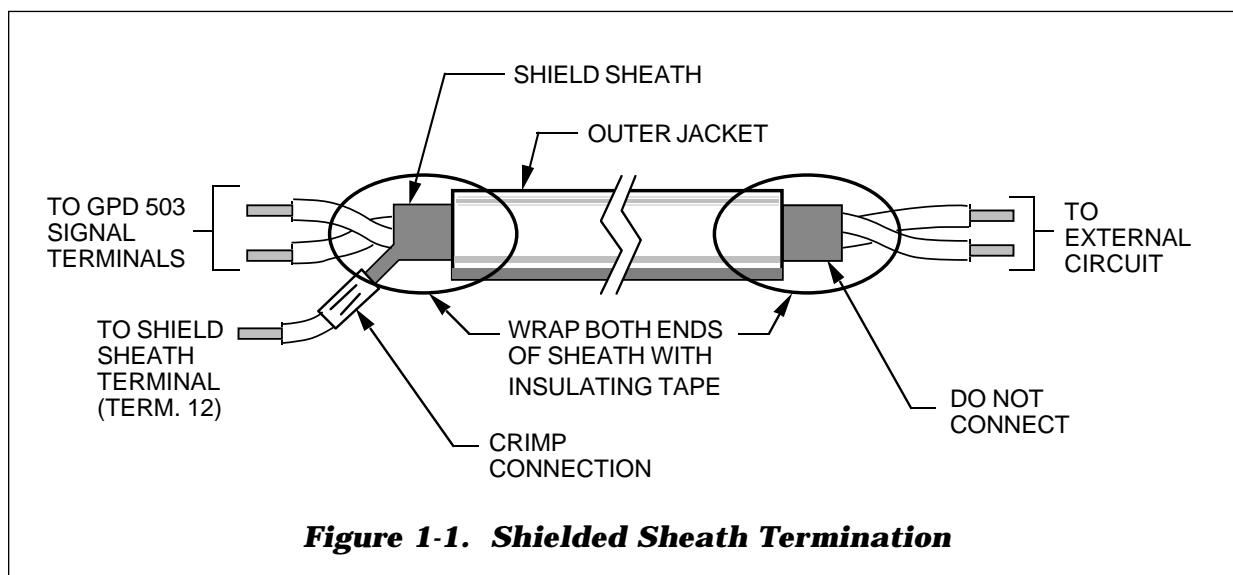

Table 1-3. Terminal Functions and Signals of Control Circuit

TERMINAL	FUNCTIONS	LEVELS
1	2-WIRE CONTROL: Forward Run / Stop signal (See NOTE 1)	Run at closed, stop at open (See NOTE 2)
	3-WIRE CONTROL: Run signal	Run at closed (See NOTE 2)
2	2-WIRE CONTROL: Reverse Run / Stop signal (See NOTE 1)	Run at closed, stop at open (See NOTE 2)
	3-WIRE CONTROL: Stop signal	Stop at open (See NOTE 2)
3	External fault input	Fault at closed (see NOTE 2). When the External Fault input is applied, the GPD 503's Fault relay trips (shutdown) and the motor coasts to a stop. The Digital Operator displays " EF3 " failure.
4	Fault Reset input (external)	Fault Reset at closed (see NOTE 2). The Fault Reset input will reset the Fault relay, if the GPD 503 is in "stopped" condition. Both Forward Run/Stop signal and Reverse Run/Stop signal must be OPEN.
5 - 8	External signal inputs (see NOTE 2); functions as defined by settings of system constants Sn-15 thru Sn-18. See MULTI-FUNCTION INPUT TERMINALS in the PROGRAMMABLE FEATURES section of this manual.	
9, 10	Multi-function contact output. One of 18 functions are available, by setting of system constant Sn-20. (N.O.)	Contact capacity: 250 Vac at 1A or below 30 Vdc at 1A or below
11	Sequence control input common for terminals (1 - 8).	Sequence control input 0 V
12	Connection for shield sheath of signal leads	- - - -
13	Auto frequency reference input	0 to +10V (20K ohms)
14		4-20 mA (250 ohms)
15	Manual frequency reference power supply	+15V (Control power supply for frequency setting: max 20 mA)
16	Multi-function analog input; function of input signal is selected by setting of system constant Sn-19	0 to +10V/100% (20K ohms)
17	Multi-function analog input common	0 V
18	Fault contact output (N.O./N.C.)	Closed at fault
19		Open at fault
20		Common
		Contact capacity: 250 Vac at 1A or below 30 Vdc at 1A or below

Table 1-3. Terminal Functions and Signals of Control Circuit - Continued

TERMINAL	FUNCTIONS	LEVELS	
21	Multi-function analog monitor (+)	Output current or output frequency is selectable	Type of analog signal (operating parameter) to be output is selected by setting of constant bn-13. Monitor output: 0 to +11V; 2 mA maximum
22	Multi-function analog monitor (-)		
25	Multi-function open collector output 1	One of 18 functions are available, by setting of system constants Sn-21 and Sn-22.	Photocoupler insulation output: +48V, 50mA or less
26	Multi-function open collector output 2		
27	Multi-function open collector output common		0V

NOTES:

- When Forward Run and Reverse Run inputs are both closed for more than 500 ms, the Digital Operator flashes “EF” and the motor (if rotating) is decelerated by the GPD 503 to a stop. This stop condition is not stored by the GPD 503 (on Digital Operator, red lamp at **STOP** key does not light); **IF ONE OF THE INPUTS IS OPENED, THE MOTOR WILL IMMEDIATELY START UP AGAIN.**

- Terminals 1-8 source +24 Vdc and operate in a Low = True (ON) configuration when connected to terminal 11.

When using relays for input to terminals 1-8, use relays with highly reliable contacts (for very small current) with a capacity of 30 Vdc or more and rated current of 100mA or higher. When using transistor (open collector) input, use transistors with rated voltage of 35 Vdc or more and rated current of 100mA or more.

1.4.3 Grounding

- The GPD 503 must be solidly grounded using main circuit ground terminal G (E). Ground resistance should be 100 ohms or less. Select lead size suitable for size of terminal screw. Make the length as short as possible.
- NEVER ground the GPD 503 in common with welding machines, motors, or other large-current electrical equipment.
- Where several GPD 503s are used, ground each directly or daisy-chain to the ground pole(s). DO NOT FORM A LOOP WITH THE GROUND LEADS.

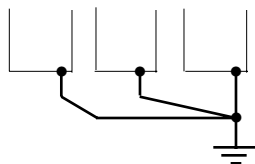

CORRECT

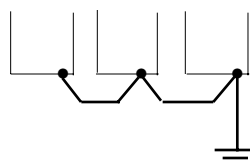

CORRECT

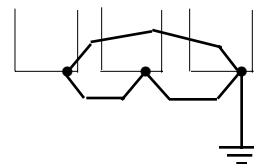

NOT ACCEPTABLE

1.4 ELECTRICAL INSTALLATION

Continued

1.4.4 Auxiliary Input and Output Power Option Devices

Figure 1-2 is a factory guideline for proper wiring practices and relative locations within the electrical path from the line to the load. It does not imply what devices are needed for a particular application, nor does it show what devices were shipped with a particular order. Therefore, disregard those items in the diagram which are not being used in your installation.

Mount all power option devices as close to the drive, and keep electrical connections as short as possible.

DO NOT run input and output wiring in the same conduit.

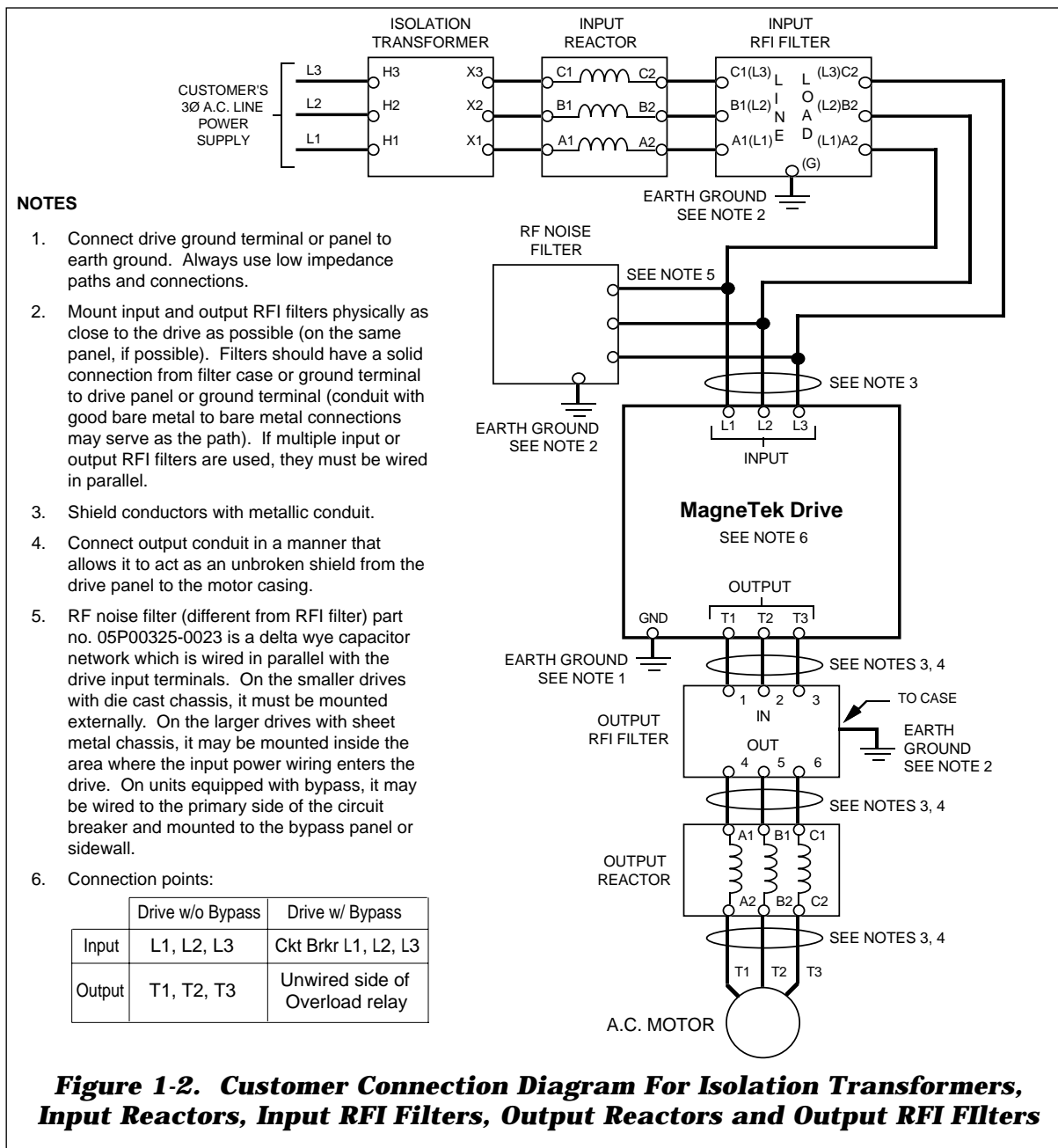

NOTES FOR FIGURE 1-3

- ★ - Indicates components not supplied.
 - - Indicates customer connection terminal. Wire only to terminals shown.
 - () - Indicates alternate terminal marking, i.e., (R) and L1.
 - ▲ - Function labels shown for these terminals are determined by factory settings of System Constants Sn-15 through Sn-18.
 - - Function labels shown for these terminals are determined by factory settings of System Constants Sn-20 through Sn-22.
 - - Function labels shown for these terminals are determined by factory setting of System Constant Sn-05 (X X X X).
 - Function label shown for this terminal is determined by factory setting of System Constant Sn-19.
1. If only a remote Manual Speed pot (1RH) is used, 3SS is not needed; in that case, a jumper must be added between terminals 5 and 11. This jumper will override both the Auto and Digital Operator frequency references, regardless of the programming of Sn-04 X X X X. If you are using a remote speed command or the Digital Operator, DO NOT install this jumper.
 2. The GPD 503 Electronic Thermal Overload function (Sn-17, Cn-09) meets standards set by UL and CSA for motor thermal overload protection. If local code requires separate mechanical overload protection, an overload relay should be installed, interlocked with the GPD 503 as shown. It should be the manual reset type to prevent automatic restart following a motor fault and subsequent contact reclosure after cool down.
 3. Insulated twisted shielded wire is required.
 - 2-conductor #18 GA. (Beldon #8760 or equivalent).
 - 3-conductor #18 GA. (Beldon #8770 or equivalent).Connect shield ONLY AT GPD 503 END. Stub and isolate other end.
 4. Digital Operator is standard on every GPD 503. Remote operators, as shown, may not be required.
 5. Customer to connect terminal G (E) to earth ground.
 6. Wire only one Auto Reference input.
 7. If the Dynamic Braking (DB) option is used, wire per Appendix 7 instructions.

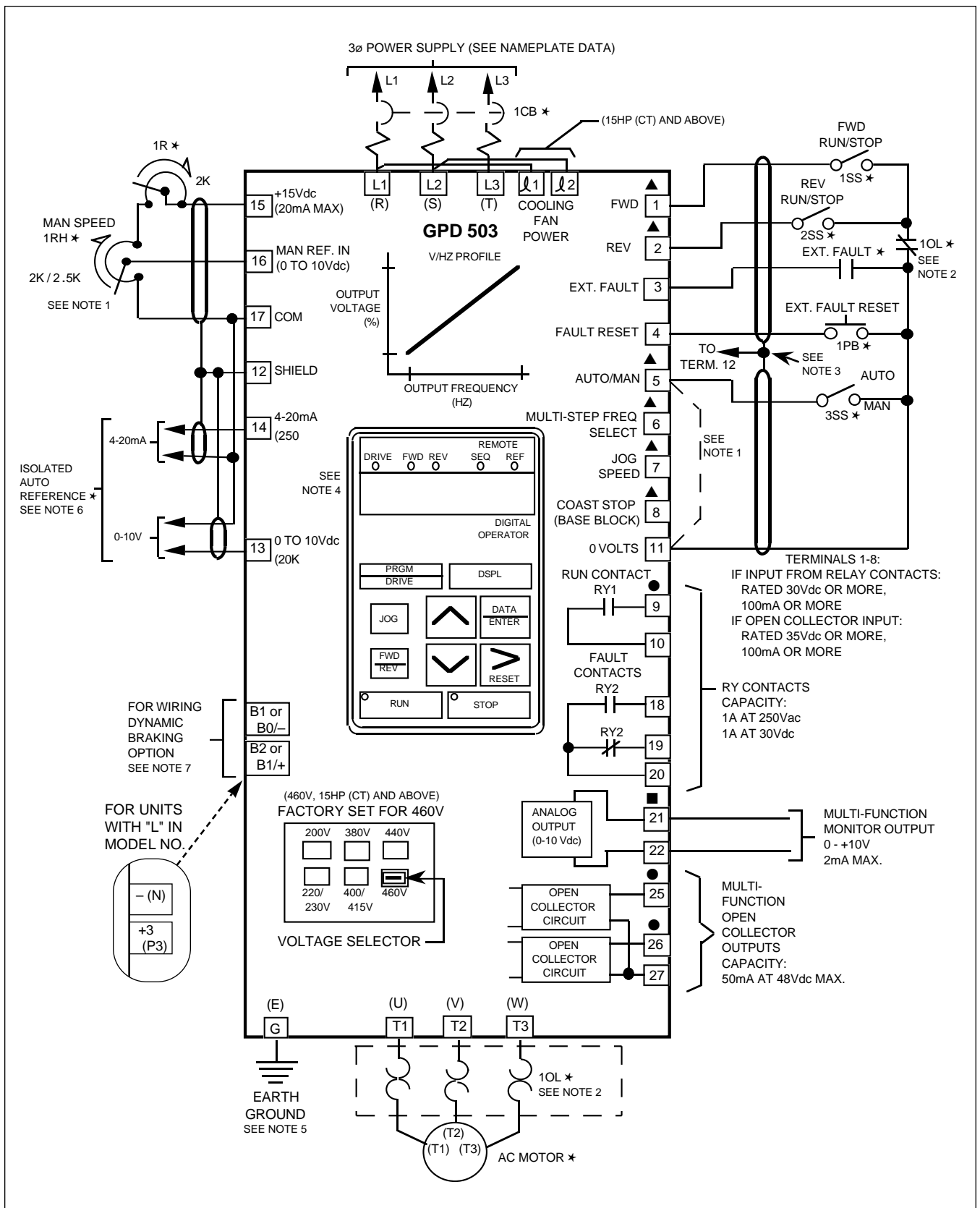

**Figure 1-3. 230V or 460V Interconnections - 2-Wire Control
(with constant Sn-04 set to 0000, Sn-15 set to 03,
Sn-16 set to 04, Sn-17 set to 06, and Sn-18 set to 08)**

NOTES FOR FIGURE 1-4

- ★ - Indicates components not supplied.
 - - Indicates customer connection terminal. Wire only to terminals shown.
 - () - Indicates alternate terminal marking, i.e., (R) and L1.
 - ▲ - Function labels shown for these terminals are determined by 3-Wire Control settings of System Constants Sn-16 through Sn-18: Sn-16 = **03**, Sn-17 = **04**, Sn-18 = **06**.
 - - Function labels shown for these terminals are determined by factory settings of System Constants Sn-20 through Sn-22.
 - - Function labels shown for these terminals are determined by factory setting of System Constant Sn-05 (X X X X).
 - Function label shown for this terminal is determined by factory setting of System Constant Sn-19.
1. If only a remote Manual Speed pot (1RH) is used, 2SS is not needed; in that case, a jumper must be added between terminals 6 and 11. This jumper will override both the Auto and Digital Operator frequency references, regardless of the programming of Sn-04 X X X X. If you are using a remote speed command or the Digital Operator, DO NOT install this jumper.
 2. The GPD 503 Electronic Thermal Overload function (Sn-17, Cn-09) meets standards set by UL and CSA for motor thermal overload protection. If local code requires separate mechanical overload protection, an overload relay should be installed, interlocked with the GPD 503 as shown. It should be the manual reset type to prevent automatic restart following a motor fault and subsequent contact reclosure after cool down.
 3. Insulated twisted shielded wire is required.
 - 2-conductor #18 GA. (Beldon #8760 or equivalent).
 - 3-conductor #18 GA. (Beldon #8770 or equivalent).Connect shield ONLY AT GPD 503 END. Stub and isolate other end.
 4. Digital Operator is standard on every GPD 503. Remote operators, as shown, may not be required.
 5. Customer to connect terminal G (E) to earth ground.
 6. Wire only one Auto Reference input.
 7. If the Dynamic Braking (DB) option is used, wire per Appendix 7 instructions.

CAUTION

Before running, Sn-03 must be set to "0000". Resetting drive constant Sn-03 to "1110" may cause the motor to run in the reverse direction WITHOUT A RUN COMMAND, and possibly result in damage to the equipment or personal injury.

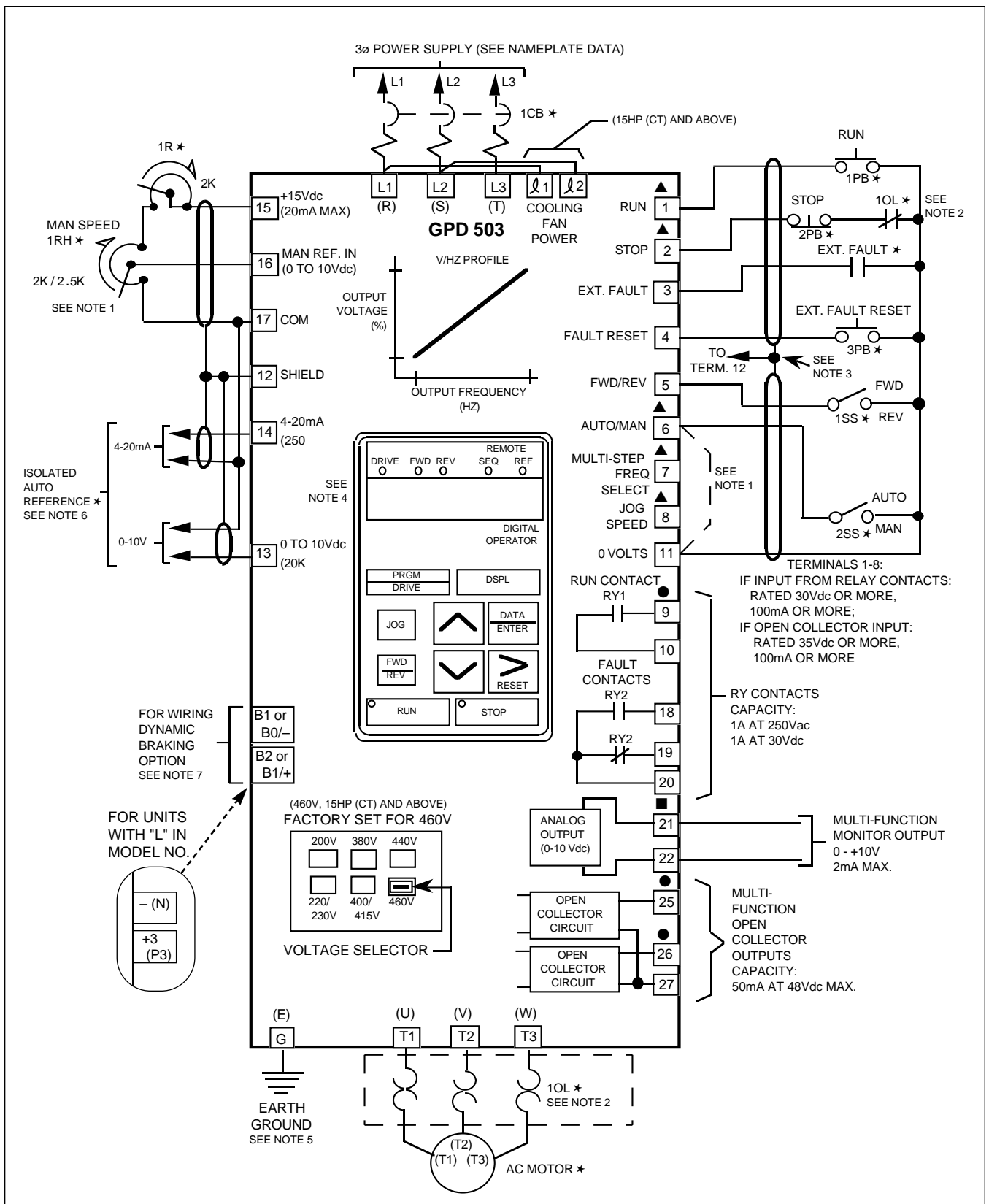

Figure 1-4. 230V or 460V Interconnections - 3-Wire Control (with constant Sn-04 set to 0000, Sn-15 set to 00, Sn-16 set to 03, Sn-17 set to 04, and Sn-18 set to 06)

NOTES FOR FIGURE 1-5

- ★ - Indicates components not supplied.
 - - Indicates customer connection terminal. Wire only to terminals shown.
 - () - Indicates alternate terminal marking, i.e., (R) and L1.
 - ▲ - Function labels shown for these terminals are determined by factory settings of System Constants Sn-15 through Sn-18.
 - - Function labels shown for these terminals are determined by factory settings of System Constants Sn-20 through Sn-22.
 - - Function labels shown for these terminals are determined by factory setting of System Constant Sn-05 (X X X X).
 - Function label shown for this terminal is determined by factory setting of System Constant Sn-19.
1. If only a remote Manual Speed pot (1RH) is used, 3SS is not needed; in that case, a jumper must be added between terminals 5 and 11. This jumper will override both the Auto and Digital Operator frequency references, regardless of the programming of Sn-04 X X X X. If you are using a remote speed command or the Digital Operator, DO NOT install this jumper.
 2. The GPD 503 Electronic Thermal Overload function (Sn-17, Cn-09) meets standards set by UL and CSA for motor thermal overload protection. If local code requires separate mechanical overload protection, an overload relay should be installed, interlocked with the GPD 503 as shown. It should be the manual reset type to prevent automatic restart following a motor fault and subsequent contact reclosure after cool down.
 3. Insulated twisted shielded wire is required.
 - 2-conductor #18 GA. (Beldon #8760 or equivalent).
 - 3-conductor #18 GA. (Beldon #8770 of equivalent).Connect shield ONLY AT GPD 503 END. Stub and isolate other end.
 4. Digital Operator is standard on every GPD 503. Remote operators, as shown, may not be required.
 5. Customer to connect terminal G (E) to earth ground.
 6. Wire only one Auto Reference input.
 7. If the Dynamic Braking (DB) option is used, wire per Appendix 7 instructions.

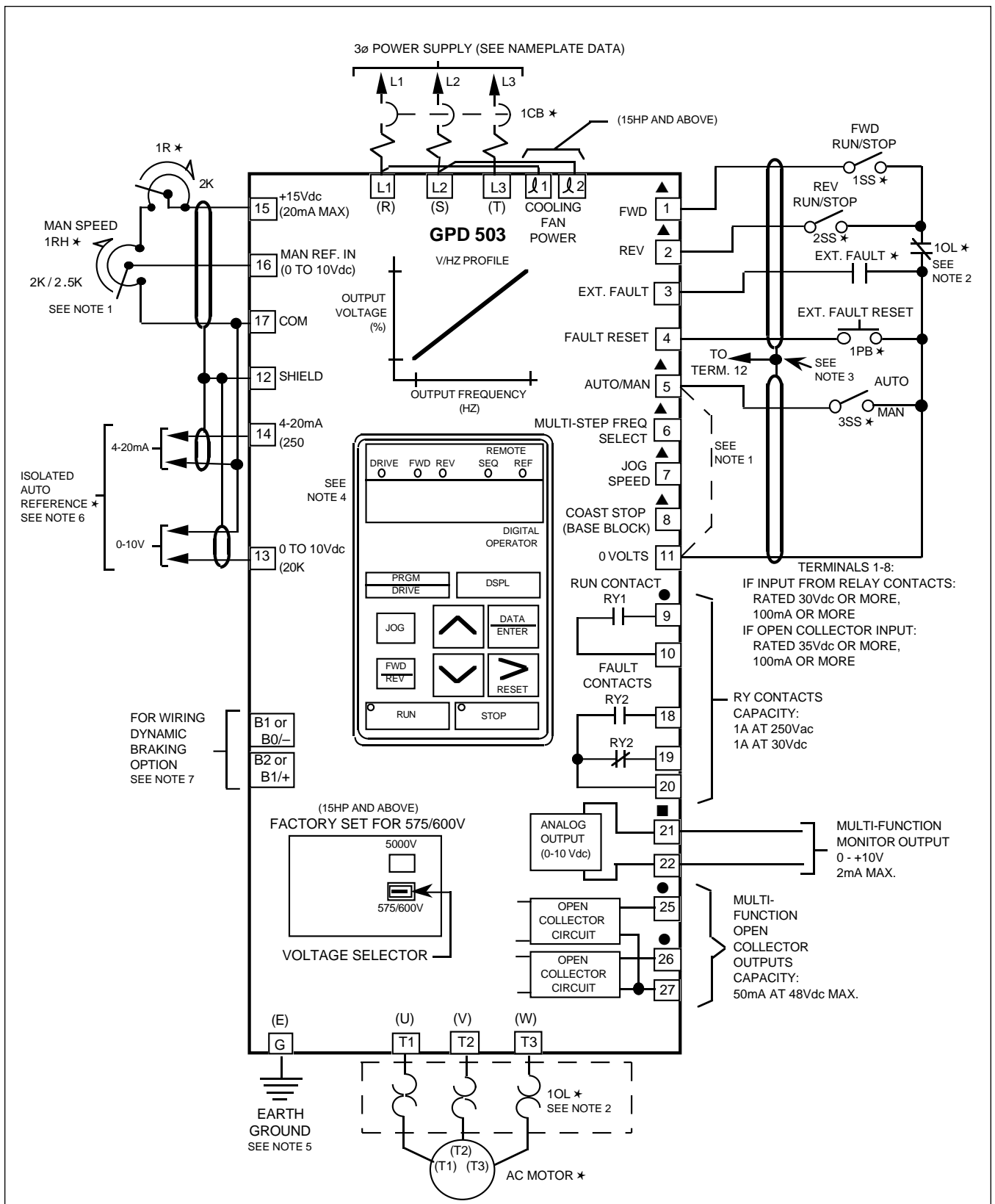

Figure 1-5. 575V Interconnections - 2-Wire Control (with constant Sn-04 set to 0000, Sn-15 set to 03, Sn-16 set to 04, Sn-17 set to 06, and Sn-18 set to 08)

NOTES FOR FIGURE 1-6

- ★ - Indicates components not supplied.
 - - Indicates customer connection terminal. Wire only to terminals shown.
 - () - Indicates alternate terminal marking, i.e., (R) and L1.
 - ▲ - Function labels shown for these terminals are determined by 3-Wire Control settings of System Constants Sn-16 through Sn-18: Sn-16 = **03**, Sn-17 = **04**, Sn-18 = **06**.
 - - Function labels shown for these terminals are determined by factory settings of System Constants Sn-20 through Sn-22.
 - - Function labels shown for these terminals are determined by factory setting of System Constant Sn-05 (X X X X).
 - Function label shown for this terminal is determined by factory setting of System Constant Sn-19.
1. If only a remote Manual Speed pot (1RH) is used, 2SS is not needed; in that case, a jumper must be added between terminals 6 and 11. This jumper will override both the Auto and Digital Operator frequency references, regardless of the programming of Sn-04 X X X X. If you are using a remote speed command or the Digital Operator, DO NOT install this jumper.
 2. The GPD 503 Electronic Thermal Overload function (Sn-17, Cn-09) meets standards set by UL and CSA for motor thermal overload protection. If local code requires separate mechanical overload protection, an overload relay should be installed, interlocked with the GPD 503 as shown. It should be the manual reset type to prevent automatic restart following a motor fault and subsequent contact reclosure after cool down.
 3. Insulated twisted shielded wire is required.
 - 2-conductor #18 GA. (Beldon #8760 or equivalent).
 - 3-conductor #18 GA. (Beldon #8770 or equivalent).Connect shield ONLY AT GPD 503 END. Stub and isolate other end.
 4. Digital Operator is standard on every GPD 503. Remote operators, as shown, may not be required.
 5. Customer to connect terminal G (E) to earth ground.
 6. Wire only one Auto Reference input.
 7. If the Dynamic Braking (DB) option is used, wire per Appendix 7 instructions.

CAUTION

Before running, Sn-03 must be set to "0000". Resetting drive constant Sn-03 to "1110" may cause the motor to run in the reverse direction WITHOUT A RUN COMMAND, and possibly result in damage to the equipment or personal injury.

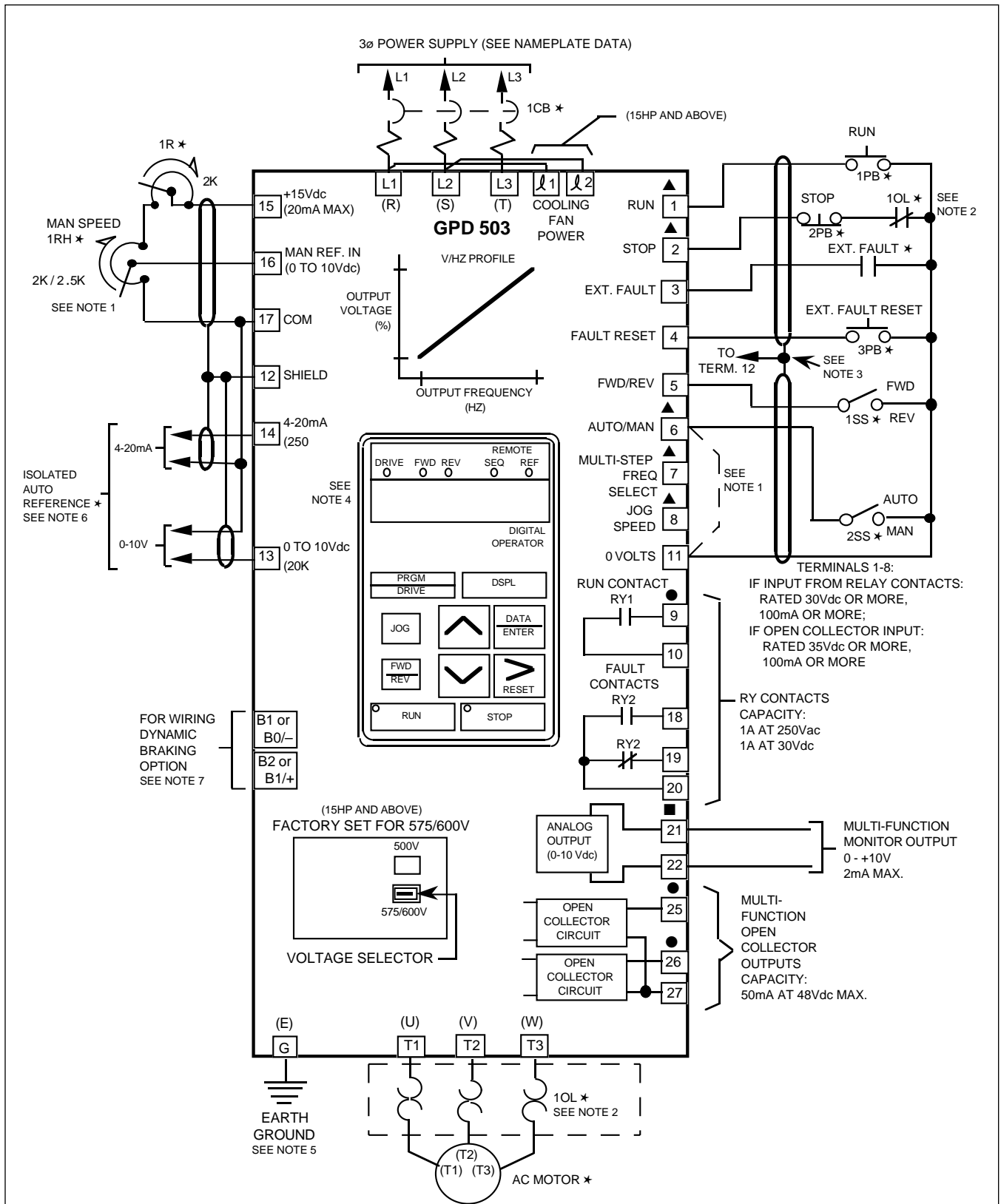

**Figure 1-6. 575V Interconnections - 3-Wire Control
 (with constant Sn-04 set to 0000, Sn-15 set to 00,
 Sn-16 set to 03, Sn-17 set to 04, and Sn-18 set to 06)**

Section 2. PROGRAMMABLE FEATURES

2.1 GENERAL

This section describes features of the GPD 503 which are defined by programmed settings in the various constants in memory. Since most features use more than one constant, the descriptions appear in alphabetical order by the function name. In Table 2-1, the functions are grouped into operational categories. To cross reference a particular constant to the features to which it applies, see the listings in Appendix 1.

Table 2-1. List of Features Defined By Constants

FUNCTION	PARAGRAPH REFERENCE	CONSTANT(S)
<u>SET-UP</u>		
Initialization (Reset), 2-Wire or 3-Wire	2.25	Sn-03
Drive Size (HP), Defining	Table A3-1	Sn-01
Volts/Hertz Patterns, Standard	2.32	Sn-02
Output Voltage Regulator	2.33	Cn-01
Volts/Hertz Pattern, Custom	2.33	Cn-02 thru Cn-08
Thermal Motor Overload Protection	2.30	Sn-14, Cn-09
Display Mode, Choice on Power-Up	2.10	bn-10
Digital Display, Re-scaling	2.9	Cn-20
<u>STARTING</u>		
Accel Time	2.2	bn-01, bn-03
Soft Start Characteristics	2.27	Sn-06
DC Injection Braking at Start	2.8B	Cn-10, -11, -13
<u>STOPPING</u>		
Decel Time	2.2	bn-02, bn-04
DC Injection Braking at Stop	2.8A	Sn-04, Cn-12
<u>REVERSE</u>		
Reverse Run Disabled	Table A1-3	Sn-05
<u>SPEED CONTROL</u>		
Frequency Command, Upper & Lower Limits	2.14	Cn-14, -15
Jog Reference	2.15	An-09
Multi-step Speed	2.24.2	An-01 thru An-08, Sn-04, Sn-15 thru Sn-18, Sn-19
Up/Down Frequency Setting	2.34	Sn-15 thru Sn-18
Speed Reference Selection (Local/Remote)	2.24.1	Sn-04

Table 2-1. List of Features Defined By Constants - Continued

FUNCTION	PARAGRAPH REFERENCE	CONSTANT(S)
<u>RUNNING</u>		
Critical Frequency Rejection	2.7	Cn-16 thru Cn-19
Speed Coincidence	2.23	Cn-21, Cn-22
Carrier Frequency	2.37	Cn-23, -24, -25
Speed Search	2.28	Sn-15, -16, -17
Energy saving	2.11	bn-09
<u>RUNNING IMPROVEMENTS</u>		
Slip Compensation	2.26	bn-08
Torque Compensation	2.31	bn-07
Stall Prevention	2.29	Sn-10, Cn-28, -29, -30
<u>PROTECTIVE FEATURES</u>		
Momentary Power Loss Ride-thru	2.16	Sn-11
Auto Restart	2.5	Cn-36, Sn-11
Auto Reference Loss Detection	2.4	Sn-06
Overtorque Detection	2.22	Sn-07, Cn-26, -27
<u>DRIVE CONTROLS, INPUT</u>		
Multi-function Input Terminals	2.19	Sn-15 thru Sn-18
External Fault Terminals	2.12	Sn-12, Sn-15 thru Sn-18
Multi-function Analog Input	2.18	Sn-19
Auto Reference Characteristics	2.3	Sn-06
Auto Reference Bias and Gain	2.13	bn-05, bn-06
<u>DRIVE OUTPUT</u>		
Multi-function Output Terminals	2.21	Sn-20, -21, -22
Analog Monitor Output	2.20	Sn-05, Sn-09, bn-11
<u>MONITOR DISPLAY</u>		
Monitor Display Selection	2.9	Cn-20
Monitor Display Information	2.17	Un-01 thru Un-10

2.2 ACCEL/DECCEL TIME

- A. **bn-01:** Accel Time 1
- bn-02:** Decel Time 1
- bn-03:** Accel Time 2
- bn-04:** Decel Time 2

Factory setting (each): **10.0** seconds

Range (each): 0.0 to 6000.0 seconds

The GPD 503 incorporates two sets of individually programmable acceleration and deceleration times.

- B. **Sn-15 thru Sn-18:** Multi-function Inputs (Term. 5 thru 8)

Data **07** : Accel/Decel Time Selection

By programming data 07 into one of the multi-function system constants (Sn-15 thru Sn-18), one of the multi-function input terminals (5 thru 8) becomes a time selection input. When the input terminal (i.e. external contact) is open, Time 1 (bn-01/bn-02) is selected. When the input terminal is closed, Time 2 (bn-03/bn-04) is selected.

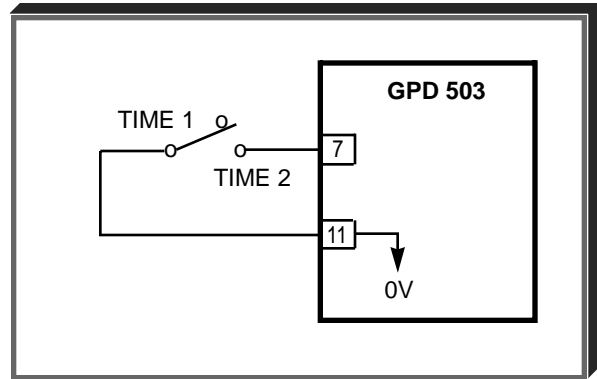

- C. **Sn-19:** Multi-function Analog Input (Term. 16)

Data **06** : Accel/Decel Time Coefficient

The multi-function analog input at terminal 16 may be configured to allow analog control of the Accel/Decel time. The input voltage, in the range of 1 to 10V, determines the coefficient by which the Accel/Decel time is reduced:

$$\frac{\text{Actual Accel/Decel Time}}{\text{Decel Time}} = \frac{\text{Accel/Decel Time}}{\text{Coefficient}}$$

EXAMPLE:

Accel/Decel Time = 10 sec *
Voltage Ref. at Term. 16 = 5V

$$\frac{\text{Actual Accel/Decel Time}}{\text{Decel Time}} = \frac{10 \text{ sec}}{5 \text{ (coefficient)}} = 2 \text{ sec}$$

* bn-01 or bn-03 setting

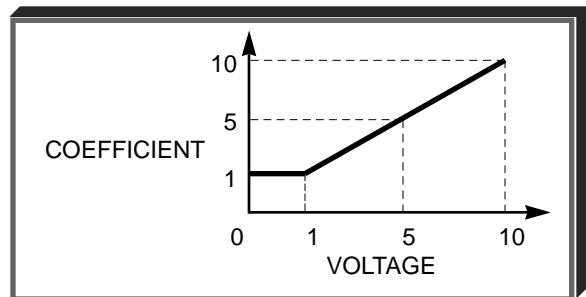
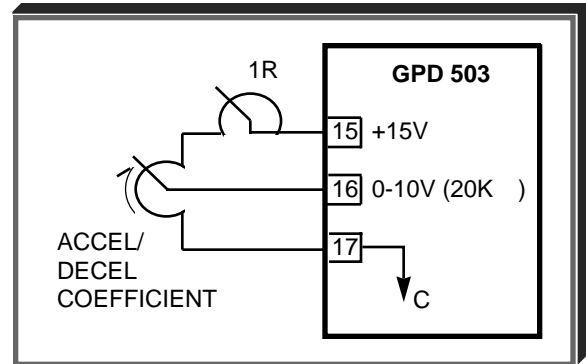

2.3 AUTO REFERENCE CHARACTERISTICS

Sn-06: Operation Mode
Select 3

Digit 3 [X X X X] : Auto Reference
Characteristics

Factory setting: X 0 X X (0 - 100%)

The setting of this digit determines how the frequency command varies with respect to changes in the Auto Reference command input signal.

Auto Reference inputs:
terminals 13 & 17 — 0-10 VDC
terminals 14 & 17 — 4-20 mA

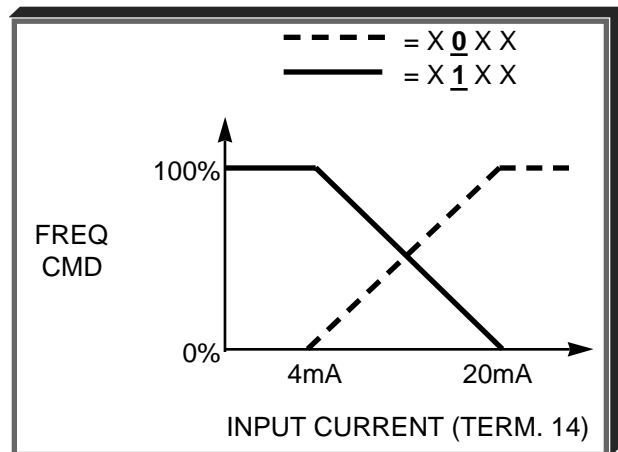
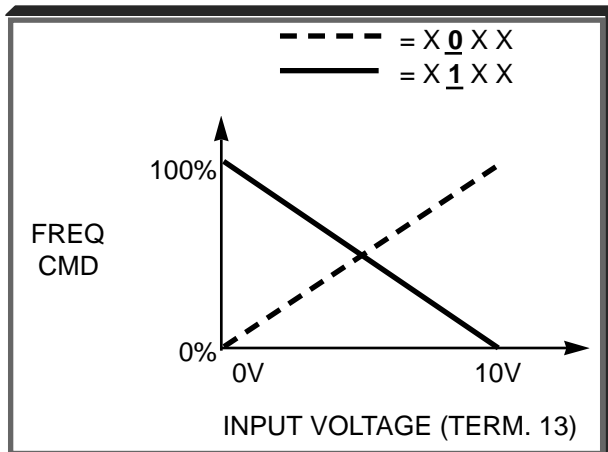
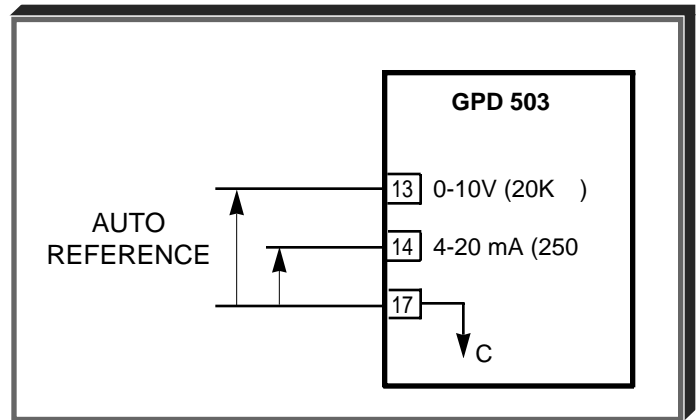

2.4 AUTO REFERENCE - LOSS DETECTION

Sn-06: Operation Mode
Select 3

Digit 4 [**X X X X**] : Auto Reference
Loss Detection

Factory setting: **0 X X X** (disabled)

The reference loss detection function is either enabled or disabled, based on the setting of Sn-06 X X X X. When enabled (1 X X X), the reference loss detection compares the change in reference with respect to time (0.4 seconds). If longer than 0.4 seconds, the GPD 503 will decelerate to the set reference; if shorter than 0.4 seconds, the GPD 503 will continue to operate at 80% of the output frequency. To regain control of output frequency, either exceed the set reference (80% of reference) or initiate a STOP command. (If Auto Reference is less than $F_{max} (Cn-02) \times .05$, then this function is not performed.)

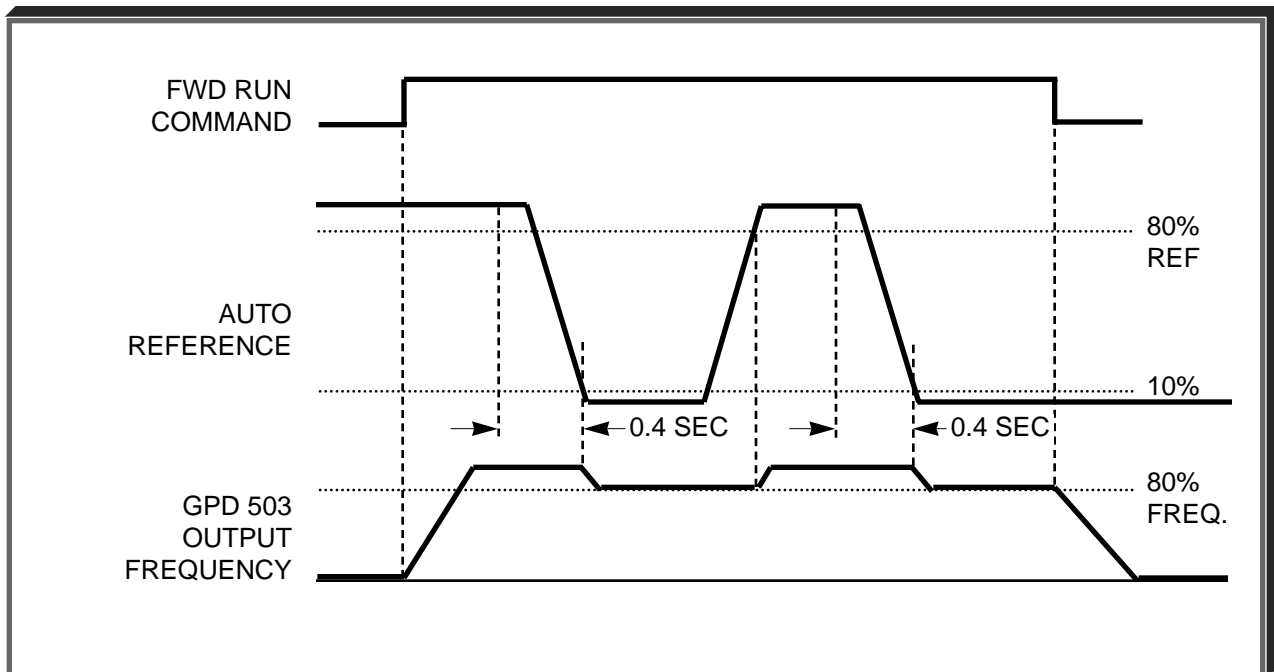

Time Chart

2.5 AUTO-RESTART

A. Cn-36: Number of Auto-Restart Attempts

Factory setting: 00
Range: 00 - 10

When a fault occurs during operation, the GPD 503 can be programmed for an auto-restart operation to automatically reset the fault. Auto-restart operation will use the number of reset attempts set in this constant, up to the maximum of 10. When set to 00, no auto-restarts will be attempted.

- The following faults can be automatically reset:
 - oC: Overcurrent
 - ou: Overvoltage (OV)
 - oL2: Inverter overload
 - oL3: Overtorque
 - oH: Overheat
 - Uu1: Undervoltage (Power UV)
- The following conditions WILL NOT initiate auto-restart:
 - oL1, EF_, FU or CPF__ fault.
 - When OC or UV occurs during deceleration.
 - When Sn-11, digit 3 (X 0 X X) is programmed to stop during momentary power failure. (See para. 2.16, **MOMENTARY POWER LOSS RIDE-THRU**.)
- The number of restart attempts available will be reset to the Cn-36 setting when:
 - 10 minutes has elapsed without a fault occurring.
 - The **RESET** key, or external Fault Reset push button, is pressed.

B. Sn-11: Protective Characteristics Select 2

Digit 2 [X X X X]: Fault Contact Status During Auto-Restart

This digit controls how the fault contact responds to a GPD 503 fault during the auto-restart operation.

- 0: Fault contact will not actuate during auto-restart attempts
- 1: Fault contact actuates during auto-restart attempts

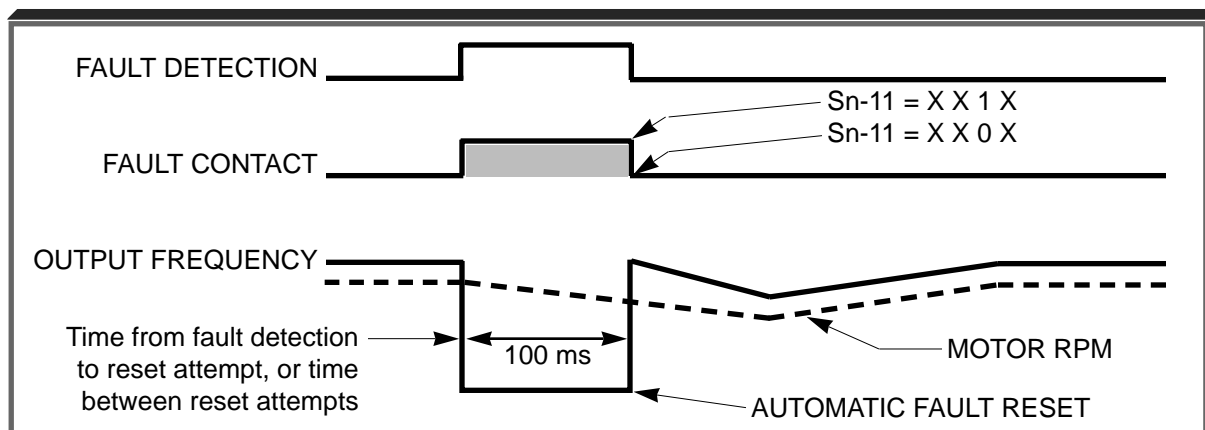

Auto-Restart Operation Timing

2.6 Intentionally Deleted

2.7 CRITICAL FREQUENCY REJECTION

- A. Cn-16:** Prohibited Frequency 1
Cn-17: Prohibited Frequency 2
Cn-18: Prohibited Frequency 3

Factory setting (each): **0.0**

Range (each): 0.0 to 400.0 Hz

These three constants allow programming of up to three prohibited frequency points for eliminating problems with resonant vibration of the motor/machine. This feature does not actually eliminate the selected frequency values, but will accelerate and decelerate the motor through the prohibited bandwidth.

- B. Cn-19:** Prohibited Frequency Deadband

Factory setting: **1.0**

Range: 0.0 to 25.5 Hz

This constant determines the width of the deadband around each selected prohibited frequency point. The factory setting is **1.0**, which establishes a deadband of ± 1.0 Hz.

EXAMPLE:

Vibration encountered between 30.0 and 36.0 Hz.

SOLUTION: Set Cn-16 to **33.0**. This is the center of the problem frequency band.

Set Cn-19 to **3.0**. This will cause the GPD 503 to reject all frequency command values between 30.0 and 36.0 Hz.

A frequency command in the deadband will be converted to the bottom value of the deadband, e.g. a command of 33 Hz would result in a run frequency of 30 Hz.

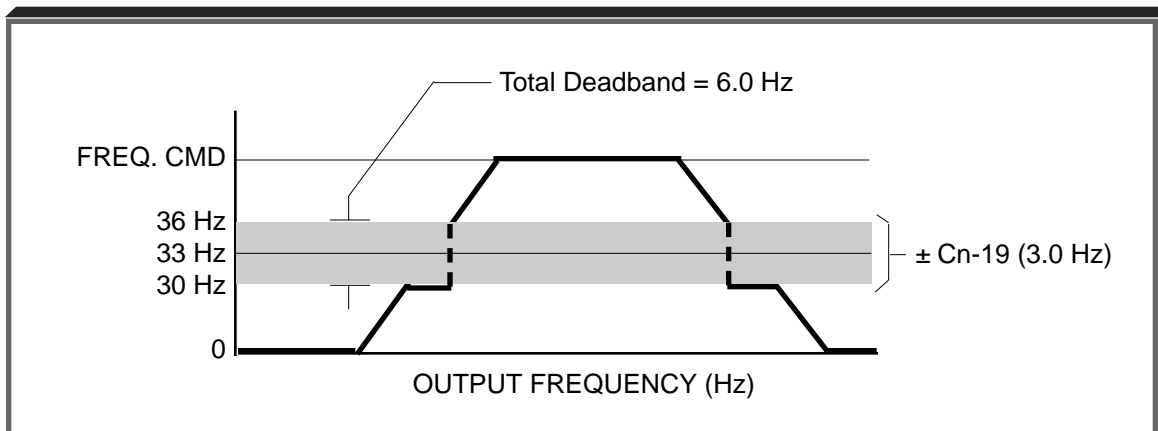

2.8 DC INJECTION BRAKING

A. Sn-04: Operation Mode Select 1

Digits 3 & 4 [**X X X X**] : Motor Stopping Method Selection

Factory setting: **00XX**

Cn-12: DC Injection Time at Stop

Factory setting: **0.0** sec

Range: 0.0 - 25.5 sec

When full range DC injection braking stop is enabled (Sn-04 = **10XX**), DC injection braking is used to stop a motor more quickly than normal coast to stop, without the need for braking resistors. When a STOP command is issued, there is a 0.5 second time delay to apply DC to two phases of the motor's stator winding. Then DC injection current is applied. The duration of DC braking is a time period proportional to Cn-12 (at 10% output frequency) and the level of output frequency at the time the STOP command is issued.

Braking torque is 50-70% of full load motor torque.

EXAMPLE:

Cn-12 = 0.5 sec (at 10% output)

Braking time at Fmax (100% output frequency) = $10 \times 0.5 = 5$ sec

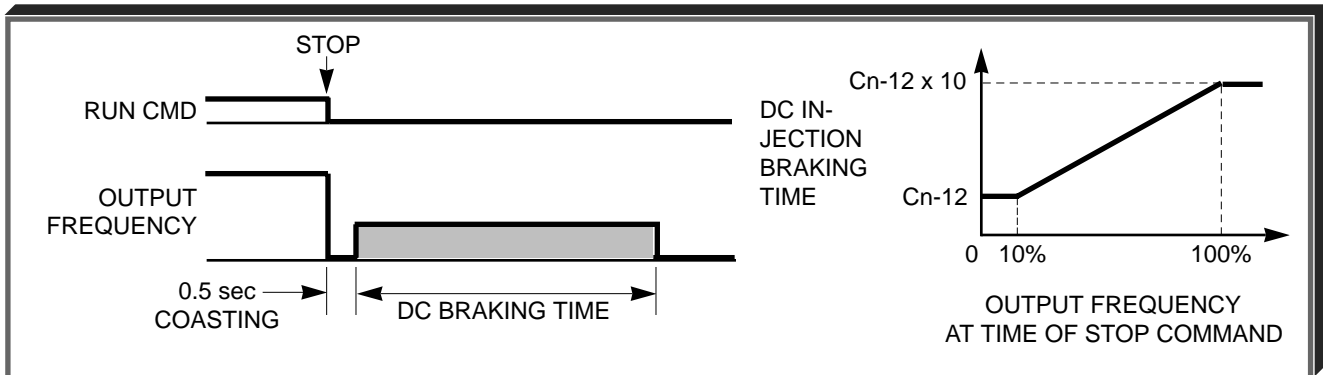

Full Range DC Injection Braking Stop Sequence

2.8 DC INJECTION BRAKING

Continued

B. Cn-10: DC Inj. Braking Start Frequency

Range: 0.0 to 10.0 Hz

Cn-11: DC Inj. Braking Current (% of Drive Rated Current)

Factory setting: **50 %**

Range: 0 to 100 %

Cn-13: DC Injection Time at Start

Factory setting: **0.5 sec**

Range: 0.0 to 25.5 sec

DC injection can be used to stop a motor whose rotational direction is uncertain at start-up. For this operation, application of DC injection braking current is controlled by a multi-function input (see paragraph 2.8.D).

With ramp to stop enabled (Sn-04 = **00XX**), after a STOP command is received the GPD 503 controls motor deceleration according to the Decel Time setting, until output frequency reaches the DC Injection Braking Start Frequency (Cn-10 setting). Then the GPD 503 output is turned off and DC injection current is applied to the motor. The effective DC injection time and current should be set to provide adequate stopping without excessive motor heating. The DC injection voltage is determined by the DC injection braking current and motor impedance.

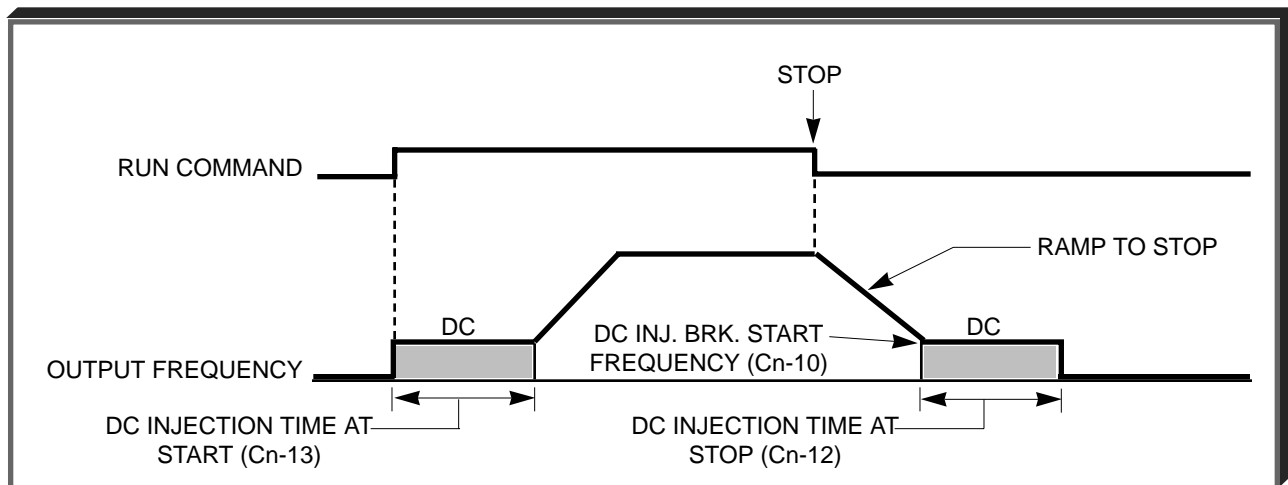

DC Braking Sequence

2.8 DC INJECTION BRAKING

Continued

C. Sn-19: Multi-function Analog Input (Term. 16)

Data 07 : DC Injection Braking Current Adjust

The multi-function analog input at terminal 16 may be configured to allow analog control of the amount of DC injection braking current (from 0% to 100% of the current level set in Cn-11), which directly controls the amount of DC injection voltage applied to the motor.

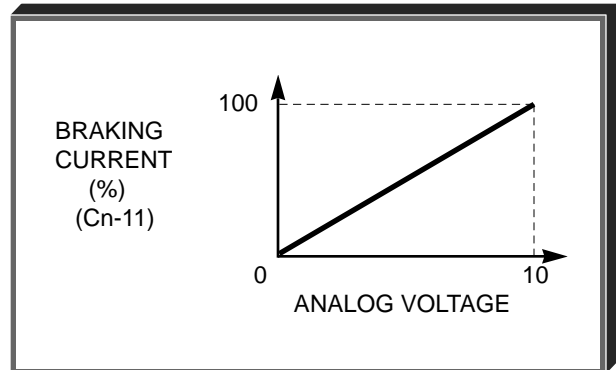
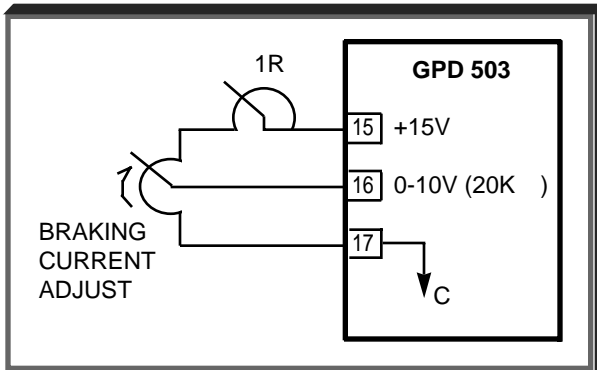

D. Sn-15 thru Sn-18: Multi-function Inputs (Term. 5 thru 8)

Data 60 : DC Injection Braking Command

Any multi-function input terminal can be utilized to control DC injection braking. When used, DC injection current will be applied until the input is removed, provided that the GPD 503 output frequency is *below* the DC Braking Start Frequency (Cn-10).

EXAMPLE:

Sn-18 = 60

Contact input at Terminal 8 is the DC Injection Braking Command

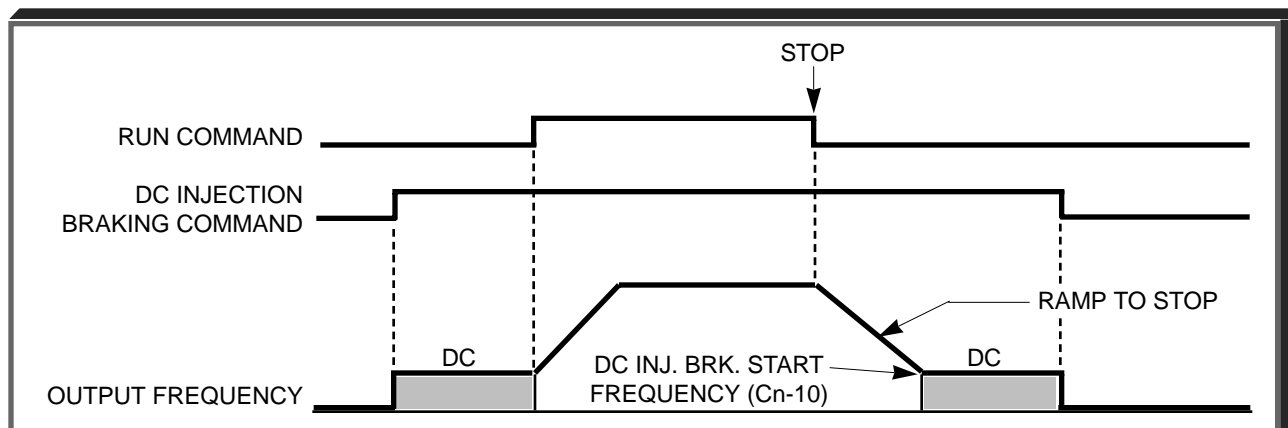
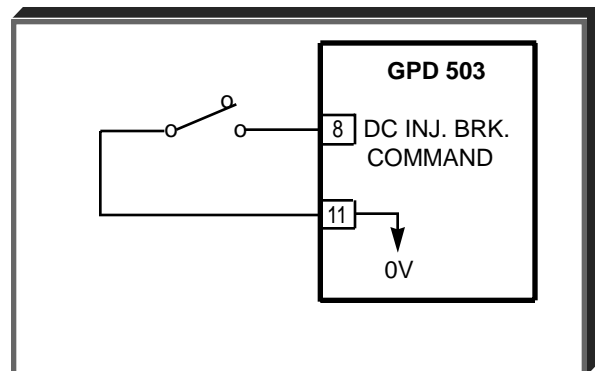

DC Braking Sequence

2.9 DIGITAL DISPLAY SELECTION

Cn-20: Operator Display Mode
Reference and Indication

Factory setting: **0**

Range: 0 to 39999

This constant designates what Drive parameter will be displayed on the Digital Operator when the GPD 503 is in the Drive mode. It will be displayed where "OUTPUT FREQUENCY" was previously displayed.

DATA	PARAMETER DISPLAY
0 (factory setting)	Output frequency, in increments of 0.1 Hz.
1	Same as 0
2 to 39 (no. of motor poles)	Motor synchronous speed ($N_S = \frac{120F}{P}$) in increments of 1 RPM (39999 max). NOTE: When motor synchronous speed exceeds 39999 RPM, display holds at 39999 .
00040 to 39999	Line speed or other parameter. Setting must be 5 digits. <div style="text-align: center;"> $\begin{array}{c} \text{X X X X X} \\ \hline \end{array}$ </div> <div style="margin-left: 100px;"> <p>— Parameter value at maximum frequency (include leading zeroes if necessary)</p> <p>— Location of decimal point: 0 = X X X X 1 = X X X . X 2 = X X . X X 3 = X . X X X (See CAUTION on next page)</p> </div> <p>EXAMPLE:</p> <p>To display Line Speed, based on 54.32 FPM at 60 Hz: Cn-20 setting = 25432</p>

2.11 ENERGY SAVING OPERATION

bn-09: Energy Saving Gain

Factory setting: **80 %**

Range: 0 to 200 %

This constant sets, in increments of 1%, the level to which the output voltage is reduced during the energy-saving operation.

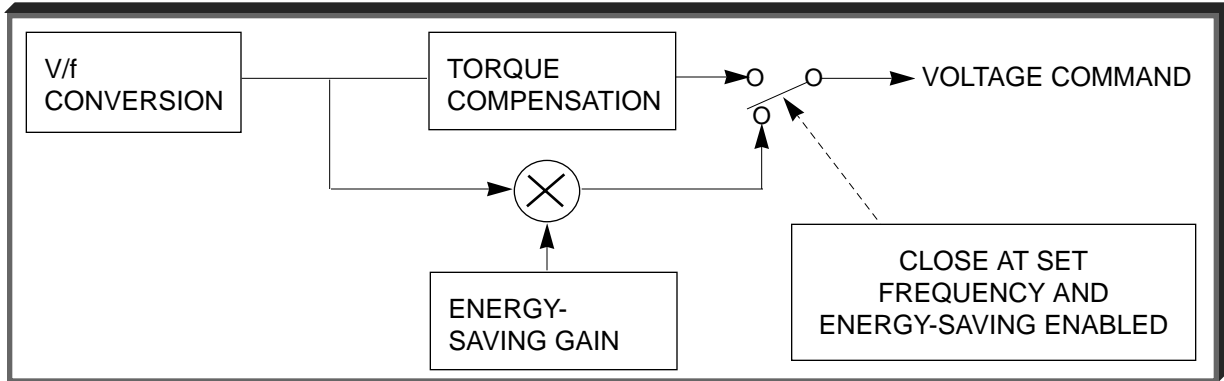

Output Voltage During Energy-Saving Operation

Sn-15 thru Sn-18: Multi-function Inputs (Term. 5 thru 8)

Data 63: Energy Saving Operation

A multi-function input may be utilized to command energy saving operation.

When the external Energy-Saving Operation command is closed at set frequency, the energy-saving operation shown below is enabled. In the energy saving operation, the output voltage is the value of the energy saving gain (bn-09; factory set at 80%) multiplied by the V constants defined by Cn-03, -06 and -08.

NOTE

If energy saving operation is enabled before accel time is complete, output V/Hz is not affected until set frequency is reached; then output voltage is reduced by energy-saving gain (bn-09) setting.

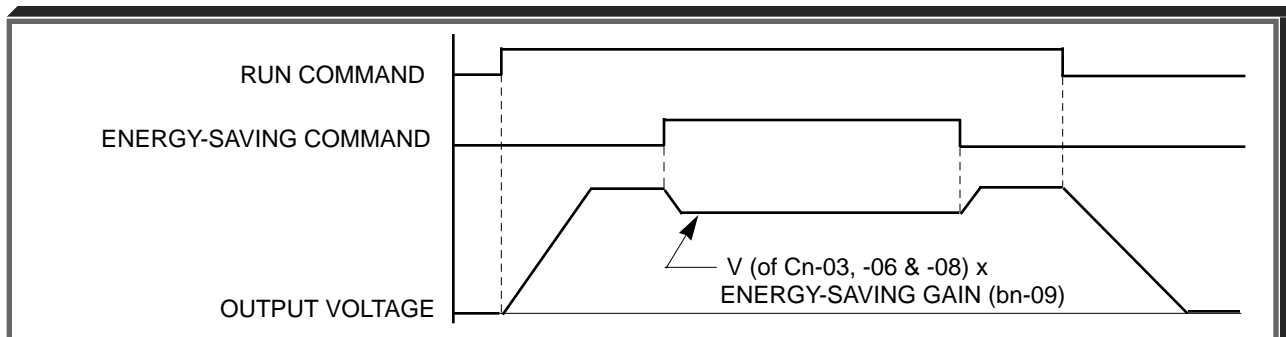
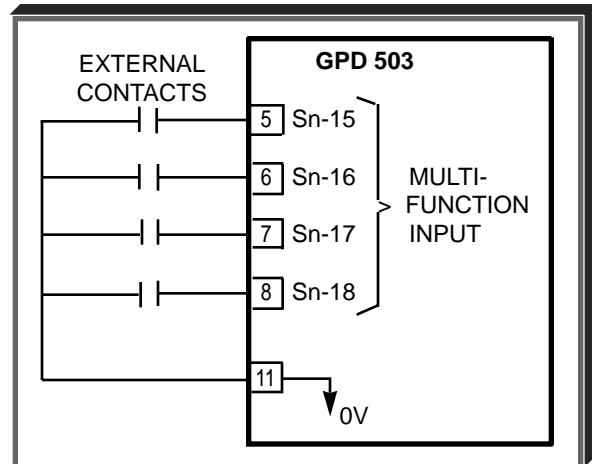

Energy-Saving Run Timing

2.12 EXTERNAL FAULT INPUTS

A. Sn-12: External Fault Signal Input (Terminal 3)

Factory setting: **0100**

This constant determines how the GPD 503 responds to an external fault contact input on terminal 3. The chart below lists the possible settings, and indicates how the GPD 503 will interpret the input signal.

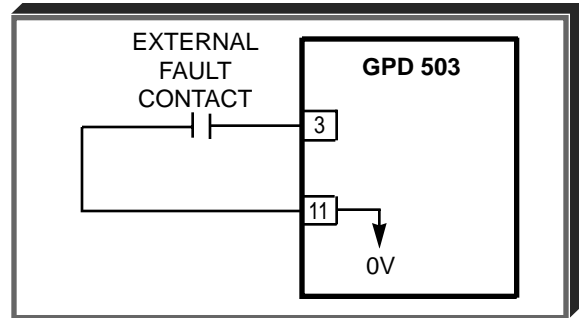

Sn-12 Data	Term. 3 (Note 1)		Always Detected	During Operation	Mode (Note 2)			
	N.O.	N.C.			0	1	2	3
0000	X		X		X			
0001		X	X		X			
0010	X			X	X			
0011		X		X	X			
0100 (Factory Set)	X		X			X		
0101		X	X			X		
0110	X			X		X		
0111		X		X		X		
1000	X		X				X	
1001		X	X				X	
1010	X			X			X	
1011		X		X			X	
1100	X		X					X
1101		X	X					X
1110	X			X				X
1111		X		X				X

NOTES

1. N.O. = normally open contact; N.C. = normally closed contact.
2. Mode 0 = Ramp to Stop (bn-02); Mode 1 = Coast to Stop; Mode 2 = Emergency Stop (bn-04); Mode 3 = Continue operation (minor fault).

2.12 EXTERNAL FAULT INPUTS

Continued

B. Sn-15 thru Sn-18: Multi-function Inputs (Term. 5 thru 8)

Data **20 - 2F**: External Fault 1 (terminal 5)
 Data **30 - 3F**: External Fault 2 (terminal 6)
 Data **40 - 4F**: External Fault 3 (terminal 7)
 Data **50 - 5F**: External Fault 4 (terminal 8)

The multi-function input terminals can be used to monitor external fault contacts. When the External Fault 1-4 signals are inputted, **EF5** to **EF8** are displayed on the Digital Operator (steady for a major fault situation, blinking for a minor fault situation). The second digit of the Sn-15 thru Sn-18 setting is entered as a hexadecimal value; when converted to its binary equivalent, it defines what type of external fault contact is used and how the GPD 503 will react to the fault input.

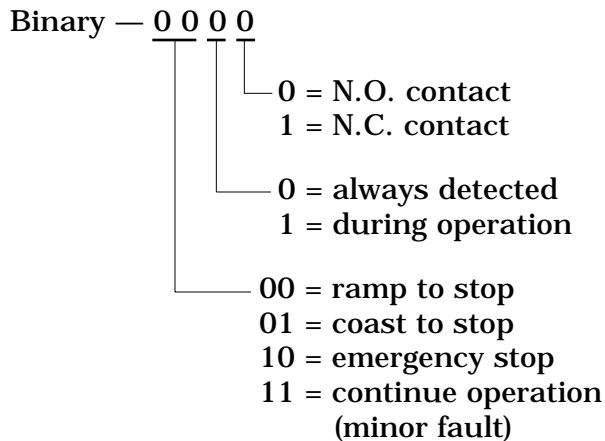

EXAMPLE:

To program External Fault 1 (terminal 5) for a N.C. contact, always detected, and GPD 503 to continue operation, solve for X:

Sn-15 data = **2X**

X = 1 1 0 1

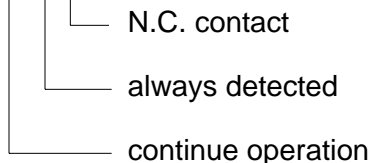

= 1 1 0 1 (binary) = D (hex)

Sn-15 data = **2d**

For the same type of input at External Fault 2 (terminal 6):

Sn-16 data = **3d**

BINARY TO HEX CONVERSION	
BINARY	HEX
0 0 0 0	0
0 0 0 1	1
0 0 1 0	2
0 0 1 1	3
0 1 0 0	4
0 1 0 1	5
0 1 1 0	6
0 1 1 1	7
1 0 0 0	8
1 0 0 1	9
1 0 1 0	A
1 0 1 1	B *
1 1 0 0	C
1 1 0 1	D **
1 1 1 0	E
1 1 1 1	F

* Appears as " **b** " on Digital Operator.

** Appears as " **d** " on Digital Operator.

2.13 FREQUENCY (AUTO) COMMAND BIAS/GAIN

bn-05: Frequency Command Gain

Factory setting: **100.0** %

Range: 0.0 to 1000.0 %

Sets the auto-speed frequency command gain, in increments of 0.1%.

bn-06: Frequency Command Bias

Factory setting: **0** %

Range: -100 to 100 %

Sets the auto-speed frequency command bias, in increments of 1%.

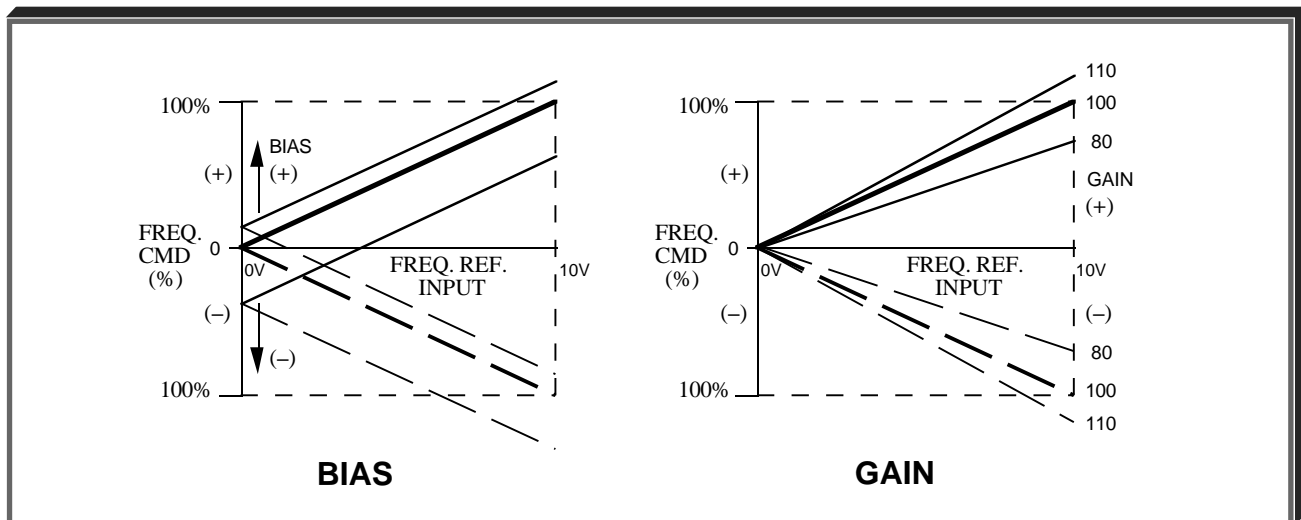

ADJUSTMENT PROCEDURE:

- A. For 0-10 Vdc input (term. 13)
 1. With no input, adjust Bias (bn-06 setting) until an output of 0.00 Hz is obtained.
 2. With full scale input, adjust Gain (bn-05 setting) until an output of 60.00 Hz (or other desired max. output frequency) is obtained.
- B. For 4-20mA input (term. 14)
 1. With 4mA input, adjust Bias (bn-06 setting) until an output of 0.00 Hz is obtained.
 2. With 20mA input, adjust Gain (bn-05 setting) until an output of 60.00 Hz (or other desired max. output frequency) is obtained.

NOTE

Follow the same adjustment procedure for other desired frequency setpoints.

2.14 FREQUENCY COMMAND UPPER & LOWER LIMITS

Cn-14: Frequency Command Upper Limit

Factory setting: **100** %

Range: 0 to 109 %

Cn-15: Frequency Command Lower Limit

Factory setting: **0** %

Range: 0 to 109 %

These two constants set the range for the frequency command signal. Each is set, in increments of 1%, as a percentage of maximum frequency (Fmax) as established by either the selected standard V/f pattern or custom V/f pattern.

NOTE: All references are affected by the upper and lower limit points.

EXAMPLE:

Cn-02 = **60** Hz (100%)

Cn-14 = **80** % = 48Hz – Max. speed

Cn-15 = **10** % = 6Hz – Min. speed

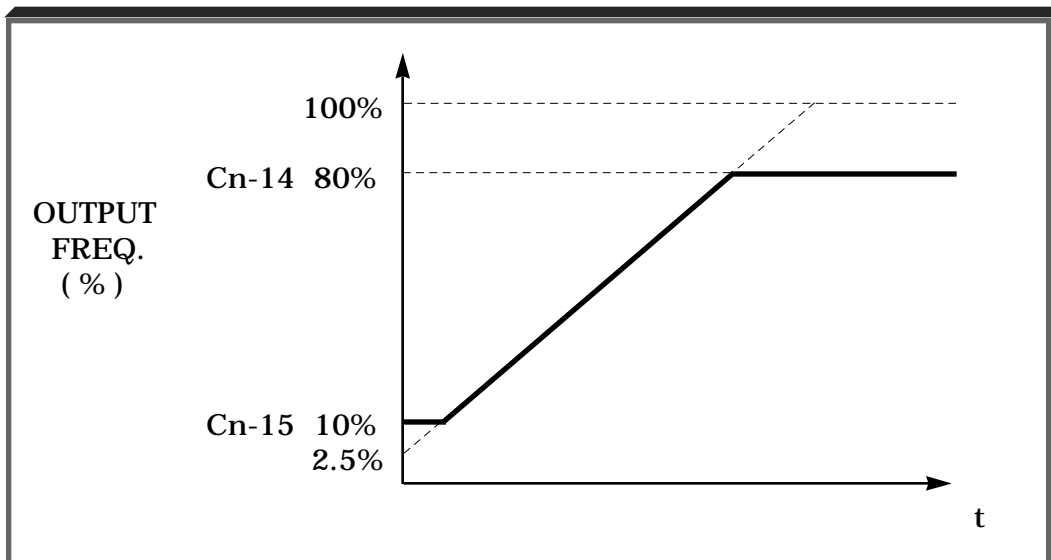

2.15 JOG REFERENCE

An-09: Jog Reference

Factory setting: **6.00** Hz

Range: 0.00 to 400.00 Hz

When jog operation is selected (either by the Digital Operator **JOG** key, or by external Jog and Run signals), the GPD 503 output will ramp to the output level set by this constant.

When the Digital Operator is used, Jog can only be initiated from the stopped condition. When the drive is running, the **JOG** key will have no effect on GPD 503 output.

When an external Jog signal is present, it will override the existing operation mode and the GPD 503 will ramp to the level set by this constant.

EXAMPLES:

OPERATION FROM DIGITAL OPERATOR

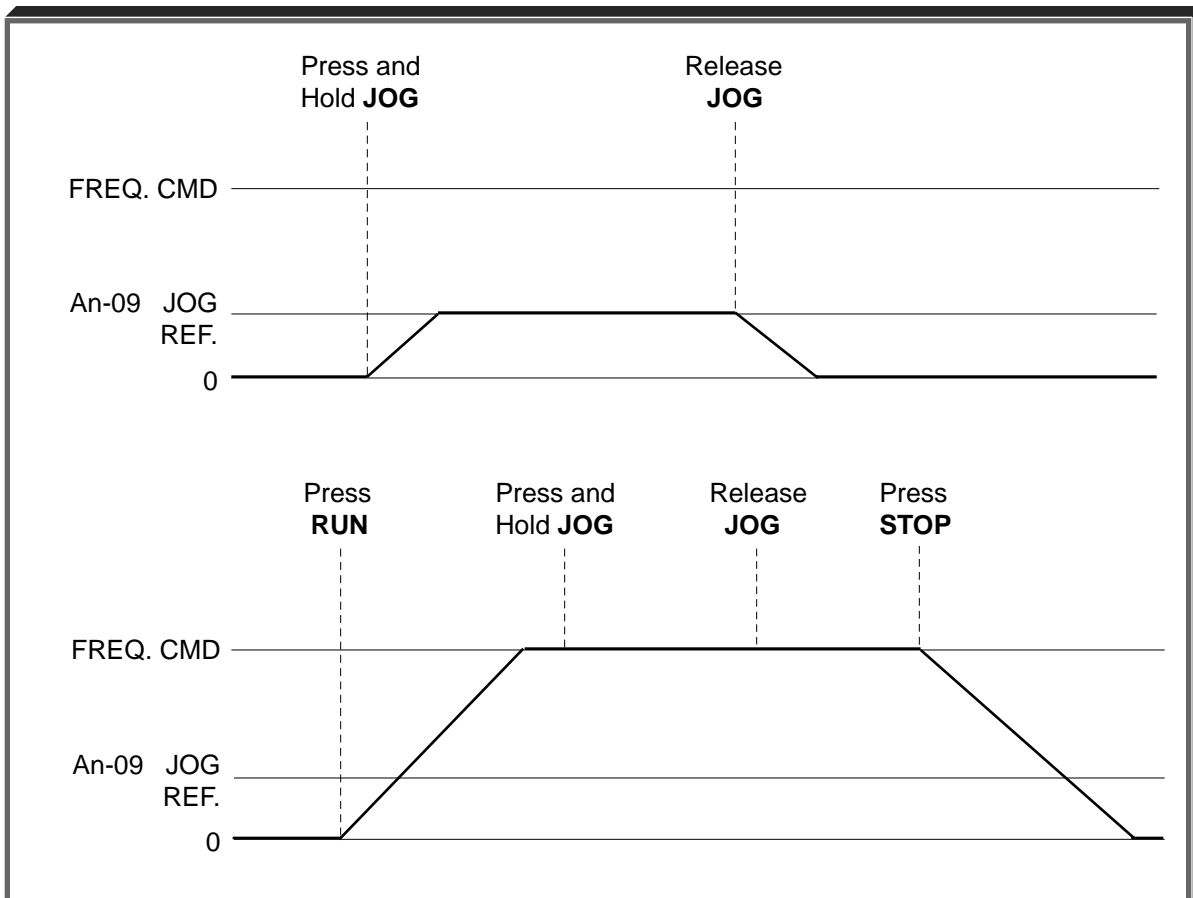

2.15 JOG REFERENCE

Continued

EXAMPLES: (Continued)

OPERATION BY REMOTE SIGNAL INPUT (RUN & JOG)

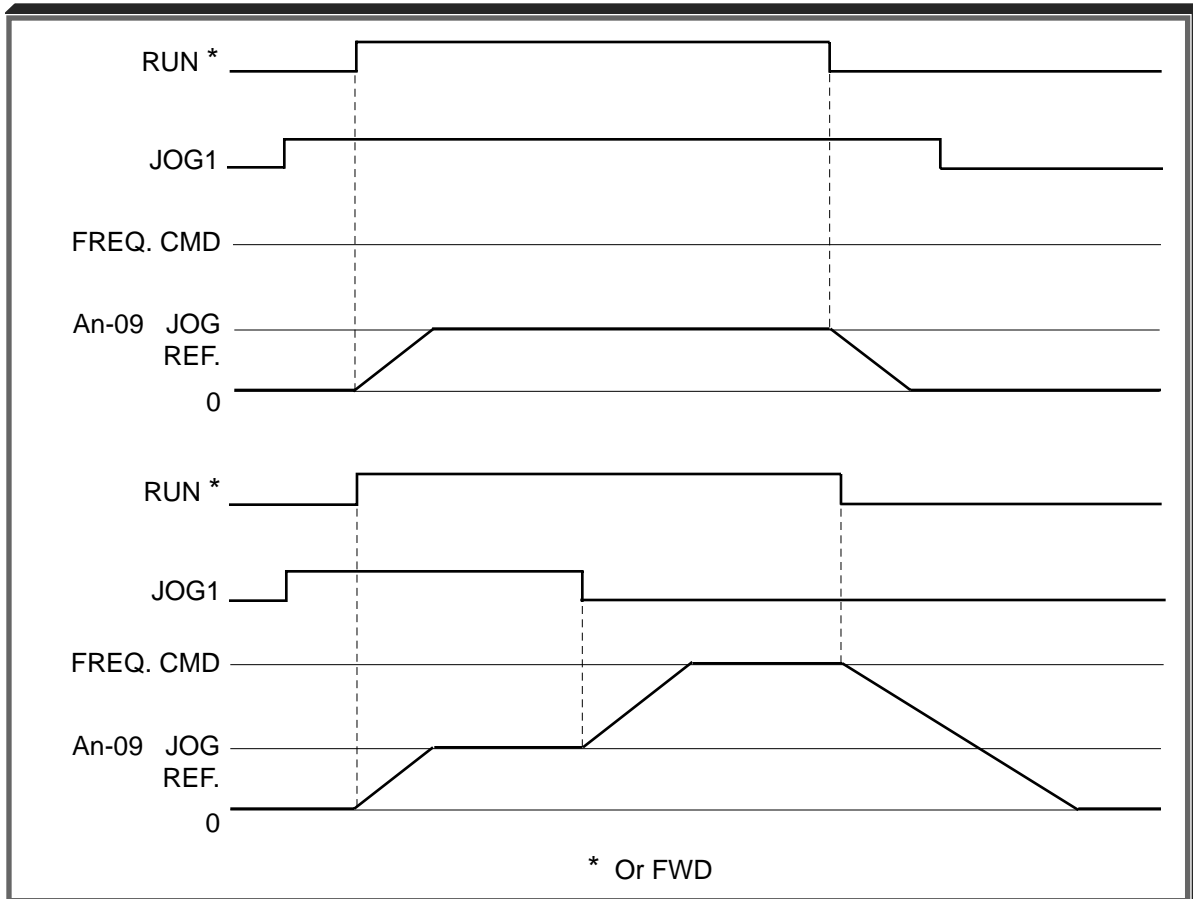

JOG2 - 2-WIRE CONFIGURATION

Sn-04 = **0000** (Remote Control)

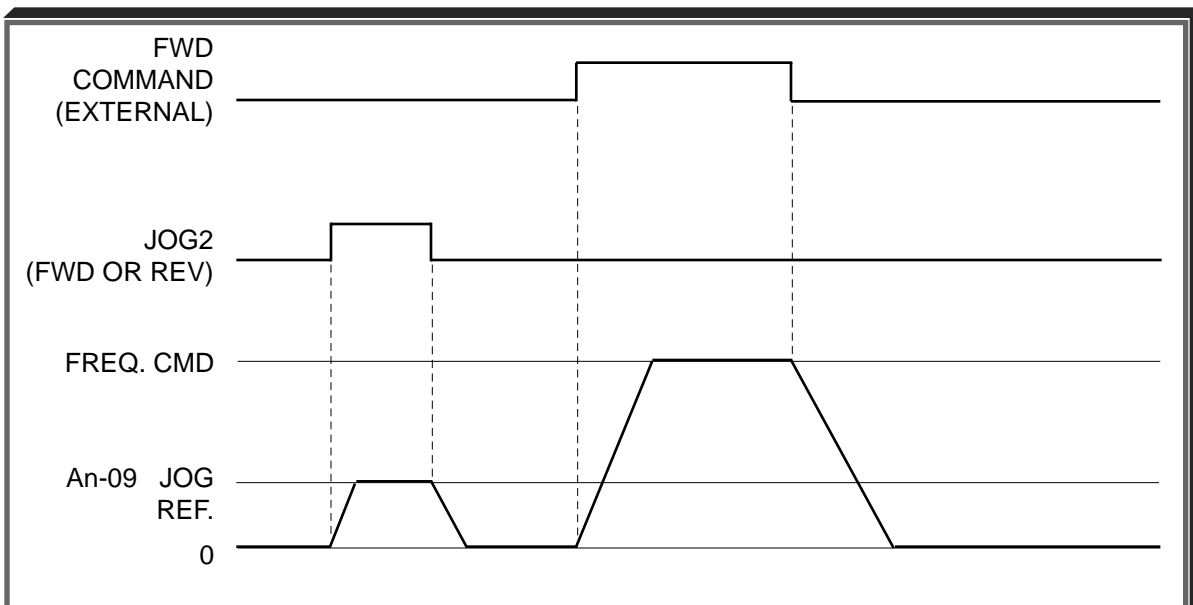

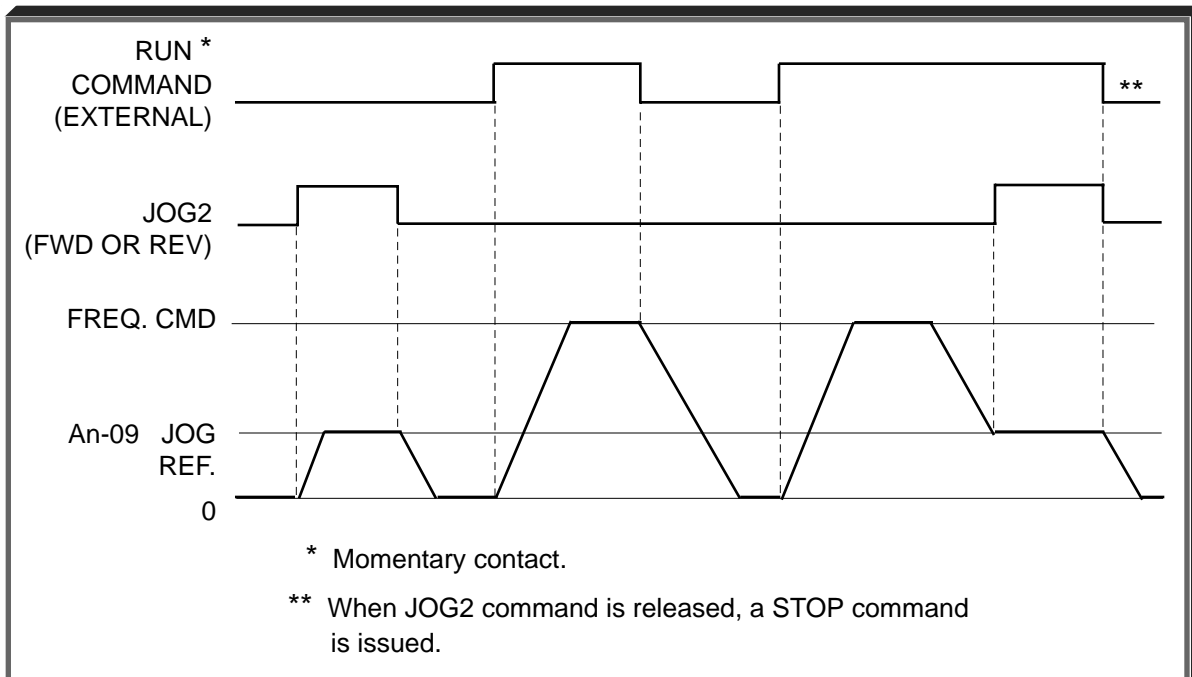
EXAMPLES: (Continued)**JOG2 – 3-WIRE CONFIGURATION**Sn-04 = **0000** (Remote Control)**NOTES:**

- Use of external Jog input is selected by setting data **06**, **12**, or **13** in one of the constants Sn-15 thru Sn-18.
 - The factory configuration for 2-wire control is Sn-17 = **06**, for JOG1 input at terminal 7.
 - The factory configuration for 3-wire control is Sn-18 = **06**, for JOG1 input at terminal 8.
 - To select JOG2 - FWD, set data **12** into one of these constants. To select JOG2 - REV, set data **13** into one of these constants. JOG2 does not require an active RUN command to allow Jog operation.
- JOG2 (FWD or REV) has priority over FWD and REV Run in 2-wire control configuration, and priority over RUN, STOP, and FWD/REV commands in 3-wire control configuration.
- JOG2 - FWD and JOG2 - REV can be selected independently.
- Sn-05 = **XX1X** (Reverse Run disabled) will override JOG2 - REV.

Also see descriptions of **MULTI-FUNCTION INPUT TERMINALS** and **RESET CODES**.

2.16 MOMENTARY POWER LOSS RIDE-THRU

Sn-11: Protective Characteristics
Select 2

Digit 3 [**X X X X**] : Power Loss
Ride-thru Protection

X **0** X X = Disabled (Factory
setting)
X **1** X X = Enabled

The setting of this digit either enables or disables the ride-thru feature of the GPD 503. If disabled, the unit will stop immediately whenever a power loss occurs. If enabled, the GPD 503 will continue to operate during a momentary power loss of up to 80%, under the following conditions:

If the loss exceeds the identified time period, the GPD 503 will stop.

- 230/460V/575V units 5HP and above - max “ride-thru”: 2 seconds
- 230/460V units less than 5HP - “ride-thru”: 1 second (as standard)

The ride-thru capacity of the 230/460V units less than 5HP can be extended to 2 seconds (2000 msec) with the addition of an optional external capacitor unit.

Cn-37: Power Loss Ride-Thru Deactivation Time

Range: 0.0 to 2.0 seconds

If the loss exceeds the length of time identified by Cn-37, the GPD 503 will stop. The factory setting of this constant, in 0.1 second increments, is related to the GPD 503’s HP rating, as set by Sn-01.

2.17 MONITOR DISPLAY (DIGITAL OPERATOR)

While in the Drive mode, different information will appear on the Digital Operator display when each of the Un constants is selected (see page 3-7).

CONSTANT Un-	MONITORED ITEM	DISPLAY EXAMPLE
01	Frequency reference	60.0
02	Output frequency	60.0
03	Output current	12.5A
04	AC voltage reference	230 v
05	DC Bus voltage (VPN)	Pn270
06	Output power (kW)	(±) 12.5
07	Input terminal status	CIIII *
08	Output signals status	o III **
09	LED lamp check	8.8.8.8.8.
10	Control Section PROM (last 5 digits of PROM Part No. : NSG 6XXXXX	16142

* Actual display appearance:

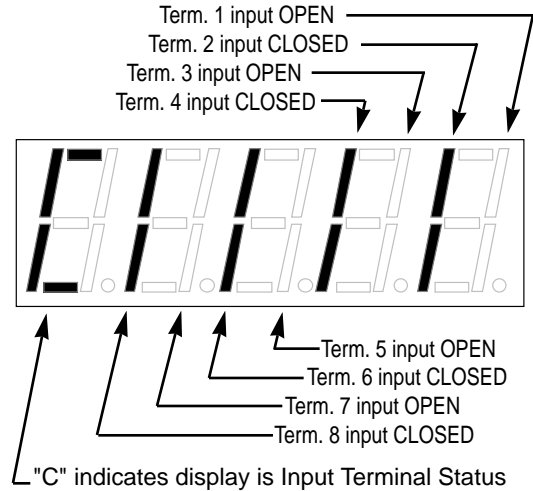

** Actual display appearance:

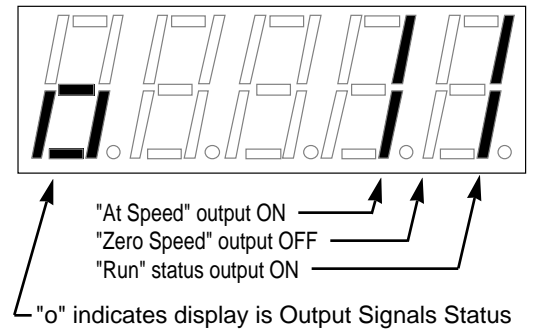

2.18 MULTI-FUNCTION ANALOG INPUT (Term. 16)

Sn-19: Multi-function Analog Input (Term. 16)

Programming Sn-19 per the chart below configures terminal 16 for analog control. The figures on the next page show how each setting configures the analog input.

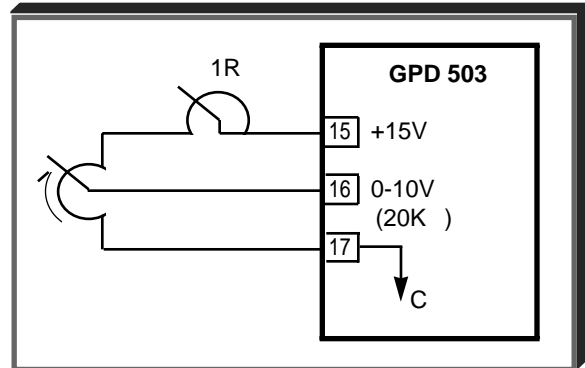

SET VALUE	FUNCTION	REMARKS
00	Manual reference	External reference input
01	Frequency reference gain (FGAINE)	Total gain = Internal gain (bn-05) x FGAINE
02	Frequency reference bias 1 (FBIAS1) *	Total bias = Internal bias (bn-06) + FBIAS1
03	Frequency reference bias 2 (FBIAS2) (+/-) *	Total bias = Internal bias (bn-06) + FBIAS2
04	Overtorque detection level	Internal overtorque detection level (Cn-26) disabled
05	VBIAS **	VBIAS addition after V/f conversion
06	Accel/decel time coefficient	Accel/decel time varied by analog input
07	DC injection braking current adjust	DC injection braking current varied by analog input (10V/drive rated current); internal setting (Cn-11) ineffective
08	Stall prevention level during running	Stall prevention level (Cn-30 = 100% level) varied by analog input
09	Frequency reference lower limit	Frequency reference lower limit is set by analog input. Either Cn-15 setting value or analog input, whichever is greater, becomes effective.
0A	Setting prohibited frequency 4	Analog input sets a fourth prohibited frequency, in addition to those set by Cn-16 thru Cn-18.
0b - FF	Not Used	

* FBIAS1 and FBIAS2 are based on Fmax (Cn-02).

** DC boost adjust on V/Hz curve.

2.18 MULTI-FUNCTION ANALOG INPUT (Term. 16)

Continued

Sn-19 = 00

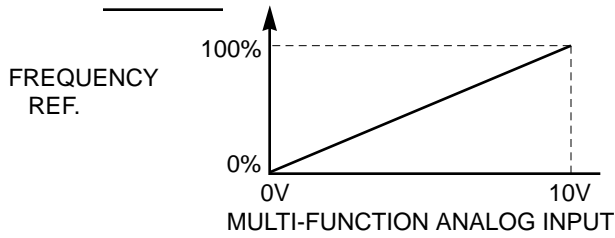

Sn-19 = 01

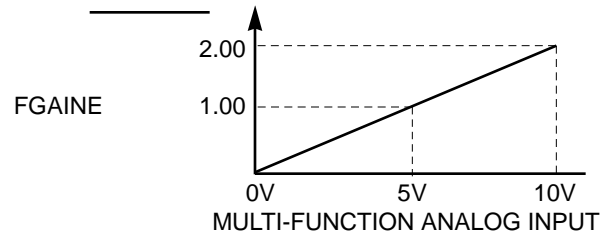

Sn-19 = 02

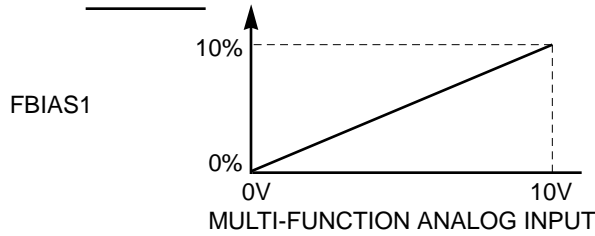

Sn-19 = 03

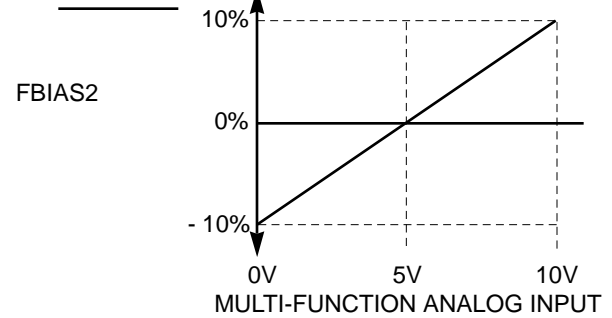

Sn-19 = 04

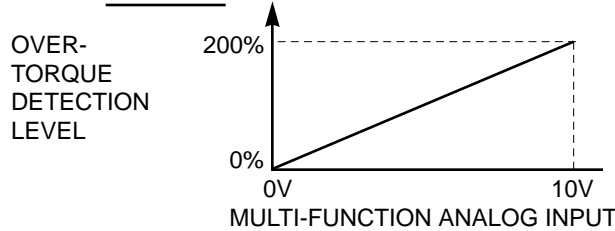

Sn-19 = 05

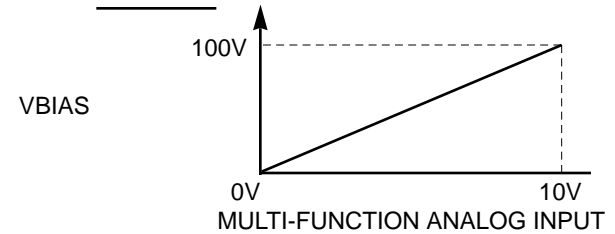

Sn-19 = 06

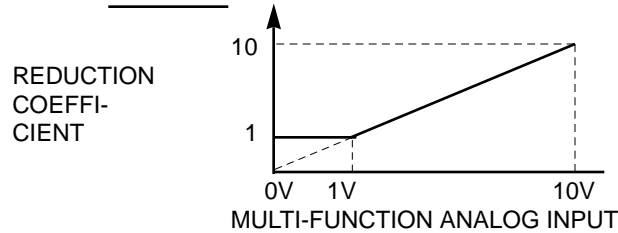

Sn-19 = 07

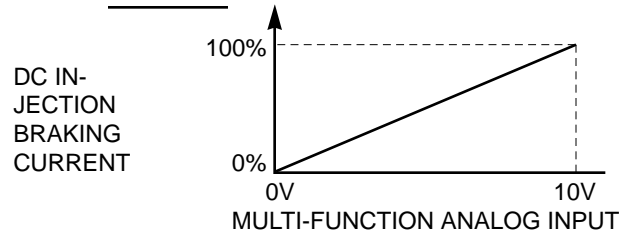

$$\text{Actual Accel or decel time} = \frac{\text{Accel or decel time}}{\text{Coefficient}}$$

Sn-19 = 08

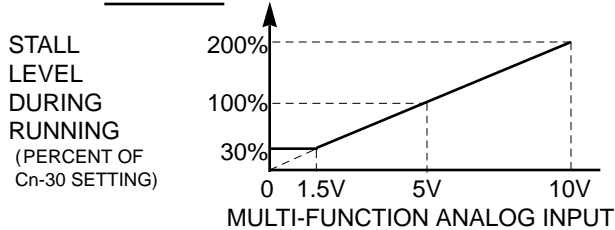

Sn-19 = 09

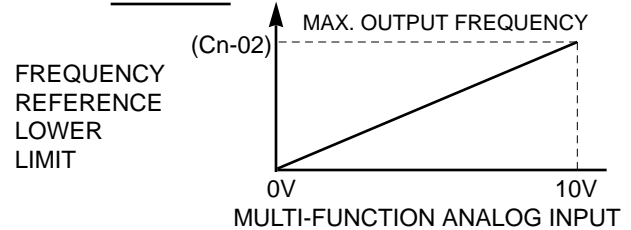

Sn-19 = 0A

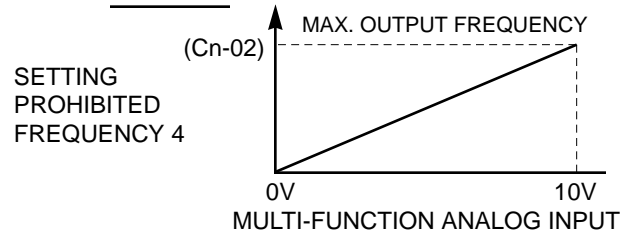

2.19 MULTI-FUNCTION INPUT TERMINALS (Term. 5-8)

Sn-15: Terminal 5 Function
Sn-16: Terminal 6 Function
Sn-17: Terminal 7 Function
Sn-18: Terminal 8 Function

Factory settings (for 2-wire control):

Sn-15 = **03** Sn-17 = **06**
Sn-16 = **04** Sn-18 = **08**

3-wire control defaults:

Sn-15 = **00** Sn-17 = **04**
Sn-16 = **03** Sn-18 = **06**

These four constants select the input signal functions for terminals 5 thru 8. Although these constants can be independently set, NOT selecting values **00** thru **03**, inclusive, establishes that GPD 503 operation will be controlled by the Auto Reference input.

System constant settings are checked whenever power is applied to the GPD 503, or each time GPD 503 operation is switched from Program mode to Drive mode. A constant set value failure (**oPE03**) will occur if any of the following conditions are detected among these four system constants:

- (1) Set values are not arranged in sequence, with the smallest value in Sn-15 and the largest value in Sn-18.
- (2) Both speed search functions (values **61** and **62**) have been selected.
- (3) When the UP and DOWN functions are not selected simultaneously.

Table 2-2 lists the possible data setting values for these constants, with the function and a brief description for each one.

For a few of the data settings, a more detailed description is given on the following pages; for others, the description is given in other PROGRAMMABLE FEATURES paragraphs.

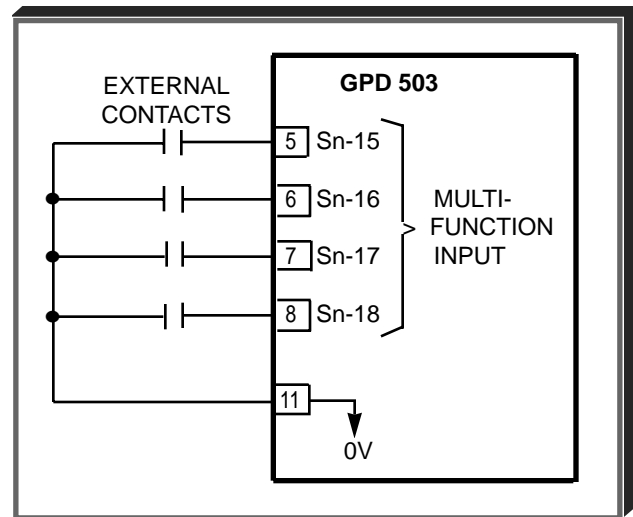

2.19 MULTI-FUNCTION INPUT TERMINALS (Term. 5-8)

Continued

Table 2-2. Sn-15 thru Sn-18 Data Settings

DATA	FUNCTION	DESCRIPTION Signal Levels: 0 = maintained; 1 = momentary
00	FWD/REV selection (for 3-wire control)	MUST BE SET IN Sn-15. Redefines terminals: 1 = Run; 2 = Stop; 5 = FWD/REV select
01	Operation signal selection (Remote/Local)	Open 0 = Operates according to setting of Sn-04, digits 1 & 2 [X X 0 0] Closed 0 = Operates from keys of the Digital Operator See Data description following this table
02	Option/GPD 503 reference selection	Open 0 = Operates from installed option Closed 0 = Operates from Digital Operator and/or external terminals
03	Multi-step speed ref. 1	See paragraph 2.24
04	Multi-step speed ref. 2	
05	Multi-step speed ref. 3	
06	JOG1 selection	Closed 0 = Jog selected See paragraph 2.15
07	Accel/decel time	Open 0 = Accel/decel by bn-01/bn-02 Closed 0 = Accel/decel by bn-03/bn-04 See paragraph 2.2
08	External base block (N.O. contact input)	Closed 0 = Shuts off GPD 503 output (frequency command is held) See Data description following this table
09	External base block (N.C. contact input)	Open 0 = Shuts off GPD 503 output (frequency reference is held) See Data description following this table
0A	Accel/decel speed prohibit (HOLD command)	See Data description following this table
0b	External overheat	Closed 0 = oH2 blinks on the Digital Operator, and operation continues (minor fault)
0C	Multi-function analog input selection	Closed 0 = Analog input (term. 16) is enabled Open 0 = Analog input (term. 16) is disabled
0D to 0F	Not Used	
10	UP function	See paragraph 2.34
11	DOWN function	
12	JOG2 - FWD	See paragraph 2.15
13	JOG2 - REV	

2.19 MULTI-FUNCTION INPUT TERMINALS (Term. 5-8) Continued

Table 2-2. Sn-15 thru Sn-18 Data Settings - Continued

DATA	FUNCTION	DESCRIPTION Signal Levels: 0 = maintained; 1 = momentary
14 to 1F	Not Used	
20 to 2F	External fault 1	Second digit of setting is a hexadecimal value; its four-place binary equivalent defines what type of external contact is used and how the GPD 503 will react when the signal input is active See paragraph 2.12
30 to 3F	External fault 2	
40 to 4F	External fault 3	
50 to 5F	External fault 4	
60	DC injection braking command (RUN and JOG have priority)	Closed 0 = DC injection braking active See paragraph 2.8
61	Speed Search 1	Closed 1 = Speed Search operation from maximum frequency See paragraph 2.28
62	Speed Search 2	Closed 1 = Speed Search operation from set frequency See paragraph 2.28
63	Energy-saving operation	Closed 0 = Energy saving See paragraph 2.11
64 to FF	Not Used	

Data 01: Remote/Local

Set digits of Sn-04 to X X 0 0 to select external inputs as the source for frequency reference and operation commands. The use of a Remote/Local command input allows switching between the Digital Operator control and the external terminal input signals, without the need of re-programming Sn-04. If the status of the Remote/Local command input is changed while the drive is running, the Remote/Local operation selection is not completed until the next time the GPD 503 is stopped.

Closed = Controlled locally (Digital Operator)

Open = Controlled remotely (external terminal inputs, and Auto reference)

NOTE: If manual speed is selected

- by the external Auto/Manual switch (3SS [2-wire] or 2SS [3-wire]),
 - by jumper from term. 5 to 11 (2-wire control),
- or

- by jumper from term. 6 to 11 (3-wire control),

the GPD 503 speed reference will be controlled by manual speed reference regardless of the state of the Remote/Local input.

2.19 MULTI-FUNCTION INPUT TERMINALS (Term. 5-8)

Continued

Data 08: External Base Block by N.O. Contact

- When either the Forward Run command or Reverse Run command is closed, and the external Base Block command is also active (i.e. contact closed), coast stop is accomplished (after a 20 msec delay), while the frequency command is maintained. When the Base Block command is removed, the drive will recover in a manner similar to that of Speed Search operation.

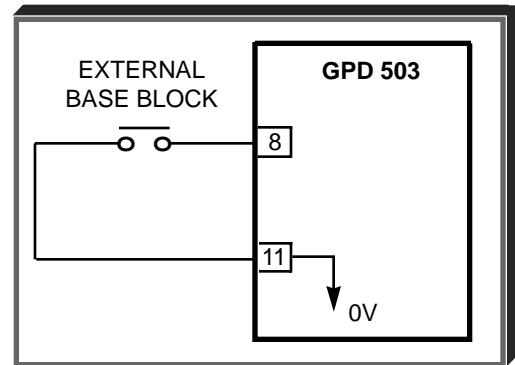

- When both the Forward Run command and Reverse Run command are open, and the external Base Block command is active (i.e. contact closed), coast stop is accomplished and after a 20 msec delay the frequency command is changed to 0Hz. When the Base Block command is removed, the drive will remain in stopped condition until Forward Run command or Reverse Run command is again closed.
- When external Base Block command is active, a blinking " *b b* " will be displayed on the Digital Operator.

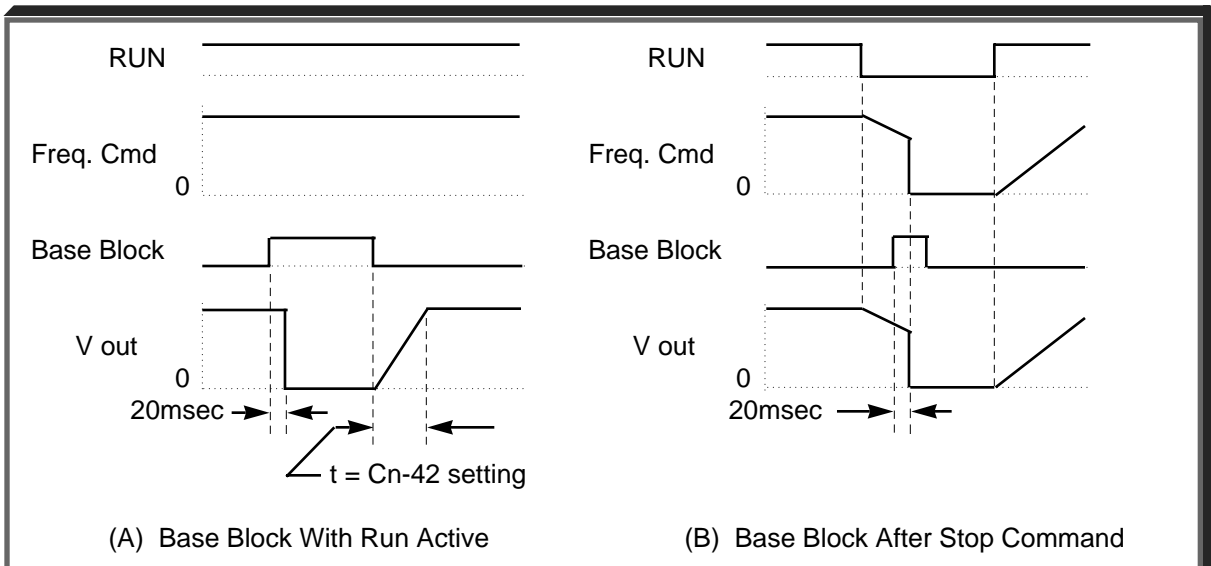

Data 09: External Base Block by N.C. Contact

Base block operation is the same as described above, except that the Base Block contact must be *open* to be recognized as active.

2.19 MULTI-FUNCTION INPUT TERMINALS (Term. 5-8) Continued

Data 0A: Accel/Decel Speed Prohibit (HOLD Command)

As long as the HOLD command is present, accel and decel are in a prohibit state, and the output frequency is held at the level it was at the time the HOLD command was input. When the HOLD command is removed while the system is still in Run condition, accel and decel will again become active to allow output to reach set frequency. If Stop is initiated while the HOLD command is present, the prohibit state is cancelled and the system enters stop operation.

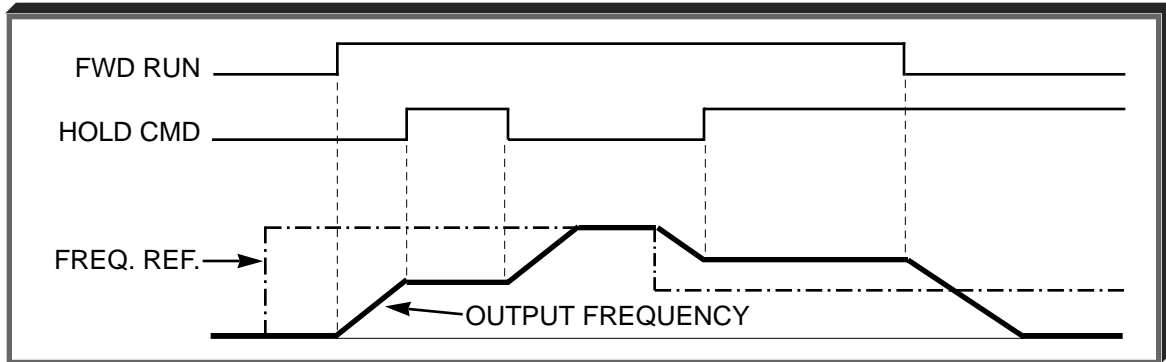

HOLD Function Timing

2.20 MULTI-FUNCTION ANALOG MONITOR OUTPUT (Term. 21 & 22)

Sn-05: Operation Mode Select 2

Digit 4 [X X X X] : Multi-function Analog Output

Factory setting: 0 X X X

Sn-09: Analog Monitor Selection

Digit 2 [X X X X] : Multi-function Analog Output

Factory setting: X X 0 X

The monitor output provides a 0-10 Vdc signal proportional to either output frequency, output current, output voltage reference, or output power between terminals 21 & 22:

<u>Sn-05</u>	<u>Sn-09</u>	
0 X X X	X X 0 X	= 0-10 Vdc proportional to output frequency
1 X X X	X X 0 X	= 0-10 Vdc proportional to output current
0 X X X	X X 1 X	= 0-10 Vdc proportional to output voltage reference
1 X X X	X X 1 X	= 0-10 Vdc proportional to output power.

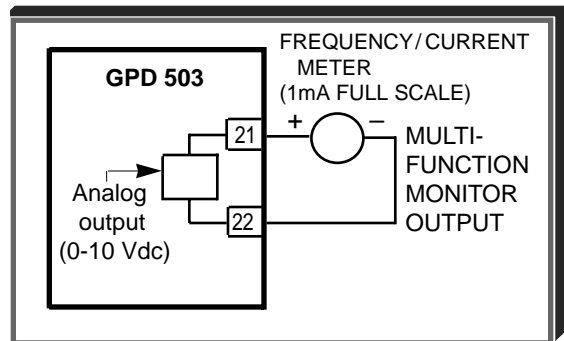

bn-11: Analog Monitor Channel 1 Gain

Factory Setting: 1.00

Range: 0.01 to 2.55

This constant is used to calibrate, in increments of 0.01, either the frequency or current meter connected to terminals 21 & 22. This function is also used to calibrate Channel 1 of one of the analog output options.

NOTE: When an analog output option is connected, bn-11 setting affects both terminals 21 & 22 and the option terminals for Channel 1.

2.21 MULTI-FUNCTION OUTPUT TERMINALS (Term. 9 & 10; 25-27)

Sn-20: Contact Output (external terminals 9 & 10)

Sn-21: Open Collector Output (external terminals 25 & 27)

Sn-22: Open Collector Output (external terminals 26 & 27)

A contact, or two different open collector outputs, can be programmed to change states during any of the conditions indicated in Table 2-3.

If an open collector output is applied to a DC relay, the relay **MUST** be diode protected, as shown in the recommended configuration.

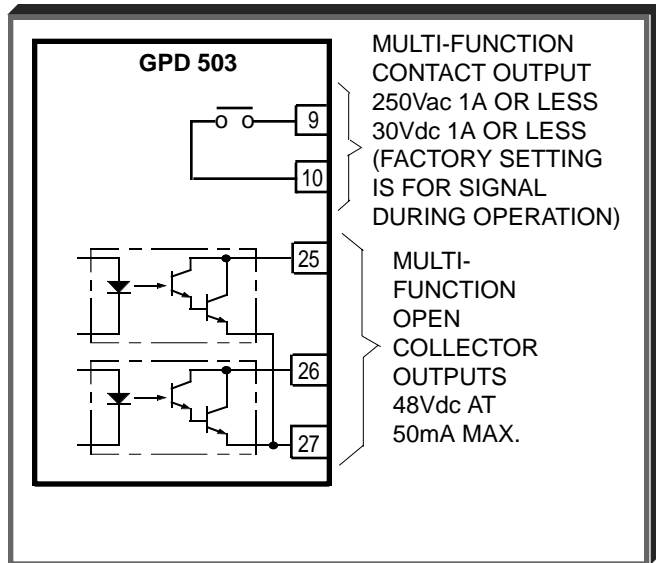

Table 2-3. Multi-function Output Terminals

Set Value	Description	
	Condition	Signal Level
00	During operation	Closed = GPD 503 is operating
01	Zero speed	Closed = GPD 503 output is at 0Hz
02	Speed at set frequency	Closed = Freq. Ref. - Cn-22 ≤ output freq ≤ Freq.Ref + Cn-22
03	Speed coincidence	Closed = Speed at set frequency and Cn-21 - Cn-22 ≤ output freq. ≤ Cn-21 + Cn-22
04	Frequency detection - low	Closed = Output frequency ≤ Cn-21
05	Frequency detection - high	Closed = Output frequency ≥ Cn-21
06	Operation ready	Closed = GPD 503 is ready for operation
07	During undervoltage detection	Closed = Undervoltage detected
08	During coast to stop	Closed = GPD 503 output base block is active; motor is coasting
09	Frequency reference mode	Open = Cmd by ext. input; Closed = Cmd by Digital Operator
0A	Run reference mode	Open = Run by ext. input; Closed = Run by Digital Operator
0b	Overtorque detection	Closed = Overtorque detected
0C	Frequency reference missing	Closed = Frequency reference is missing
0d	Braking resistor fault	Closed = Braking resistor is overheating or has faulted
0E	Fault	Closed = GPD 503 fault has occurred (except CPF00, CPF01)
0F	Not Used	

2.21 MULTI-FUNCTION OUTPUT TERMINALS (Term. 9 & 10; 25-27)

Continued

Recommended
Configuration for
DC Relays

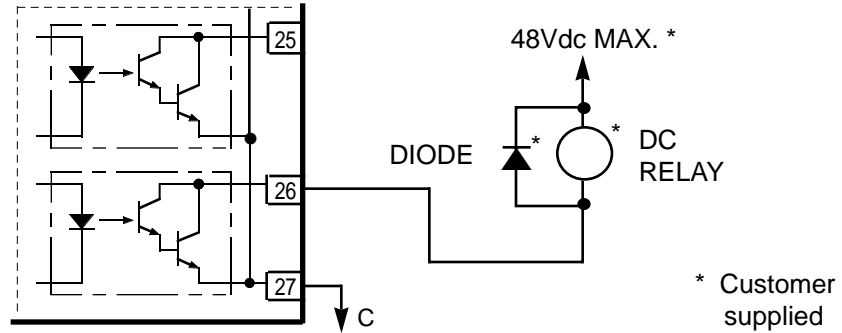

2.22 OVERTORQUE DETECTION

Overtorque detection is used to compare GPD 503 rated output current with the overtorque detection level. When the output current is equal to or greater than the defined level, an overtorque condition exists. This will be indicated as an **oL3** fault on the Digital Operator. This feature can be selected to operate over a wide range of conditions. (Refer to Appendix 3, Table A3-1.)

Cn-26: Overtorque Detection Level

Factory setting: **160 %**

Range: 30 to 200 %

Overtorque detection level determines the point at which the GPD 503 determines that an overtorque condition exists.

Cn-27: Overtorque Detection Time

Factory setting: **0.1 sec.**

Range: 0.0 to 25.5 seconds

Overtorque detection time determines how long an overtorque condition must exist before another event will occur, e.g. coast to stop, or continue operation when overtorque is detected.

Sn-07: Overtorque Detection
Mode Select

X X X **0** = Overtorque detection disabled

X X X **1** = Overtorque detection is enabled

The setting of this digit either enables or disables overtorque detection.

X **0** X 1 = Operation continues

X **1** X 1 = Coast stop

Once overtorque detection is selected, the setting of this digit determines GPD 503 operation after the overtorque condition is recognized. The GPD 503 either continues to operate, or coasts to stop when overtorque is detected.

X X **0** 1 = Overtorque detection at set frequency

X X **1** 1 = Overtorque detection always detected

The setting of this digit selects when overtorque condition is considered, either only at set frequency, or always detected (except during stopping and Dynamic Braking).

2.22 OVERTORQUE DETECTION

Continued

Sn-19: Multi-function Analog Input (Term. 16)

Data 04: External Overtorque Detection Level Adjustment

The multi-function analog input at terminal 16 may be configured to allow analog control of the overtorque detection level. When this function is programmed into Sn-19, the internal overtorque detection level (Cn-26) is disabled.

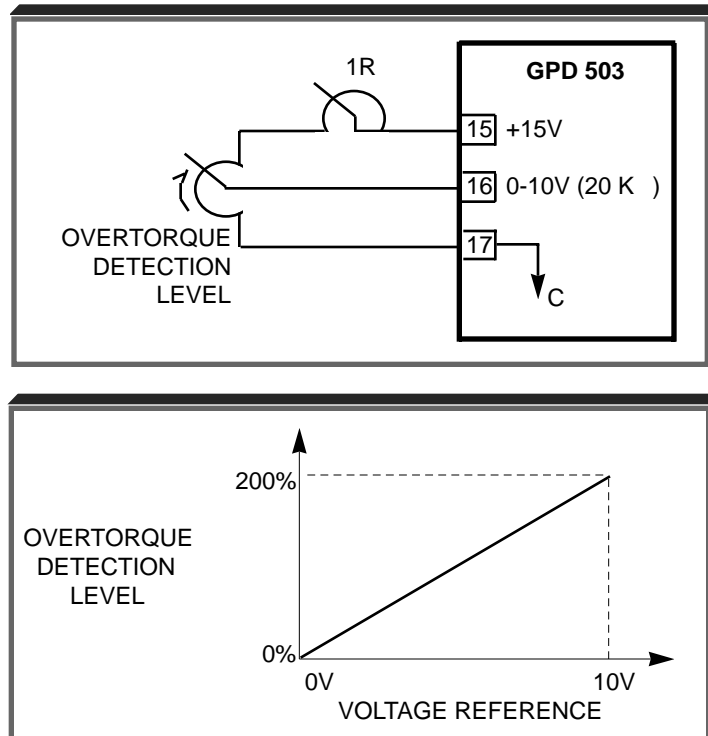

Sn-20: Multi-function Output 1 – Contact (terminals 9 & 10)

Sn-21: Multi-function Output 2 – Open Collector (terminals 25 & 27)

Sn-22: Multi-function Output 3 – Open Collector (terminals 26 & 27)

Data 0b: Overtorque Detection

A contact, or two open collector outputs, can be programmed to change states during an overtorque detection condition.

2.22 OVERTORQUE DETECTION Continued

EXAMPLE OF OVERTORQUE DETECTION

- Sn-07 setting: **0101** — Overtorque enabled, and only at set frequency
- Sn-19 setting: **00** — Cn-26 value is overtorque detection level
- Sn-20 setting: **0b** — Output contact programmed for overtorque detection
- Cn-26 setting: **110** % — Level at which overtorque is sensed
- Cn-27 setting: **1.0** s — Time delay before overtorque event occurs

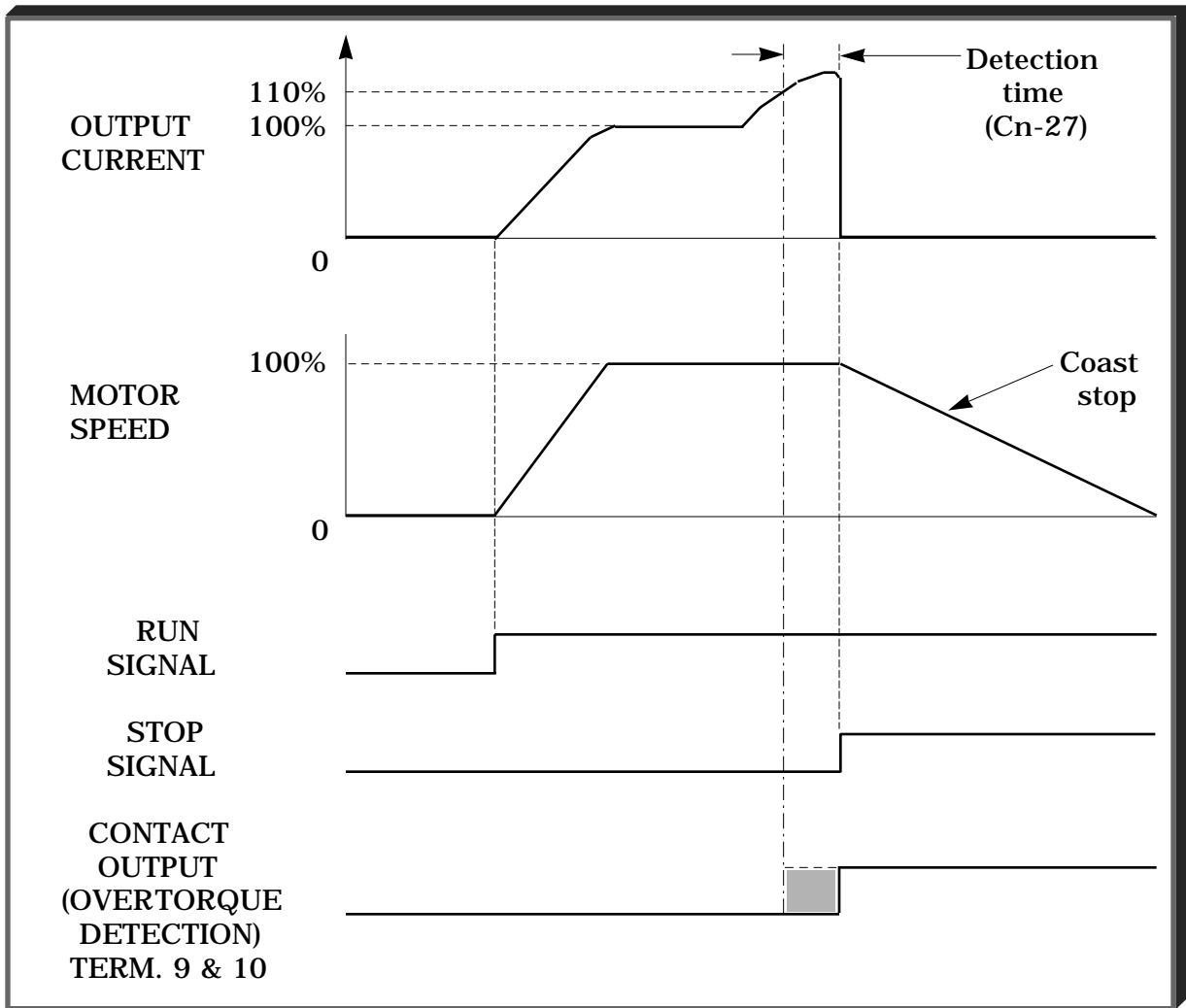

Overtorque Detection Timing Diagram

2.23 SPEED COINCIDENCE

Cn-21: Speed Coincidence Frequency

Factory setting: **0.0** Hz

Range: 0.0 to 400.0 Hz

Cn-22: Speed Coincidence Bandwidth

Factory setting: **2.0** Hz

Range: 0.0 to 25.5 Hz

Speed coincidence is used to control an output contact at terminals 9 & 10, or one of the open collector outputs at terminals 25 & 26 (with respect to terminal 27), when selected by Sn-20 thru Sn-24.

Sn-20: Multi-function Output 1 – Contact
(terminals 9 & 10)

Sn-21: Multi-function Output 2 – Open Collector
(terminals 25 & 27)

Sn-22: Multi-function Output 3 – Open Collector
(terminals 26 & 27)

Data **02, 03, 04** or **05**
(See paragraph 2.21,
MULTI-FUNCTION
OUTPUT TERMINALS
(Term. 9 & 10; 25-27))

The output contact will close, or the open collector output will go low, when acceleration or deceleration is completed, and output frequency is within the detection width shown in the figure below.

EXAMPLE:

If Cn-21 = **20** Hz, Cn-22 = **15.0** Hz and Sn-20 = **03**, then the contact at terminals 9 & 10 will be closed from 25 Hz to 35 Hz.

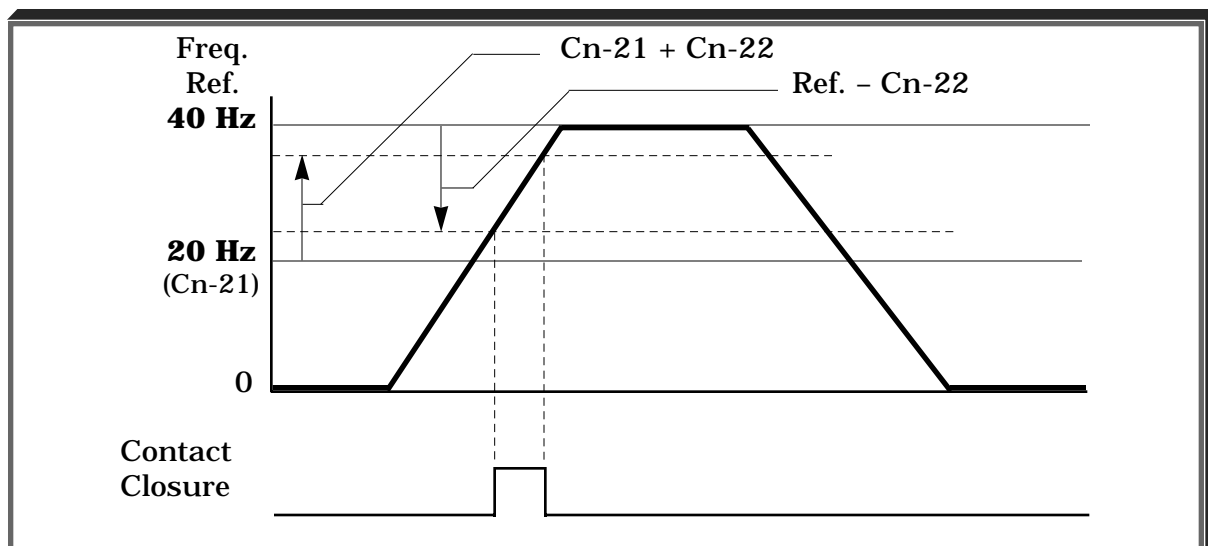

2.24 REMOTE/LOCAL AND REFERENCE SELECTION

An-01: Memory 1

An-02: Memory 2

An-03: Memory 3

An-04: Memory 4

An-05: Memory 5

An-06: Memory 6

An-07: Memory 7

An-08: Memory 8

An-09: Jog Reference
(See paragraph 2.15)

Sn-19: Multi-function Analog Input (Term. 16) (see paragraph 2.18)

Sn-04: Operation Mode Select 1

Sn-15 thru Sn-18: Multi-function Input Terminals; data **03**, **04**, **05** and **06** [or **0C**], respectively, for Reference Select 1, 2, 3 and Jog [or Multi-function Analog Input at Term. 16] (see paragraph 2.19).

For Remote/Local select, see paragraph 2.19, **Data 01** description.

Sn-08: Option Reference Select (See separate Option Instruction Sheet)

The GPD 503 allows selection of one of twelve references. Two are analog inputs, nine are stored in memory, and one can be from an option card, either analog or digital. In most configurations either the local reference (An-01) or the remote AUTO reference will be utilized.

2.24.1 Local Reference Selection

Sn-04: Operation Mode Select 1

Data: X X X 0 = Remote (Auto) speed reference X X X 1 = Local (manual) frequency ref.
--

By programming Sn-04 to X X X **0** , the external Auto reference input will be used. If Sn-04 is programmed to X X X **1** , the value in An-01 will be used as a frequency command.

IMPORTANT

An-01 will change each time the operator enters a new frequency command from the Digital Operator's " **F X X X. X** " prompt. Another way to think about this is that when the GPD 503 is first powered up, the Digital Operator displays frequency reference: " **F X X X. X** ". The value displayed is the current setting of An-01. If the operator changes the display, then An-01 will also be changed.

2.24.2 Multiple Speed Reference Configuration [Multi-step Speed Operation]

In a multiple reference configuration, five modes may be selected.

NOTE

In the descriptions of Mode 1 thru Mode 4, the external terminal listings differ depending on whether the drive is set for 2-wire or 3-wire control. For 3-wire control, terminal 5 is dedicated to the FWD/REV selection; therefore, multiple reference operation will use fewer of the memory settings and is a more limited function.

Depending on the control wiring configuration and the multi-step mode chosen, the motor can be operated at up to nine different speeds.

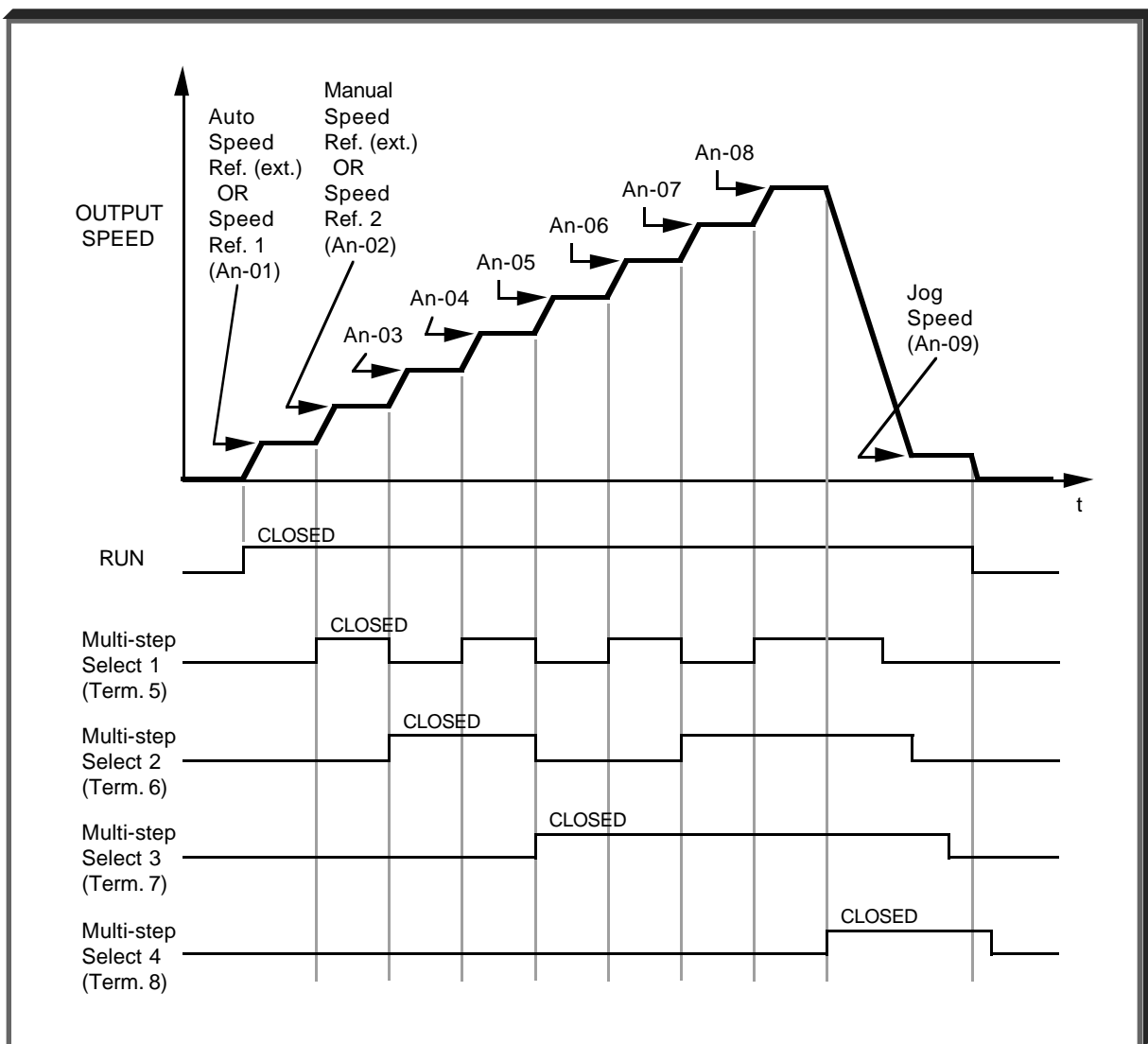

Typical Multi-step Speed Operation

2.24 REMOTE/LOCAL AND REFERENCE SELECTION

Continued

Mode 1 (Memory Data Only) uses only memory locations An-01 thru An-09.

The input commands at terminals 5 thru 8 are binary coded to select the appropriate reference command, where An-01 is selected by binary zero and An-09 (Jog) is selected by binary 8. For example, if the value in An-04 is the desired frequency reference, enter 0011 at terminals 5 thru 8. As a standard, the right-most bit and terminal 5 are the least significant bit (LSB).

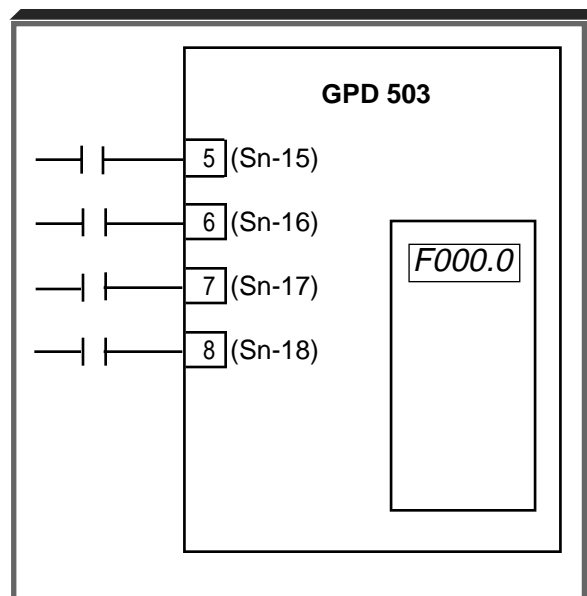

Sn-04 = local operation.

Sn-15 = frequency reference select 1 at terminal 5.

Sn-16 = frequency reference select 2 at terminal 6.

Sn-17 = frequency reference select 3 at terminal 7.

Sn-18 = JOG reference select at terminal 8.

Sn-19 = manual reference at terminal 16.

2-WIRE CONTROL

Sn-04 = X X X 1

Sn-15 = **03**

Sn-16 = **04**

Sn-17 = **05**

Sn-18 = **06**

Sn-19 = **00** *

3-WIRE CONTROL

Sn-04 = X X X 1

Sn-15 = **00**

Sn-16 = **03**

Sn-17 = **04**

Sn-18 = **06**

Sn-19 = **00** *

Freq. Ref.	External Terminal			
	8	7	6	5
An-01	0	0	0	0
An-02 *	0	0	0	1
An-03	0	0	1	0
An-04	0	0	1	1
An-05	0	1	0	0
An-06	0	1	0	1
An-07	0	1	1	0
An-08	0	1	1	1
An-09	1	X	X	X

Freq. Ref.	External Terminal			
	8	7	6	5
An-01	0	0	0	■
An-02 *	0	0	1	■
An-03	0	1	0	■
An-04	0	1	1	■
An-09	1	X	X	■

1 = Closed; 0 = Open;
X = No effect; ■ = FWD/REV

* Sn-19 selects the function of the multi-function analog input. If data value **00** is entered, the analog input represents manual reference. If An-02 is to be utilized, then Sn-19 MUST NOT be set to **00**.

2.24 REMOTE/LOCAL AND REFERENCE SELECTION

Continued

Mode 2 (Memory, Auto, Manual) uses Auto, Manual and An-03 thru An-09.

The input commands at terminals 5 thru 8 are binary coded to select the appropriate reference command, where Auto is selected by binary zero and An-09 (Jog) is selected by binary 8. For example, if the value in An-04 is the desired frequency reference, enter 0011 at terminals 5 thru 8. As a standard, the right-most bit and terminal 5 are the LSB.

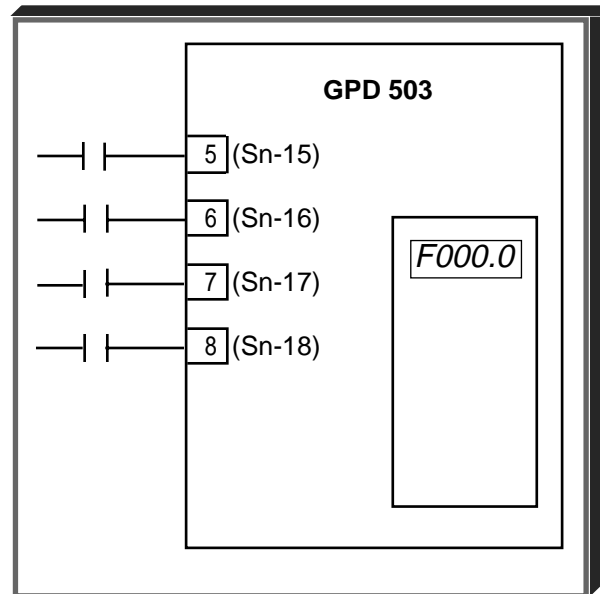

- Sn-04 = remote operation.
- Sn-15 = frequency reference select 1 at terminal 5 (Auto/Manual).
- Sn-16 = frequency reference select 2 at terminal 6.
- Sn-17 = frequency reference select 3 at terminal 7.
- Sn-18 = JOG reference select at terminal 8.
- Sn-19 = manual reference at terminal 16.

2-WIRE CONTROL

- Sn-04 = X X X 0
- Sn-15 = 03
- Sn-16 = 04
- Sn-17 = 05
- Sn-18 = 06
- Sn-19 = 00

3-WIRE CONTROL

- Sn-04 = X X X 0
- Sn-15 = 00
- Sn-16 = 03
- Sn-17 = 04
- Sn-18 = 06
- Sn-19 = 00

Freq. Ref.	External Terminal			
	8	7	6	5
Auto	0	0	0	0
Manual (Multi-func.)	0	0	0	1
An-03	0	0	1	0
An-04	0	0	1	1
An-05	0	1	0	0
An-06	0	1	0	1
An-07	0	1	1	0
An-08	0	1	1	1
An-09	1	X	X	X

Freq. Ref.	External Terminal			
	8	7	6	5
Auto	0	0	0	■
Manual (Multi-func.)	0	0	1	■
An-03	0	1	0	■
An-04	0	1	1	■
An-09	1	X	X	■

1 = Closed; 0 = Open;
X = No effect; ■ = FWD/REV

2.24 REMOTE/LOCAL AND REFERENCE SELECTION

Continued

Mode 3 (An-01, Manual, An-03 thru An-09) uses An-01, Manual and An-03 thru An-09.

The input commands at terminals 5 thru 8 are binary coded to select the appropriate reference command, where An-01 is selected by binary zero and An-09 (Jog) is selected by binary 8. For example, if the value in An-04 is the desired frequency reference, enter 0011 at terminals 5 thru 8. As a standard, the right-most bit and terminal 5 are the LSB.

- Sn-04 = local operation.
- Sn-15 = frequency reference select 1 at terminal 5 (Auto/Manual).
- Sn-16 = frequency reference select 2 at terminal 6.
- Sn-17 = frequency reference select 3 at terminal 7.
- Sn-18 = JOG reference select at terminal 8.
- Sn-19 = manual reference at terminal 16.

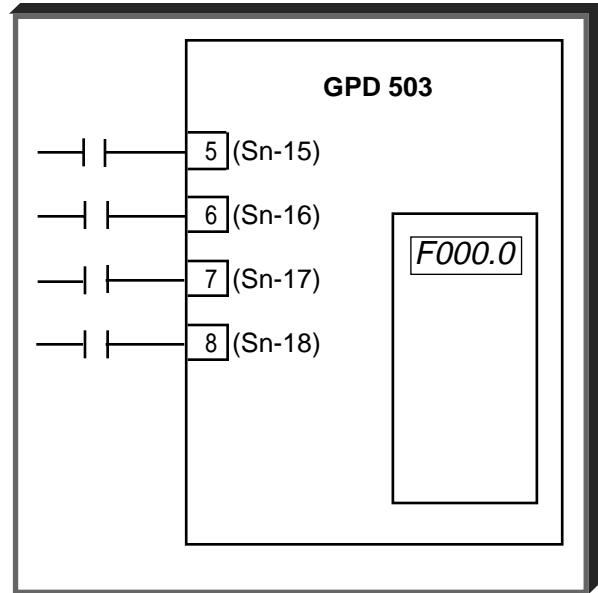

2-WIRE CONTROL

- Sn-04 = X X X 1
- Sn-15 = **03**
- Sn-16 = **04**
- Sn-17 = **05**
- Sn-18 = **06**
- Sn-19 = **00**

3-WIRE CONTROL

- Sn-04 = X X X 1
- Sn-15 = **00**
- Sn-16 = **03**
- Sn-17 = **04**
- Sn-18 = **06**
- Sn-19 = **00**

Freq. Ref.	External Terminal			
	8	7	6	5
An-01	0	0	0	0
Manual (Multi-func.)	0	0	0	1
An-03	0	0	1	0
An-04	0	0	1	1
An-05	0	1	0	0
An-06	0	1	0	1
An-07	0	1	1	0
An-08	0	1	1	1
An-09	1	X	X	X

Freq. Ref.	External Terminal			
	8	7	6	5
An-01	0	0	0	■
Manual (Multi-func.)	0	0	1	■
An-03	0	1	0	■
An-04	0	1	1	■
An-09	1	X	X	■

1 = Closed; 0 = Open;
X = No effect; ■ = FWD/REV

2.24 REMOTE/LOCAL AND REFERENCE SELECTION

Continued

Mode 4 uses An-01 thru An-08 and Analog Manual.

The input commands at terminals 5 thru 8 are binary coded to select the appropriate reference command, where An-01 is selected by binary zero and Analog Manual is selected by binary 8. For example, if the value in An-04 is the desired frequency reference, enter 0011 at terminals 5 thru 8. As a standard, the right-most bit and terminal 5 are the LSB.

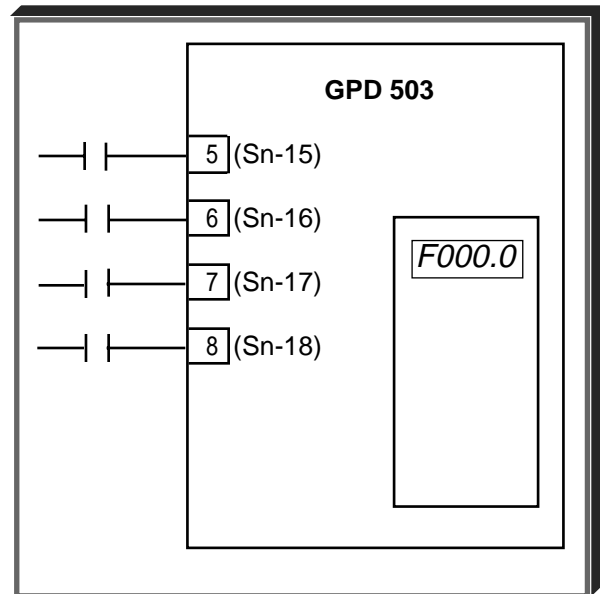

- Sn-04 = remote operation.
- Sn-15 = frequency reference select 1 at terminal 5 (Auto/Manual).
- Sn-16 = frequency reference select 2 at terminal 6.
- Sn-17 = frequency reference select 3 at terminal 7.
- Sn-18 = the multi-function analog input reference select at terminal 8.
- Sn-19 = manual reference at terminal 16.

2-WIRE CONTROL

- Sn-04 = X X X 0
- Sn-15 = 03
- Sn-16 = 04
- Sn-17 = 05
- Sn-18 = 0C
- Sn-19 = 00 *

3-WIRE CONTROL

- Sn-04 = X X X 0
- Sn-15 = 00
- Sn-16 = 03
- Sn-17 = 04
- Sn-18 = 0C
- Sn-19 = 00 *

Freq. Ref.	External Terminal			
	8	7	6	5
An-01	0	0	0	0
An-02 *	0	0	0	1
An-03	0	0	1	0
An-04	0	0	1	1
An-05	0	1	0	0
An-06	0	1	0	1
An-07	0	1	1	0
An-08	0	1	1	1
Analog - Manual	1	X	X	X

Freq. Ref.	External Terminal			
	8	7	6	5
An-01	0	0	0	■
An-02 *	0	0	1	■
An-03	0	1	0	■
An-04	0	1	1	■
Analog - Manual	1	X	X	■

1 = Closed; 0 = Open;
X = No effect; ■ = FWD/REV

* Sn-19 selects the function of the multi-function analog input. If data value 00 is entered, the analog input represents manual reference. If An-02 is to be utilized, then Sn-19 MUST NOT be set to 00.

2.24 REMOTE/LOCAL AND REFERENCE SELECTION

Continued

Mode 5

The final consideration for multiple frequency command configuration modes is that any combination of binary weighted values may be configured for operation. As an example, if only three speed references are required, then the following example will work.

Sn-04 = local operation.

Sn-15 = frequency reference select 1 at terminal 5.

Sn-16 = frequency reference select 2 at terminal 6.

Sn-19 = manual reference at terminal 16.

2-WIRE CONTROL

Sn-04 = X X X **1**

Sn-15 = **03**

Sn-16 = **04**

Sn-19 = **00**

Freq. Ref.	External Terminal			
	8	7	6	5
An-01	0	0	0	0
Manual (Multi-func.)	0	0	0	1
An-03	0	0	1	0

2.25 RESET CODES: 2-WIRE, 3-WIRE INITIALIZATION

Sn-03: Operator Status

Data: **1110** = Factory 2-Wire Control Initialization
1111 = Factory 3-Wire Control Initialization

By entering either code into this constant, a reset to factory configuration (constant initialization) is accomplished. The constants which are **NOT** affected are:

Sn-01: GPD 503 Capacity
Sn-02: V/f

Factory configuration for 2-wire control:

Sn-15 = **03** — Reference Select 1
Sn-16 = **04** — Reference Select 2
Sn-17 = **06** — JOG
Sn-18 = **08** — Coast to Stop/Base Block

Factory configuration for 3-wire control:

Sn-15 = **00** — FWD/REV Select
Sn-16 = **03** — Reference Select 1
Sn-17 = **04** — Reference Select 2
Sn-18 = **06** — JOG

CAUTION

Know your application before using either Initialization function of Sn-03. This constant must be set to 0000 for Drive mode operation.

1110 = Factory 2-Wire Control Initialization (Maintained RUN Contact)

1111 = Factory 3-Wire Control Initialization (Momentary START/STOP Contact)

Entering either Initialization code resets all constants EXCEPT Sn-01 AND Sn-02 to factory settings, and automatically returns Sn-03 setting to 0000. If the GPD 503 is connected for 3-Wire control and this constant is set to 1110 (2-Wire Control Initialization), the motor may run in reverse direction WITHOUT A RUN COMMAND APPLIED. Equipment damage or personal injury may result.

2.26 SLIP COMPENSATION

bn-08: Slip Compensation Gain

Factory setting: **0.0** %

Range: 0.0 to 9.9 %

This constant sets the slip compensation gain, in increments of 0.1%. When the gain is 1.0, the output frequency is increased by 1% of the Cn-04 setting at rated current. A setting of 0.0 results in no slip compensation.

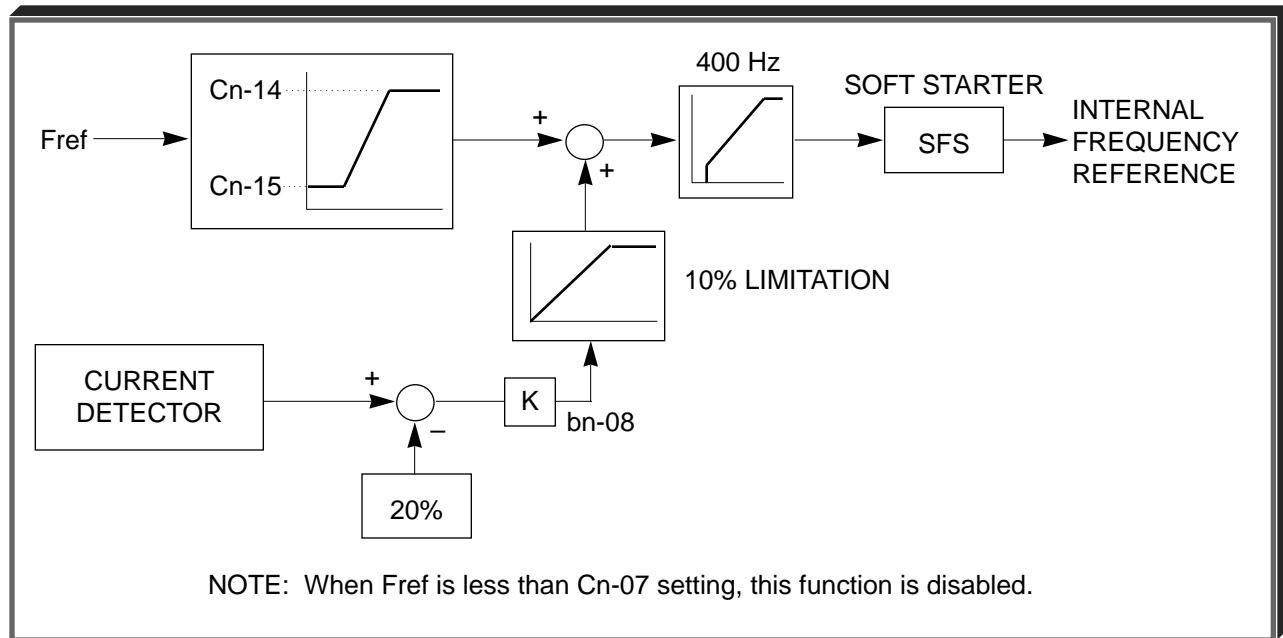

Slip Compensation Block Diagram

EXAMPLE:

Desired frequency is 45 Hz
 Motor slip = 3% at full load
 (bn-08 = 3.0)
 Actual output frequency at
 full load = 46.35 Hz

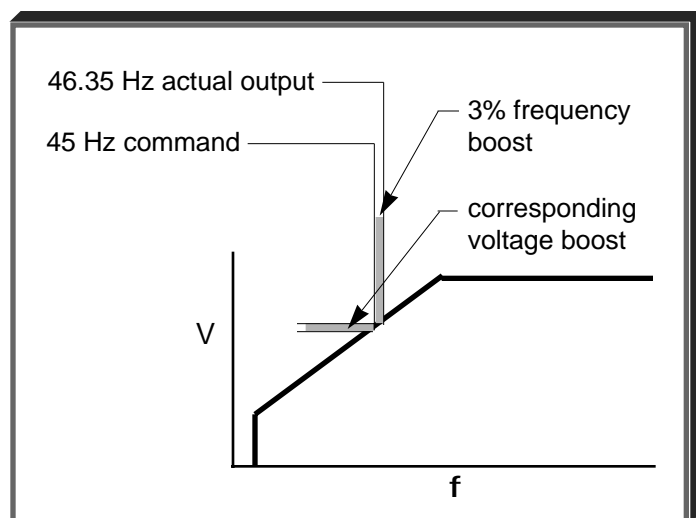

2.27 SOFT START (S-CURVE) CHARACTERISTICS

Sn-06: Operation Mode
Select 3

Digits 1 & 2 [**X X X X**] : Soft Start
Characteristics

Setting of these two digits determines the S-curve (starting) characteristics of the acceleration ramp.

- X X 0 0 = S-curve time of 0.2 seconds
- X X 0 1 = S-curve disabled
- X X 1 0 = S-curve time of 0.5 seconds
- X X 1 1 = S-curve time of 1.0 seconds

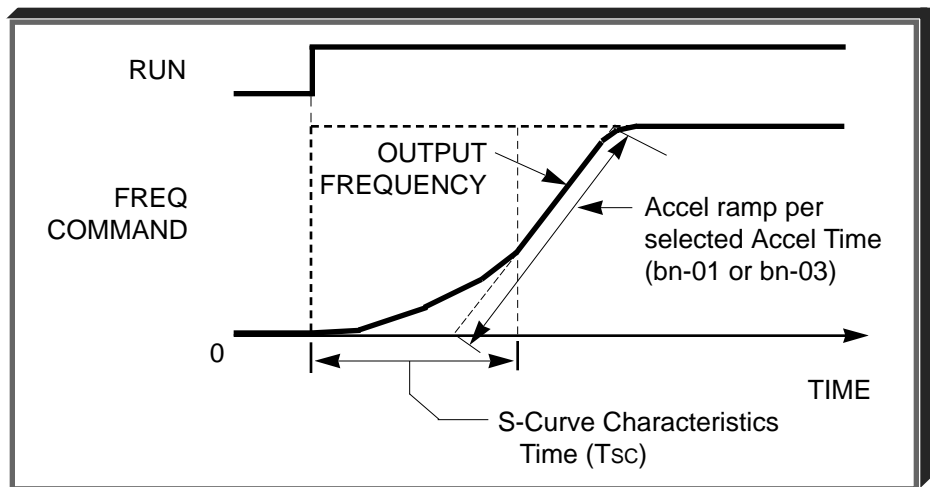

2.28 SPEED SEARCH

A. Sn-15 thru Sn-18: Multi-function Input Terminals

Data 61: Speed Search From Max Frequency
Data 62: Speed Search From Set Frequency

A multi-function input terminal is utilized to activate speed search. When the external speed search command is closed, the base is blocked for 0.5 second, then the speed search is made. The operation depends on the set value.

IMPORTANT

Set values **61** and **62** CANNOT be selected in combination.

- When **61** is set, the speed search begins with the maximum frequency.
- When **62** is set, the speed search begins with the frequency command that has been set after the search command was received.

2.28 SPEED SEARCH

Continued

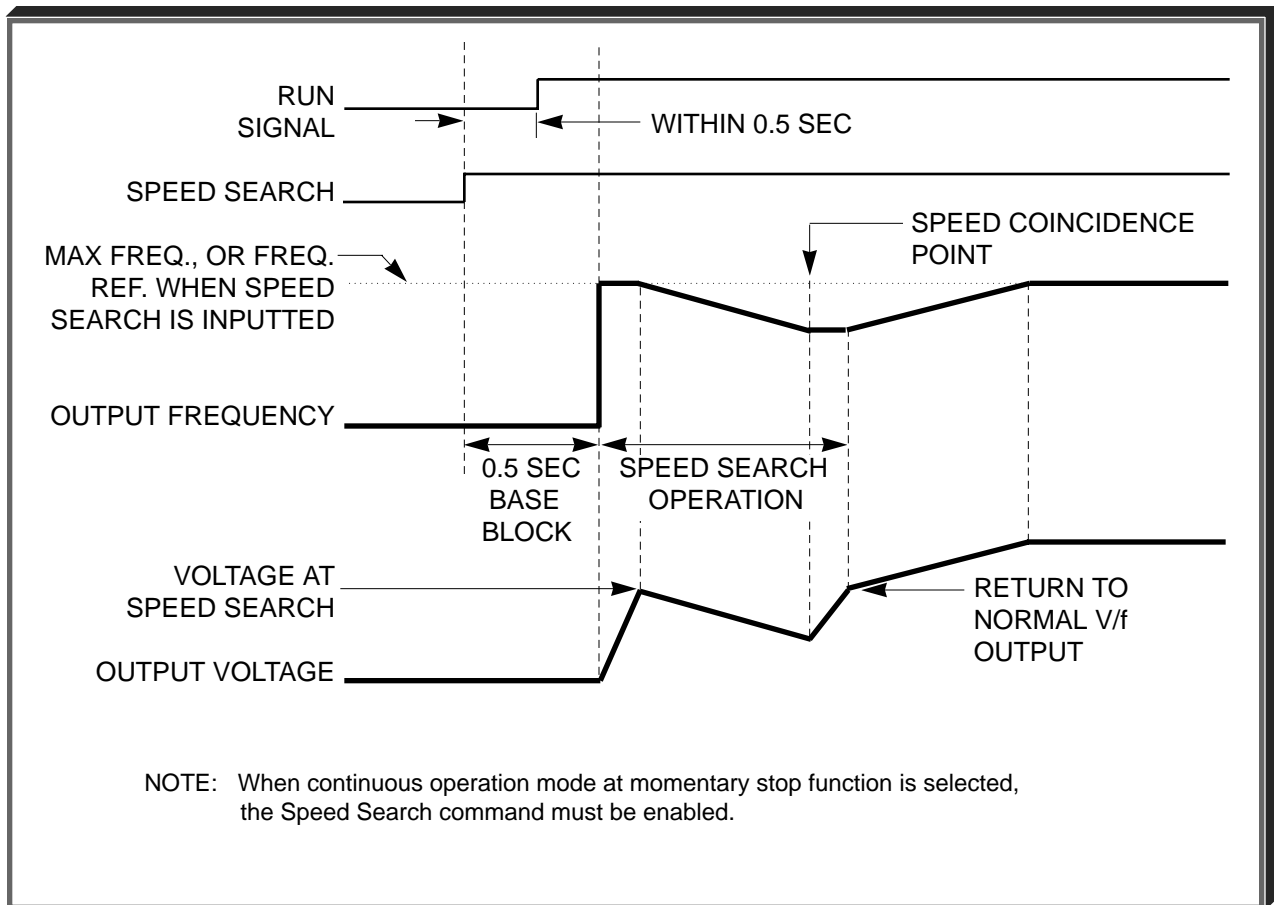
***Speed Search Operation Timing***

2.28 SPEED SEARCH

Continued

B. Cn-38: Speed Search Deactivation Current LevelFactory setting: **150 %**

Range: 0 to 200 %

After power recovery, if the GPD 503 output current is larger than the set value of Cn-38, speed search is started. When GPD 503 output current is lower than the set value of Cn-38, speed search is complete and acceleration or deceleration is continued to set frequency.

C. Cn-39: Speed Search Decel TimeFactory setting: **2.0 sec.**

Range: 0.0 to 25.5 sec.

This constant sets deceleration time during speed search, in units of 0.1 second. A setting of 0.0 seconds disables speed search.

D. Cn-40: Minimum Baseblock TimeFactory setting: GPD 503
rating dependent

Range: 0.0 to 25.5 sec.

When a momentary power loss is detected, the GPD 503 output transistors are disabled for a period of time determined by the setting of Cn-40. The Cn-40 setting should represent the time required for the motor residual voltage to go to zero.

When the time of the momentary power loss time exceeds the minimum baseblock time, the speed search operation is started immediately after power recovery.

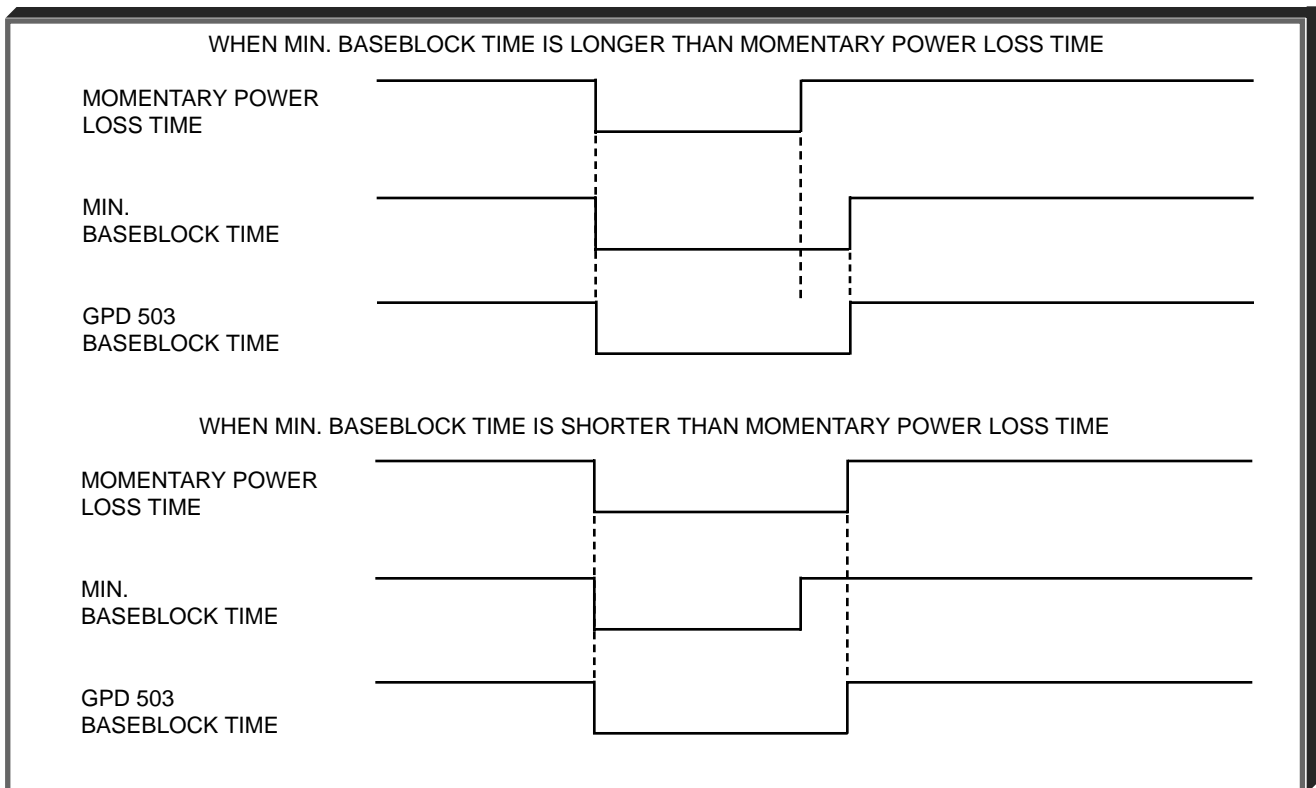

2.28 SPEED SEARCH Continued

E. Cn-41: V/f During Speed Search

Factory setting: 100 %

Range: 0 to 100 %

To prevent a fault such as OC from occurring during the speed search operation, V/f must be set to a value lower than that required during normal operation.

$$\text{V/f during speed search} = \text{V/f at normal operation} \times \text{Cn-41}$$

F. Cn-42: Voltage Recovery Time

Factory setting: 0.3 sec.

Range: 0.1 to 2.0 sec.

Sets the amount of time the drive needs to recover from zero to rated output voltage after speed search.

2.29 STALL PREVENTION

Sn-10: Protective Characteristics Select 1 (Stall Prevention)

The stall prevention characteristics determine whether stall prevention is enabled or disabled during the various operating modes, as well as selecting the decel rate during stall prevention.

Data: —	X X X 0	=	Stall prevention enabled during acceleration
—	X X X 1	=	Stall prevention disabled during acceleration
—	X X 0 X	=	Stall prevention enabled during deceleration
—	X X 1 X	=	Stall prevention disabled during deceleration
—	X 0 X X	=	Stall prevention enabled during operation at set frequency
—	X 1 X X	=	Stall prevention disabled during operation at set frequency
—	0 X X X	=	Decel time during stall prevention set by bn-02
—	1 X X X	=	Decel time during stall prevention set by bn-04

Cn-28: Stall Prevention Level During Acceleration (Constant Torque Region)

Factory setting: 170 %

Range: 30 to 200 %

Cn-29: Stall Prevention Limit During Acceleration (Constant HP Region)

Factory setting: 50 %

Range: 30 to 200 %

The stall prevention during acceleration extends the acceleration rate according to the load status with respect to the level programmed into Cn-28 or Cn-29 (based on GPD 503 rated current; see Table A3-1) and protects the motor from stalling during acceleration.

Cn-30: Stall Prevention Level During Operation at Set Frequency

Factory setting: 160 %

Range: 30 to 200 %

During operation while the speed is constant, if the GPD 503 output current exceeds the stall prevention level set into Cn-30, the output frequency is reduced to a level to prevent motor stalling. If the output current returns to a value lower than Cn-30, the output frequency returns to its previous level.

2.29 STALL PREVENTION Continued

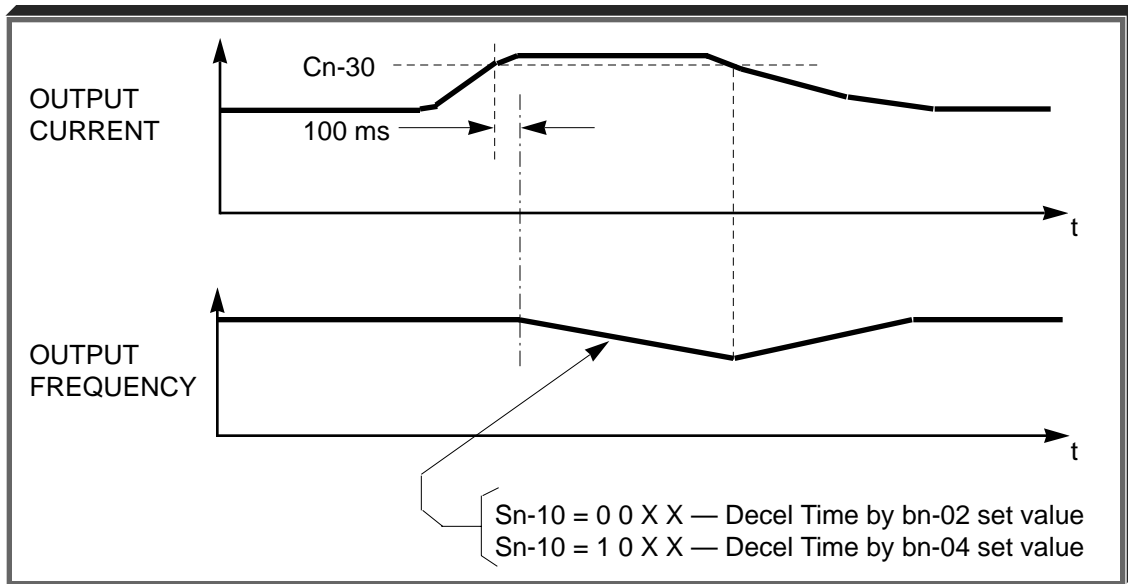

Stall Prevention Sequence at Set Frequency

Sn-19: Multi-function Analog Input (Term. 16)

Data 09: Stall Prevention Level During Running

The multi-function analog input at terminal 16 may be configured to allow analog control of the stall prevention level for operation at set frequency (from 0% to 100% of the level set in Cn-30).

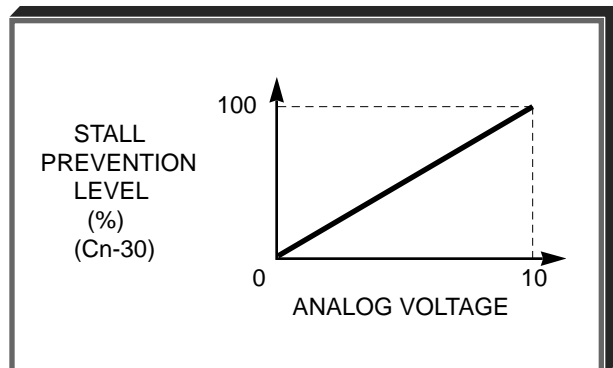
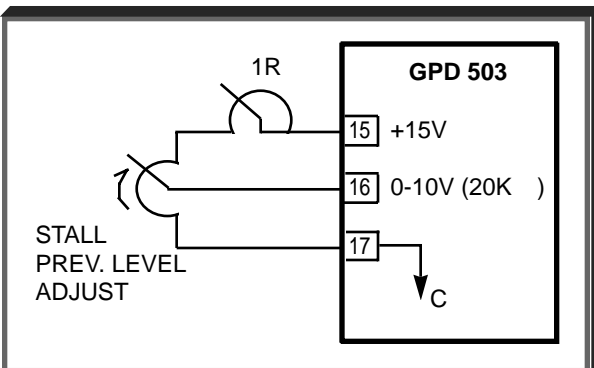

2.30 THERMAL MOTOR OVERLOAD PROTECTION

Sn-14: Protective Characteristics Select 5
(Motor Protection)

Factory Setting : **0000**

The GPD 503 Electronic Thermal Overload function meets standards set by UL and CSA for thermal motor overload protection.

Data: —	X X X 0	= Electronic thermal motor protection enabled
—	X X X 1	= Electronic thermal motor protection disabled
—	X X 0 X	= Electronic thermal protection for variable torque
—	X X 1 X	= Electronic thermal protection for constant torque
—	X 0 X X	= Short time rating disabled
—	X 1 X X	= Electronic thermal protection - short time rating enabled
* {	0 X X X	= Drive protection (OL2) operates at 150% for one minute
	1 X X X	= Drive protection (OL2) operates at 125% for one minute

The motor protection characteristics determine whether electronic thermal motor protection is enabled or disabled, what type of load it is for, and how the GPD 503 will react after motor overload is detected. The thermal overload trip point is the motor rated current value in Cn-09; see Table A3-1 for factory setting.

Electronic thermal overload is a software routine which monitors and protects the motor from an overtemperature condition over time.

The two considerations of the electronic overload routine are drive output current and time. Thus, the electronic overload trip curve is as shown at right.

There are in fact two overload fault conditions which the GPD 503 can detect, electronic thermal overload (OL1) and output overload (OL2). In reality, the GPD 503 will never output more than 200% rated output current without the output overload (OL2) tripping.

* Only selected versions make adjustment with this digit:

230V 40HP (CT) and above
460V 75HP (CT) and above
575V 30HP (CT) and above

2.30 THERMAL MOTOR OVERLOAD PROTECTION

Continued

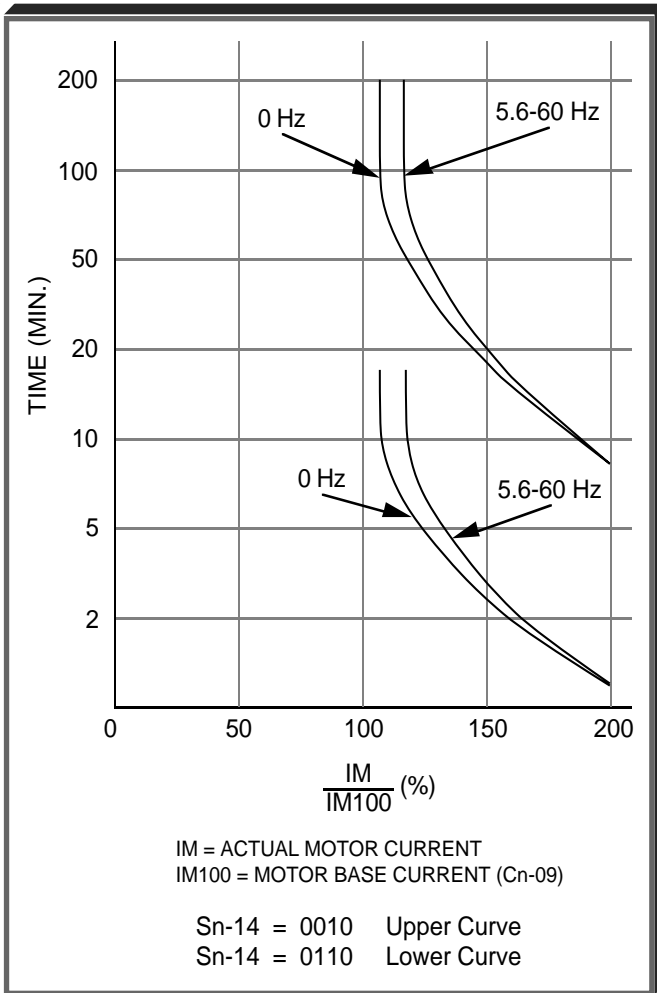

Electronic Motor Thermal Protection Characteristics For Constant Torque Motor

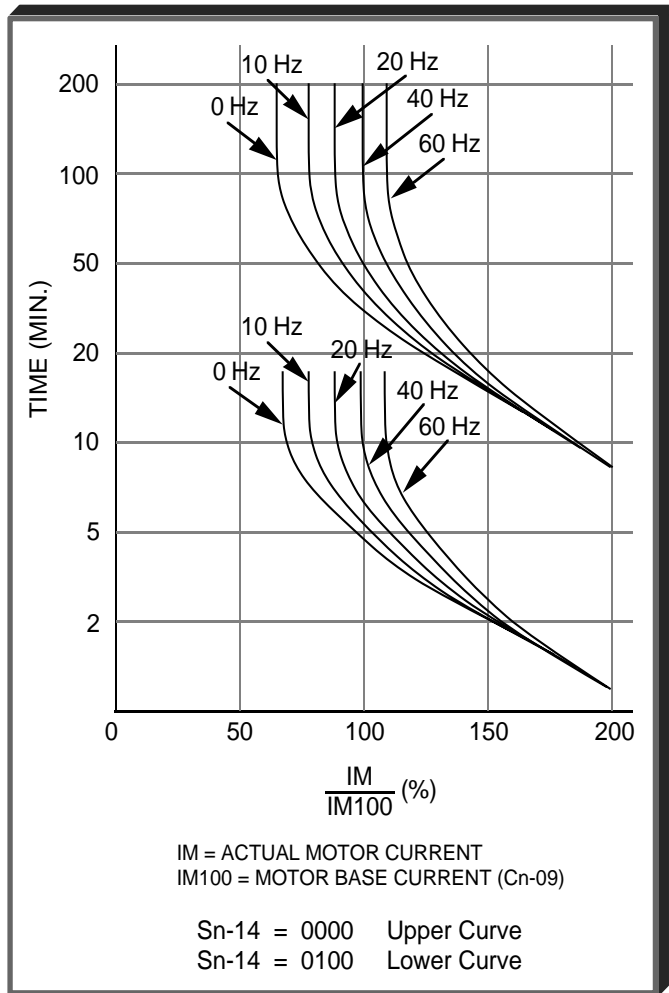

Electronic Motor Thermal Protection Characteristics For Variable Torque Motor

2.31 TORQUE COMPENSATION

bn-07: Torque Compensation Gain (K_T)

Factory setting: **1.0**

Range: 0.0 to 2.0

Sets the torque compensation, in increments of 0.1. When the motor has the same capacity as that of the GPD 503, the gain is 1.0. When a smaller motor is used, the gain should be set to 1.5 (typical).

This constant, in conjunction with Cn-31 (Motor-to-Motor Cable Resistance) and Cn-32 (Torque Compensation Iron Loss), is used by the drive's automatic torque boost function to match the drive's output voltage boost to the motor load. Except for the most demanding of high starting torque applications, the factory settings of these constants will be adequate. The factory settings are programmed to match the performance characteristics of typical AC motors.

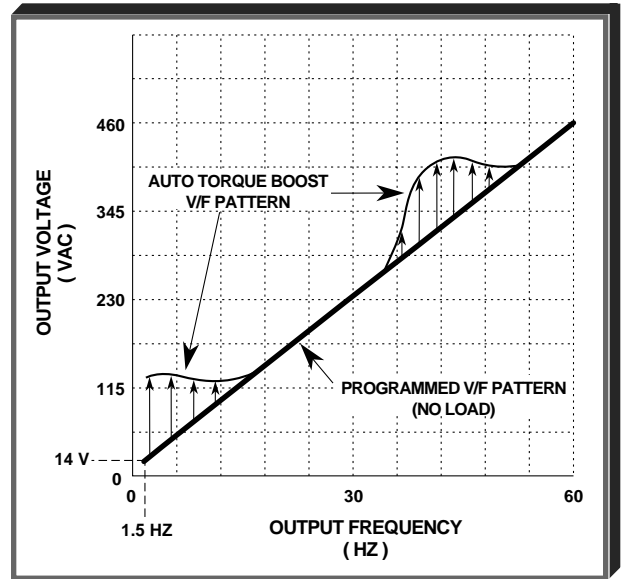

Example of Torque Compensation Operation

The calculation of compensated torque uses the following formula:

$$\text{Compensated Value} \approx \frac{(\sqrt{3} \cdot V_{ac} \cdot I_{ac} \cdot \cos \phi) - W_I - R_{cable}}{\text{Frequency}} \times K_T$$

Where

W_I = Cn-32

R_{cable} = Cn-31

K_t = bn-07

= Power Factor (calculated by the GPD 503)

2.32 V/f PATTERN - STANDARD

Sn-02: V/f Pattern

This system constant is factory preset to **01**. Table 2-4 describes 14 other preset patterns, one of which may be better suited for your specific application and load characteristics. However, if none of these patterns are suitable, this constant can be set to **0F** (V/f pattern - custom). The exact pattern is then defined by the settings of Cn-02 thru Cn-08, described in paragraph 2.33.

Table 2-4. Standard (Preset) V/f Patterns

APPLI-PATTERN		Sn-02	V/f PATTERN	APPLI-	Sn-02	V/f
G P E N E R A L	50Hz	00		H I G H T O R Q U E S T A R T I N G	50Hz	Starting Torque Low 08
	60Hz Saturation	01			Starting Torque High 09 	
	50Hz Saturation	02			60Hz	Starting Torque Low 0A
						Starting Torque High 0b
	72Hz	03		C O N S T A N T H O R S E P O W E R	90Hz	0C
V A R I A B L E *	50Hz	Starting Torque Low 04 	120Hz		0d 	
		Starting Torque High 05 				
	60Hz	Starting Torque Low 06 	180Hz	0E 		
		Starting Torque High 07 				

NOTES:

- * Consult MagnTek for assistance when these settings are desired.
- 1. The following conditions must be considered when selecting a V/f pattern:
 - Pattern matches the voltage-frequency characteristics of the motor.
 - Maximum motor speed.
- 2. V/f pattern for high starting torque should be selected for:
 - Wiring distance.
 - Large voltage drop at start.
 - AC reactor connected to GPD 503 input or output.
 - Use of motor rated below GPD 503 max. output.
- 3. Patterns shown are for 230V input; for other input, multiply all (V) values by $(V_{IN}/230)$.
 i.e., for 460V input, multiply by $460/230 = 2$; for 575v input, multiply by $575/230 = 2.5$.

2.33 V/f PATTERN - CUSTOM

A. Cn-01: Output Voltage Regulator

Factory Setting: **230/460/575 V**

Range: 0.0 to 255.0 (230V)

0.0 to 510.0 (460V)

0.0 to 733.1 (575V)

This constant sets the output voltage to be regulated. If Sn-02 is set to a value in the range **00** to **0E**, then changing Cn-01 will automatically effect the voltage constants (Cn-03, Cn-06 and Cn-08; see section B of this feature description) proportionally. If Sn-02 is **0F**, then Cn-01 has no effect on the voltage constants, and the output voltage would be determined by the voltages programmed into Cn-03, Cn-06 and Cn-08.

NOTE: Before changing Cn-01, refer to the examples below.

EXAMPLES:

230V Drive

V _{IN}	V _{OUT}	Cn-01
230	230	230 ← Factory Setting
230	208	208
208	208	208

460V Drive

V _{IN}	V _{OUT}	Cn-01
460	460	460 ← Factory Setting
460	400	400
380	380	380
460	380	460 *

* For this condition, Custom V/Hz Pattern should be used (Sn-02 = **0F**), and Cn-01 set to Input Voltage.

For 460V units only:

- If Cn-01 400, then overvoltage trip point = 800 Vdc
- If Cn-01 400, then overvoltage trip point = 700 Vdc.

575V Drive

V _{IN}	V _{OUT}	Cn-01
575	575	575 ← Factory Setting
500	500	500
575	500	575 *

* For this condition, Custom V/Hz Pattern should be used (Sn-02 = **0F**), and Cn-01 set to Input Voltage.

For 575V units only:

- If Cn-01 500, then overvoltage trip point = 1040 Vdc
- If Cn-01 500, then overvoltage trip point = 910 Vdc.

2.33 V/f PATTERN - CUSTOM

Continued

	Initial Voltage Values *	
	When Sn-02 = 01	When Sn-02 = 0F
B. Cn-02: Frequency – Max. (Fmax)		
Cn-03: Voltage – Max. (Vmax)	230.0 V	200.0 V
Cn-04: Frequency – Max. Voltage point (FA)		
Cn-05: Frequency – Midpoint (FB)		
Cn-06: Voltage – Midpoint (Vc)	17.2 V	15.0 V
Cn-07: Frequency – Min. (Fmin)		
Cn-08: Voltage – Min. (Vmin)	11.5 V	10.0 V

* Double indicated values for 460V units;
2.5 times indicated values for 575V units.

These seven control constants define the custom V/f pattern, **only if Sn-02 is set to 0F**. The illustration below shows how these constants relate to each other in establishing the custom V/f pattern.

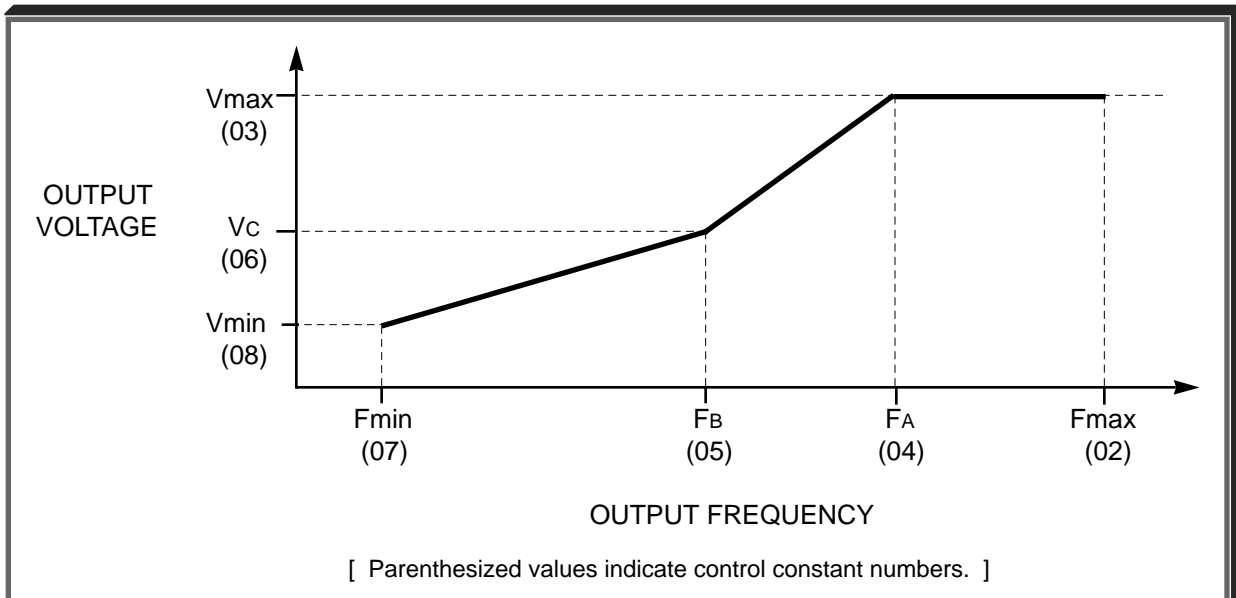

V/f Characteristics Set by Cn-02 thru Cn-08

NOTE: To establish a V/f pattern with a straight line from Fmin to FA, set FB = Fmin. The setting of Vc is then disregarded and does not affect the V/f pattern.

IMPORTANT

The constant settings are checked whenever power is applied to the GPD 503, or each time the **DATA/ENTER** key is pressed while in the Program (PRGM) mode. A constant set value failure (**oPE**) will occur if any part of the following relationships among Cn-02 thru Cn-08 is not TRUE:

- (a) $F_{max} \geq F_A \geq F_B \geq F_{min}$
- (b) $V_{max} > V_C \geq V_{min}$

2.34 UP/DOWN FREQUENCY SETTING

Sn-15 thru Sn-18: Multi-function Input
Terminals (Term. 5-8)

Data **10** : UP function
Data **11** : DOWN function

Programming data **10** and **11** for two of the four multi-function input terminals allows the inputs to be used for UP/DOWN frequency setting.

NOTES:

1. **oPE03** fault will occur if UP function and DOWN function data settings are not used together.
2. JOG has priority over UP/DOWN.
3. UP/DOWN has priority over Multi-step Speed inputs.
4. UP/DOWN is ineffective when operation is from the Digital Operator.
5. Upper and lower limit speeds set by Cn-02, Cn-14 and Cn-15.

EXAMPLE:

Sn-17 Data **10** : UP function
Sn-18 Data **11** : DOWN function

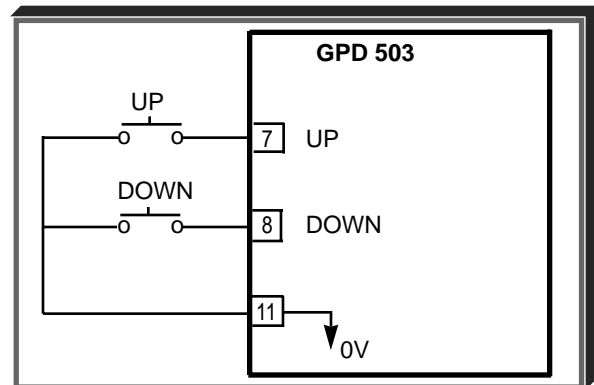

INPUT SIGNAL		FUNCTION
UP	DOWN	
Open	Open	HOLD
Closed	Open	UP (Frequency command approaches frequency command upper limit)
Open	Closed	DOWN (Frequency command approaches minimum output frequency or frequency command lower limit, whichever is larger)
Closed	Closed	HOLD

2.34 UP/DOWN FREQUENCY SETTING

Continued

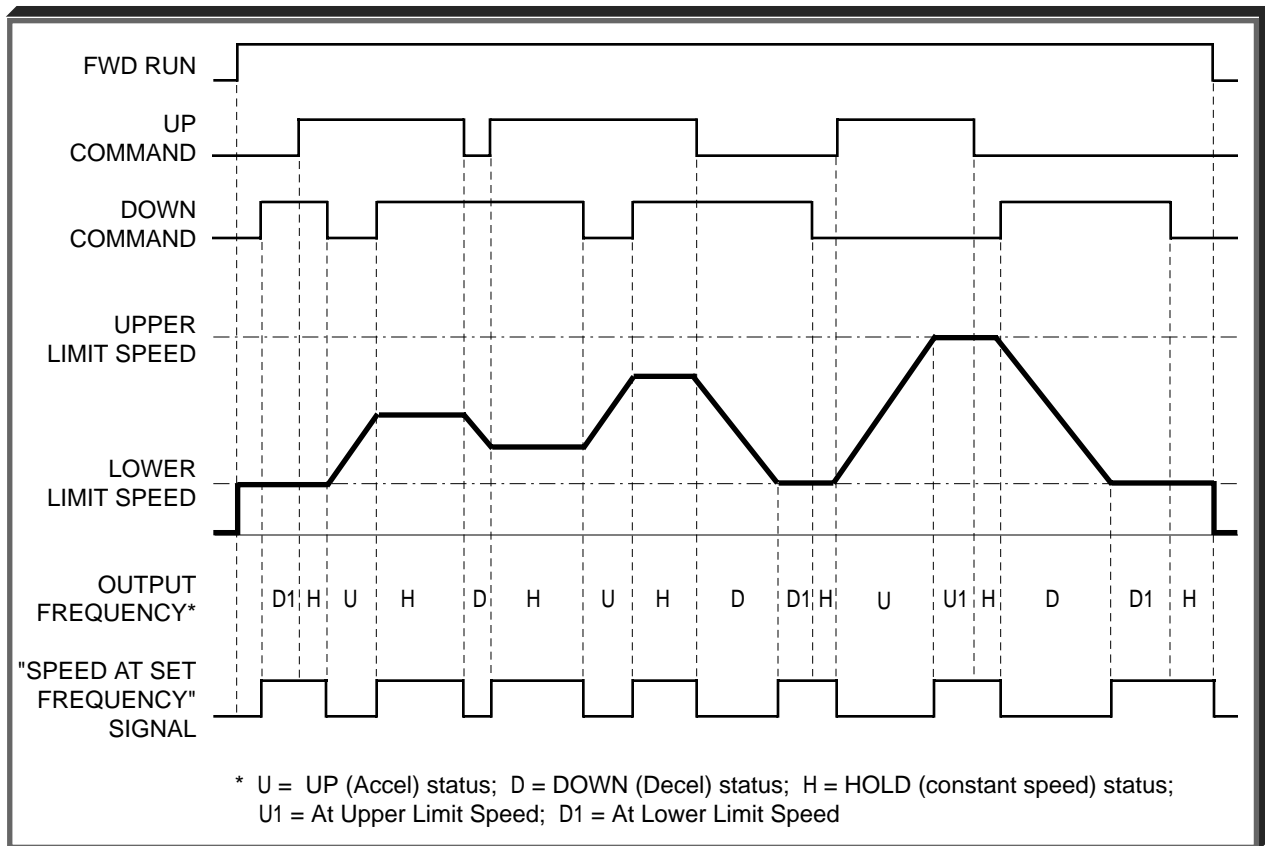

Up/Down Frequency Setting Timing

2.35 SLIP COMPENSATION DELAY TIME

Cn-35: Slip Compensation Delay Time

Factory Setting: **2.0** seconds

Range: 0.0 to 25.5 seconds

Set in increments of 0.1 second. When the output current of the drive becomes equal to the motor rated current (Cn-09), the output frequency of the drive is compensated for by the motor rated slip. The amount of frequency compensation is determined by the following formula. If frequency reference is equal to or smaller than minimum output frequency (Cn-07), slip compensation is not performed.

$$\text{Amount of output freq. comp.} = \frac{\text{bn-08}}{\text{Cn-09} - \text{Cn-34}} \times (\text{Output current} - \text{Cn-34})$$

Where:

Cn-09 = Motor Rated Current

Cn-34 = Motor No-load Slip

bn-08 = Motor Rated Slip

2.36 CARRIER FREQUENCY

Cn-23: Carrier Frequency Upper Limit

Cn-24: Carrier Frequency Lower Limit

Cn-25: Frequency Proportion Gain

Factory Setting: <i>See Table 2-5</i>
Range (Each): 0.4 to 15.0 kHz
Factory setting: <i>See Table 2-5</i>
Range: 0 to 99

The relationship between output frequency and carrier frequency is determined from the set values of Cn-23 to Cn-25.

(a) For constant carrier frequency (set value of Cn-23):

Set Cn-25 to 0, and set the same value in both Cn-23 and Cn-24.

(b) For synchronous mode (only with proportional section):

Set Cn-25 to 12, 24, 36 or 48. These setting values establish carrier frequencies of 12f, 24f, 36f, or 48f, respectively.

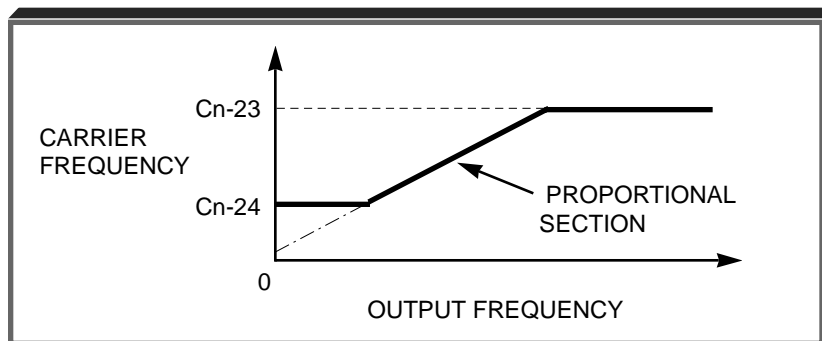

NOTE: Fault code ***oPE11*** is displayed if either of the following conditions is detected:

1. $Cn-25 > 6 \text{ kHz}$, and $Cn-24 > Cn-23$
2. $Cn-23 > 5 \text{ kHz}$, and $Cn-24 \leq 5 \text{ kHz}$.

2.36 CARRIER FREQUENCY Continued

Table 2-5. Factory Settings of Carrier Frequency Constants

CT HP	Drive Model No.	Cn-23	Cn-24	Cn-25	CT HP	Drive Model No.	Cn-23	Cn-24	Cn-25
230 V									
1	DS305	15.0	15.0	0	40	DS2040	2.0	0.4	36
2	DS302	15.0	15.0	0	40/50	GPD503-2L40	10.0	10.0	0
3	DS306	15.0	15.0	0	50	DS2050	2.0	0.4	36
5	DS307	15.0	15.0	0	60	GPD503-2L50	10.0	10.0	0
7.5	DS308	15.0	15.0	0	60	DS2060	2.5	1.0	36
10	DS309	15.0	15.0	0	60	GPD503-2L60	10.0	10.0	0
15	DS310	15.0	15.0	0	75	DS2075	2.5	1.0	36
20	DS311	15.0	15.0	0	75	GPD503-2L75	10.0	10.0	0
25	DS322	15.0	15.0	0	100	DS2100	2.5	1.0	36
30	DS323	15.0	15.0	0	100	GPD503-2L100	10.0	10.0	0
460 V									
1	DS313	15.0	15.0	0	60	DS360	10.0	10.0	0
2	DS304	15.0	15.0	0	75	DS075	2.5	1.0	36
3	DS314	15.0	15.0	0	75/100	GPD503-4L75	10.0	10.0	0
5	DS315	15.0	15.0	0	100	DS100	2.5	1.0	36
7.5	DS316	15.0	15.0	0	100	GPD503-4L100	10.0	10.0	0
10	DS317	15.0	15.0	0	150	DS150	2.5	1.0	36
15	DS318	15.0	15.0	0	150	GPD503-4L150	10.0	10.0	0
20	DS326	15.0	15.0	0	200	DS200	2.5	1.0	36
25	DS325	15.0	15.0	0	200	GPD503-4L200	10.0	10.0	0
30	DS330	15.0	15.0	0	250	DS250	2.5	1.0	36
40	DS340	15.0	15.0	0	300	DS303	2.5	1.0	36
50	DS350	10.0	10.0	0	400	DS400	2.5	1.0	36
575 V									
2	DS5003	15.0	15.0	0	40	DS5043	10.0	10.0	0
3	DS5004	15.0	15.0	0	50	DS5054	10.0	10.0	0
5	DS5006	15.0	15.0	0	60	DS5064	10.0	10.0	0
7.5	DS5009	15.0	15.0	0	75	DS5081	10.0	10.0	0
10	DS5012	15.0	15.0	0	100	DS5112	2.0	1.0	36
15	DS5017	15.0	15.0	0	125	DS5130	2.0	1.0	36
20	DS5022	10.0	10.0	0	150	DS5172	2.0	1.0	36
25	DS5027	10.0	10.0	0	200	DS5202	2.0	1.0	36
30	DS5032	10.0	10.0	0					

Section 3. DIGITAL OPERATOR

3.1 GENERAL

The Digital Operator enables the GPD 503 to be operated in either the Drive (DRIVE) mode or the Program (PRGM) mode. The Program mode enables the operator to enter information into the GPD 503's memory to configure the GPD 503 to the application. In the Drive mode, the GPD 503 controls motor operation. Switching between the two modes can only be done when the GPD 503 is in a stopped condition.

3.2 DISPLAY AND KEYPAD

The Digital Operator has a 5 digit LED display. Both numeric and alphanumeric data can appear on the display, but because 7-segment LEDs are used, the number of alphabetic characters is limited.

Indicator lamps and keys on the Digital Operator are described in Table 3-1.

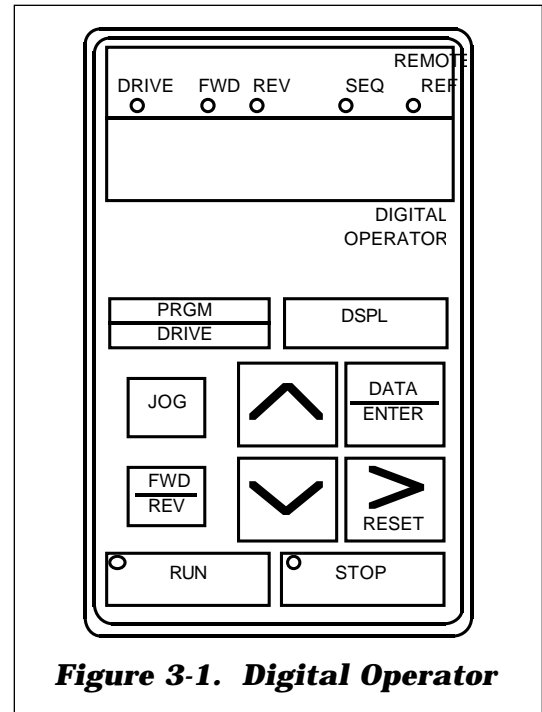

Figure 3-1. Digital Operator

Table 3-1. Digital Operator Controls

A. INDICATOR LAMPS	
NAME	FUNCTION
DRIVE	Lights when the GPD 503 is in the Drive mode of operation.
FWD	Lights when Forward motor run has been selected.
REV	Lights when Reverse motor run has been selected.
REMOTE SEQ	Lights when the GPD 503 is programmed to operate from external RUN and STOP signals.
REMOTE REF	Lights when the GPD 503 is programmed to operate by an external frequency reference signal.
RUN	Off when GPD 503 is in stopped condition; lights steadily when Run signal is active; blinks after Stop signal has been received and GPD 503 output is ramping down. (See Figure 3-2.)
STOP	Lights steadily at initial power-up; blinks after Run signal becomes active but frequency reference is zero; off when GPD 503 output is controlling motor speed. (See Figure 3-2.)

Table 3-1. Digital Operator Controls - Continued

B. KEYPAD KEYS	
LABEL	FUNCTION
<u>PRGM</u> DRIVE	Pressing this key toggles between the Drive and Program modes of operation. Active only when the GPD 503 is in stopped condition.
JOG	IN DRIVE MODE: Pressing and holding this key will initiate Jog function: GPD 503 output goes to programmed Jog Frequency to check motor operation, or to position machine. When key is released, output returns to zero and motor stops. If the motor is already running, pressing this key will have no effect. NOTE: Disabled if the GPD 503 is programmed to use an external JOG input.
<u>FWD</u> <u>REV</u>	IN DRIVE MODE: Each press of this key will toggle between Forward and Reverse motor run direction. The selected direction is indicated by the FWD or REV lamp being lit. If the selection is made while the GPD 503 is stopped, it determines the direction the motor will run when started. If the selection is changed during running, the GPD 503 will ramp the motor to zero speed and then ramp it up to set speed in the opposite (i.e. newly selected) direction.
RUN	IN DRIVE MODE: If the GPD 503 is not programmed to operate by external RUN and STOP signals (as indicated by REMOTE SEQ lamp being lighted), pressing this key will produce a Run command to initiate GPD 503 output to the motor. However, output frequency will be zero if the frequency reference is zero at the time this key is pressed.
STOP	IN DRIVE MODE: Pressing this key will produce a Stop command. The GPD 503 will decelerate the motor in the programmed stopping manner, then GPD 503 output will be disconnected from the motor.
DSPL	IN DRIVE MODE: Each press of this key will change the display to the next displayable parameter type available for the Drive mode. (Also see description of > key.) IN PROGRAM MODE: Each press of this key will change the display to the <i>first</i> available constant number in the <i>next</i> list of constants (An-, bn-, Sn- or Cn-).
<u>DATA</u> <u>ENTER</u>	IN DRIVE MODE OR PROGRAM MODE: When a constant number is being displayed, pressing this key will display the constant's set value presently in the GPD 503 memory. IN PROGRAM MODE ONLY: After the displayed set value has been changed as desired, pressing this key will write the new set value into GPD 503 memory to replace the old value.

Table 3-1. Digital Operator Controls - Continued

B. KEYPAD KEYS - Continued	
LABEL	FUNCTION
<p>> RESET</p>	<p>IN DRIVE MODE OR PROGRAM MODE: When a changeable constant setting value is being displayed, pressing this key moves the blinking (i.e. "changeable") position to the next digit to the right. If at the right-most position, this will wrap-around to the first "changeable" position on the left side of the display.</p> <p>IN DRIVE MODE ONLY: When a GPD 503 fault has occurred, pressing this key will reset the fault circuit in the GPD 503. Pressing this key along with the DSPL key will allow access to the Sn- and Cn- constants lists (for READING ONLY of the constant settings).</p>
<p>^</p>	<p>IN DRIVE MODE OR PROGRAM MODE: Pressing this key will increase the value of the blinking digit in the display by 1. Increasing stops at the value of 9, or F. Pressing this key will scroll up by 1 within a constants list.</p>
<p>v</p>	<p>IN DRIVE MODE OR PROGRAM MODE: Pressing this key will decrease the value of the blinking digit in the display by 1. Decreasing stops at the value of 0. Pressing this key will scroll down by 1 within a constants list.</p>

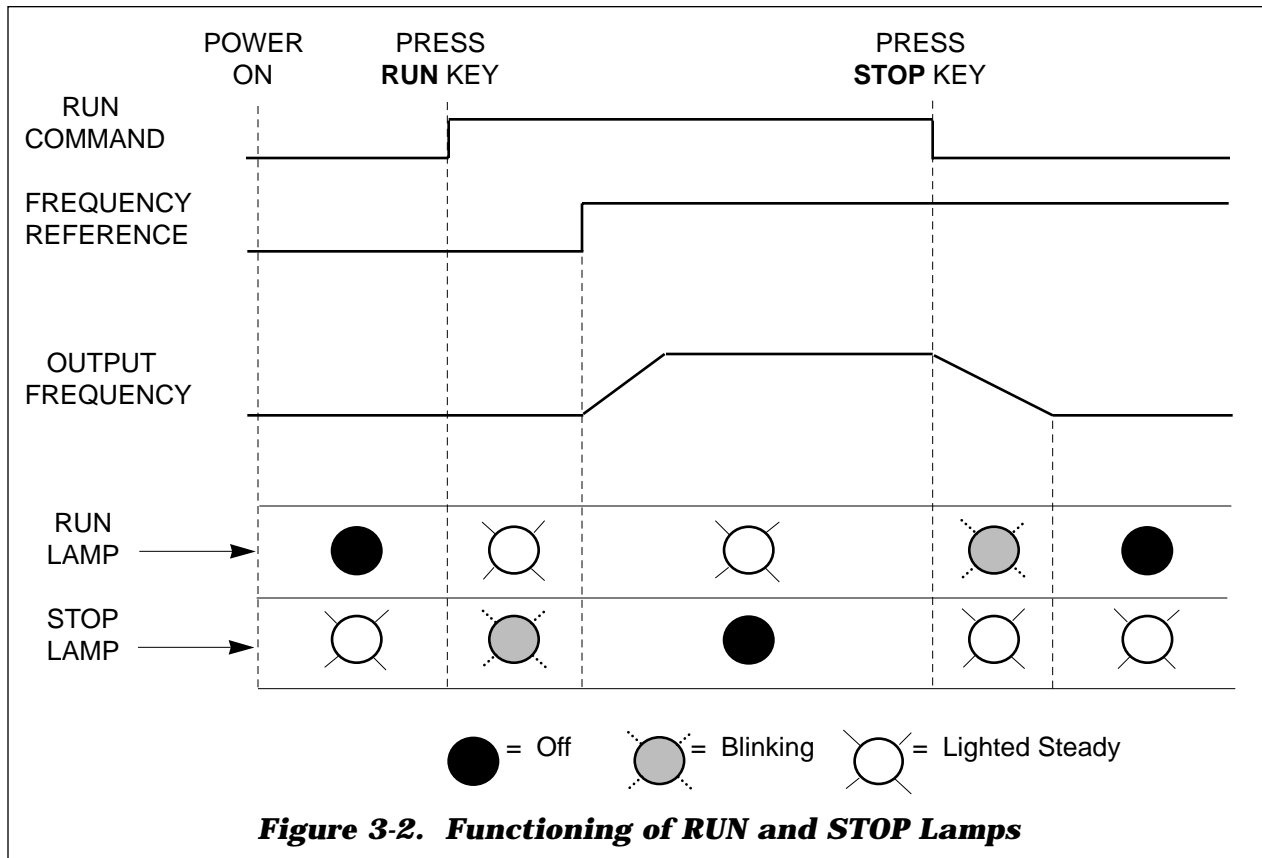

3.3 COMPARISON OF PROGRAM MODE AND DRIVE MODE

Displays that appear on the Digital Operator differ according to the selected mode of operation. The **PRGM** (Program) mode is used to change constant settings in the Drive's memory to configure it to the requirements of the application. The **DRIVE** mode is used primarily to control (i.e. start and stop) Drive output for motor/machine operation. The only constants that can be changed while in the **DRIVE** mode (An- or bn- settings, or Un-display selection) are those that will not have a critical effect on operating characteristics.

The constant group to be displayed, in either mode, is selected by pressing the **DSPL** key.

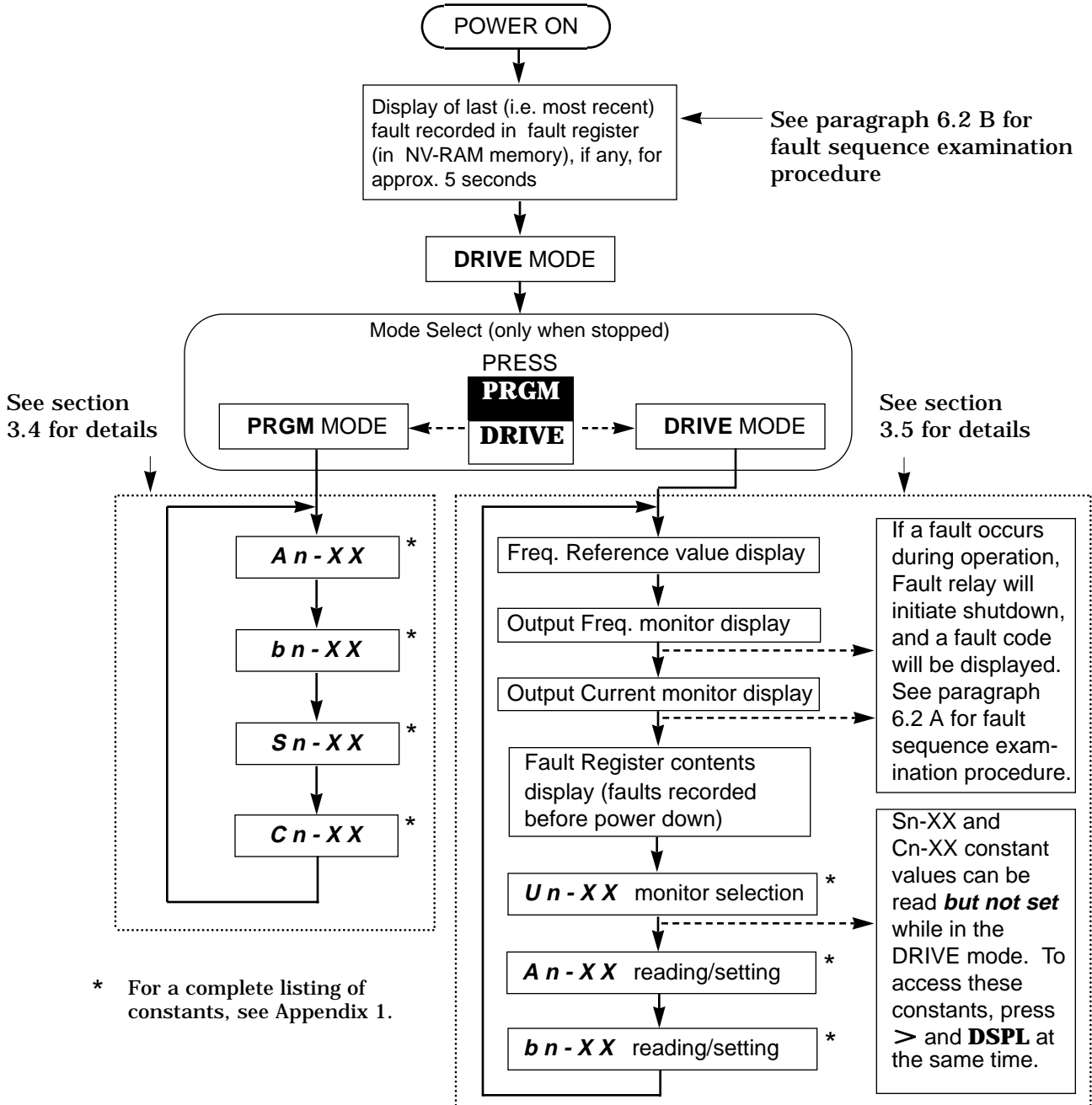

3.4 PROGRAM MODE OPERATION

A. Changing Display With DSPL Key:

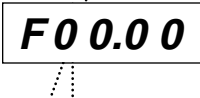
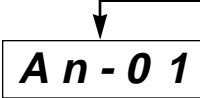
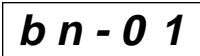
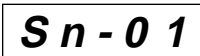
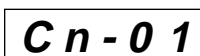
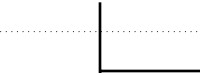
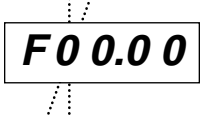
ACTION	DESCRIPTION	DISPLAY
Apply Power	<p>DRIVE lamp is on.</p> <p>— If the GPD 503 fault circuit detects a fault, a blinking Fault code will be displayed for 5 seconds.</p> <p>— Then the Frequency Reference (An-01) setting display appears.</p>	
Press PRGM Key DRIVE to Select Program Mode	<p>DRIVE lamp turns off. Display changes to first Frequency Reference Memory Settings constant number. (See next page for changing settings.)</p>	
Press DSPL Key	<p>Display changes to first Run Operative Settings constant number. (See next page for changing settings.)</p>	
Press DSPL Key	<p>Display changes to first System Constants number. (See next page for changing settings.)</p>	
Press DSPL Key	<p>Display changes to first Control Constants number. (See next page for changing settings.)</p>	
Press DSPL Key	<p>Cycle begins again with first Frequency Reference Memory Settings constant number.</p>	
After All Programming is Completed, Press PRGM Key DRIVE to Return to Drive Mode	<p>DRIVE lamp lights. Display shows the Frequency Reference (An-01) setting.</p>	

3.4 PROGRAM MODE OPERATION



Continued

B. Procedure For Changing a Setting:

ACTION	DESCRIPTION	DISPLAY
Press \wedge and \vee Keys as Necessary Until Display Shows Desired Constant No.	Value of <i>bn-XX</i> digits scrolls up or down by 1 each time one of these keys is pressed. EXAMPLE: Select bn-03, Accel. Time 2.	<i>bn - 0 3</i>
Press <u>DATA</u> <u>ENTER</u> Key to Display Current Setting	Display shows the value currently stored in memory for the constant. NOTE: Factory setting for bn-03 is <i>10.0</i> sec.	<i>1 0.0</i>
Press $>$, \wedge and \vee Keys as Necessary Until Display Shows Desired Setting	Blinking position of display shifts to the left. Value of blinking digit increases or decreases when keys are pressed. EXAMPLE: Set bn-03 to <i>16.0</i> sec.	<i>1 6.0</i>
Press <u>DATA</u> <u>ENTER</u> to Store New Setting	Display lights steady for a short time, then <i>End</i> is displayed for approx. 1 sec. Then setting is displayed again, with one digit blinking. NOTE: If the setting being entered is not within acceptable range for the selected constant, the fault indication " <i>Err</i> " will appear instead of " <i>End</i> " (the new setting was not written into EPROM memory); then the display again shows the value currently stored in memory.	<div style="display: flex; flex-direction: column; align-items: center;"> <div style="border: 1px solid black; padding: 2px 10px;"><i>1 6.0</i></div> <div style="margin: 5px 0;">↓</div> <div style="border: 1px solid black; padding: 2px 10px;"><i>End</i></div> <div style="margin: 5px 0;">↓</div> <div style="border: 1px solid black; padding: 2px 10px;"><i>1 6.0</i></div> </div>
Press DSPL Key to Return to Setting Number Selection	Display returns to beginning of cycle for selection of setting number to be programmed (see preceding page).	<i>bn - 0 3</i>

3.5 DRIVE MODE OPERATION

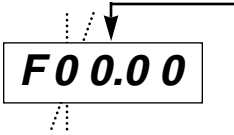
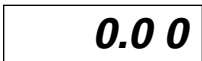
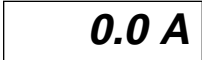
A. Changing Display With DSPL Key:

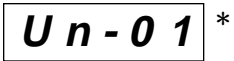
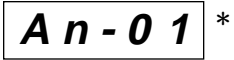
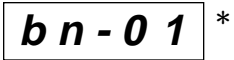

<u>ACTION</u>	<u>DESCRIPTION</u>	<u>DISPLAY</u>
Apply Power	<p>DRIVE lamp is on.</p> <p>— If the GPD 503 fault circuit detects a fault, a blinking Fault code will be displayed for 5 seconds.</p> <p>— Then the Frequency Reference (An-01) value appears.</p>	
Press DSPL Key	Display changes to present Output Frequency value.	
Press DSPL Key	Display changes to present Output Current value.	
Press DSPL Key	<p>Display changes to last Fault code. (If no fault has occurred, cycle skips to next display). EXAMPLE:</p>	 <p>Main Circuit UV Trip</p>
Press DSPL Key	Display changes to first Monitor Displays number.	
Press DSPL Key	Display changes to first Frequency Reference Memory Settings constant number.	
Press DSPL Key	Display changes to first Run Operative Settings constant number.	
Press DSPL Key	Cycle begins again with Frequency Reference display.	

* Use ^ key to step through the list of constants, and **DATA** key to display An- or bn- set value, or information called for by Un- constant.

3.5 DRIVE MODE OPERATION

Continued

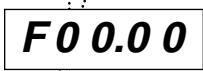
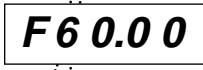
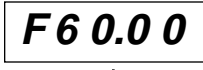
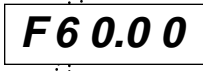
B. Drive Operation From Digital Operator (Using Factory Settings):

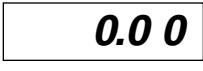
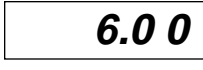
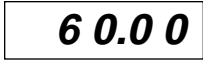
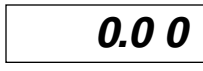
<u>ACTION</u>	<u>DESCRIPTION</u>	<u>DISPLAY</u>
Apply Power	DRIVE lamp is on. The Frequency Reference (An-01) set value appears.	
Use > , ^ , and v Keys as Necessary Until Display Shows Desired Run Frequency	Blinking position of display shifts to the left. Value of blinking digit increases or decreases when keys are pressed.	
Press <u>DATA</u> Key <u>ENTER</u> To Write New Value Into Memory	Displayed value stops blinking for approximately 2 seconds, then digit resumes blinking.	 ↓ 
Press <u>FWD</u> Key <u>REV</u> To Select Desired Direction of Motor Rotation	Observe FWD and REV indicator lamps on Digital Operator to see which direction motor will rotate when GPD 503 is started.	FWD REV  EXAMPLE: FWD Run selected
Press DSPL Key	Present Output Frequency is displayed.	
Press and Hold JOG Key	Check motor operation at programmed Jog Frequency operating speed.	
Release JOG Key; Press RUN Key	GPD 503 output increases to Frequency Reference level, at programmed Accel Rate. Motor speed increases accordingly.	
Press STOP Key	Motor speed decreases under GPD 503 control, at preset deceleration rate, to zero. Motor remains stopped.	

3.5 DRIVE MODE OPERATION

Continued

C. Drive Operation (2-Wire Control) By External Input Signals:

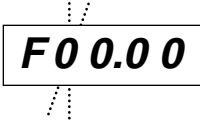
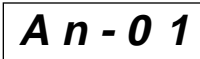
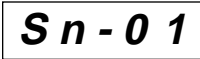
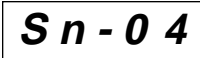
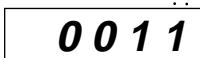
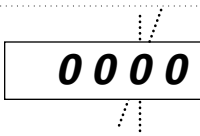
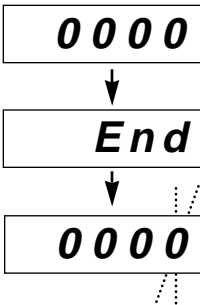
<u>ACTION</u>	<u>DESCRIPTION</u>	<u>DISPLAY</u>
Apply Power	<p>DRIVE lamp is on.</p> <p>The Frequency Reference (An-01) set value appears.</p> <p>NOTE: If the GPD 503 has already been programmed for operation by external signal input, frequency display will be as shown at "...Return to Drive Mode" action on next page; then continue at "Set Auto/Manual..." action.</p>	
Press PRGM Key to Select Program Mode	<p>DRIVE lamp turns off. First Frequency Reference Memory Settings constant number is displayed.</p>	
Press DSPL Key Twice	<p>First System Constants number is displayed.</p>	
Use ^ and v Keys as Necessary Until Display Shows Sn-04	<p>Value of Sn-XX digits scrolls up or down by 1 each time one of these keys is pressed.</p>	
Press DATA ENTER Key to Display Current Setting	<p>The value currently stored in memory for the constant is displayed.</p> <p>NOTE: Factory setting for Sn-04 is 0011, selecting An-01 as frequency reference, and Jog, Run and Stop by Digital Operator</p>	
Press > , ^ and v Keys as Necessary Until Display Shows 0000	<p>Blinking position of display shifts to the left. Value of blinking digit increases or decreases when keys are pressed.</p>	
Press DATA ENTER Key To Write New Setting of Sn-04 Into Memory	<p>Display lights steady for a short time, then End is displayed for approx. 1 sec. Then setting is displayed again, with one digit blinking.</p> <p>NOTE: With Sn-04 set to 0000, frequency reference is by external signal input, and Jog, Run and Stop are by external command inputs.</p>	

(Sequence continues on next page)

3.5 DRIVE MODE OPERATION

Continued

C. Drive Operation (2-Wire Control) By External Input Signals - Continued:

<u>ACTION</u>	<u>DESCRIPTION</u>	<u>DISPLAY</u>
Press PRGM Key DRIVE to Return to Drive Mode	DRIVE lamp lights. Display shows the Frequency Reference value as set by input at terminal 13, 14, or 16, ref. terminal 17.	F 0 0 . 0 0 (no digit blinking)
Set Auto/Manual Switch, If Used, To Select Desired External Reference Signal	Display shows frequency reference commanded by the present level of the input signal.	F 0 0 . 0 0 (no digit blinking)
Adjust External Speed Reference To Desired Level	Observe display as speed reference is adjusted. Stop when display shows desired output frequency. EXAMPLE: Adjust for 60Hz output.	F 6 0 . 0 0 (no digit blinking)
Press DSPL Key to Show Present Output Frequency	Present Output Frequency is displayed.	0 . 0 0
Close Contact at Terminals 7 & 11 To Jog Motor	Check motor operation at programmed Jog Frequency operating speed.	6 . 0 0
Close Contact at Terminals 1 & 11 To Perform Forward Run	GPD 503 output increases to Frequency Reference level, at programmed Accel Rate. Motor speed increases accordingly.	6 0 . 0 0
Open Contact at Terminals 1 & 11 To Stop Drive	Motor speed decreases under GPD 503 control, at preset Decel Rate, to zero.	0 . 0 0

Section 4. INITIAL START-UP (“LOCAL” CONTROL)

4.1 PRE-POWER CHECKS

- Verify wires are properly connected and no erroneous grounds exist.
- Remove all debris removed from the GPD 503 enclosure. Check for loose wire clippings.
- Verify all mechanical connections inside the GPD 503 are tight.
- Verify motor is not connected to load.
- *For 460V, 15HP (CT) and above only.* Verify that the GPD 503 power voltage select connector, located at lower left corner inside drive chassis (see Figure 4-1, A), is positioned correctly for the input power line voltage. Voltage is preset to 460V at the factory. Reposition, if required, to match nominal line voltage.
- *For 575V, 15HP and above only.* Verify the GPD 503 power voltage select connector (see Figure 4-1, B) is positioned correctly for the input power line voltage. Voltage is preset to 575/600V at the factory. Reposition if required.

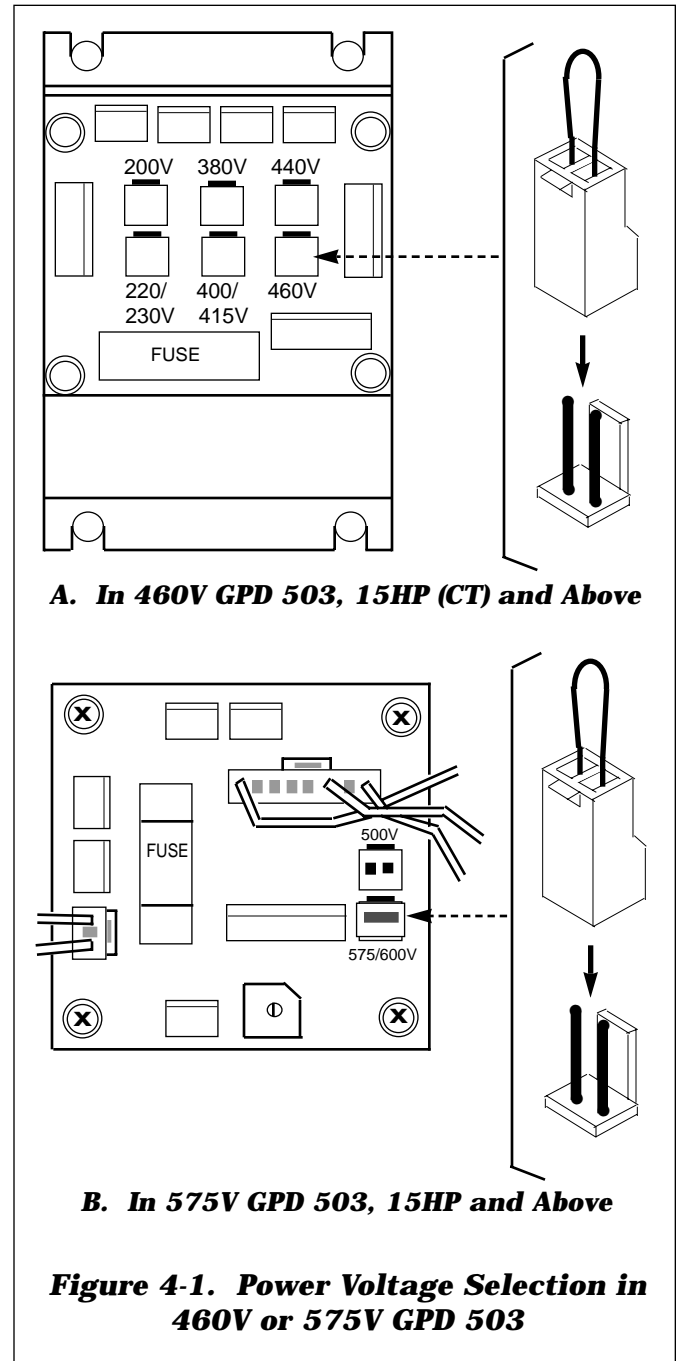

4.2 TEST RUN USING DIGITAL OPERATOR ("LOCAL" CONTROL)

The operation described in Table 4-1 and shown in Figure 4-2 is for a standard 60 Hz motor.

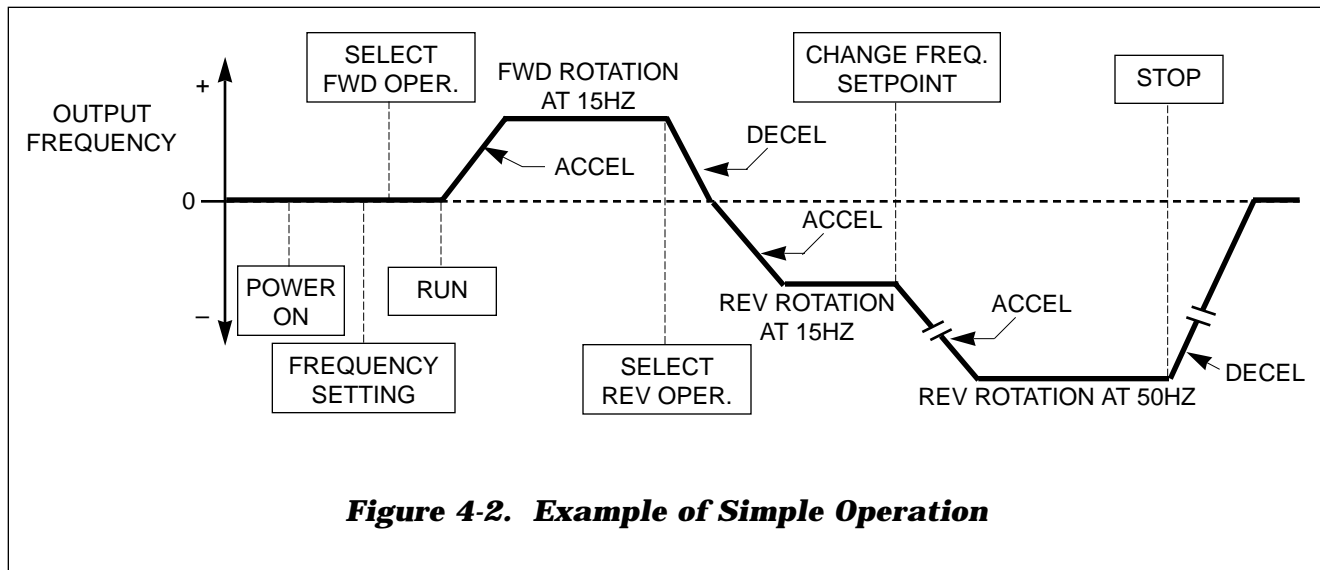

Table 4-1. Test Run With Digital Operator

OPERATING PROCEDURE	OPERATION AT DIGITAL OPERATOR	DIGITAL DISPLAY	DESCRIPTION
Power On	Red lamp at STOP key lights. (REMOTE lamp remains off).	 blinking for 5 seconds, then last selected monitor display (see below).	When power is applied, the last display before power off is indicated.
Frequency Setting	Select Drive mode by using PRGM/DRIVE key. Red DRIVE lamp lights. Press DSPL key, as necessary, until frequency command is displayed.	Frequency command Output frequency Output current Previous fault Repetition	GPD 503 is ready for controlling motor operation. Monitor function display selection. *See "DISPLAYING FAULT SEQUENCE" in Section 6.
	(Procedure continued on next page)		

Table 4-1. Test Run With Digital Operator - Continued



OPERATING PROCEDURE	OPERATION AT DIGITAL OPERATOR	DIGITAL DISPLAY	DESCRIPTION
<p>Frequency Setting (Continued)</p>	<p>EXAMPLE: Set frequency command to 15 Hz:</p> <p>Move to the setting digit by using > and make the setting with ^ and v.</p> <p>Store the frequency command value with DATA/ENTR key. (This data is stored even when the power is off).</p> <p>Press DSPL key once to change display to monitor output frequency.</p>		<p>Initial setting becomes frequency command.</p>
<p>Select Forward Operation</p>	<p>Select the rotation of motor with FWD/REV key. (Red FWD lamp lights).</p>		<p>GPD 503 is set for forward motor operation, but is still in "stopped" condition.</p>
<p>Run</p>	<p>Press RUN key. (Red lamp lights. Red lamp at STOP key goes off).</p>	 <p>(Display of current value of output frequency)</p>	<p>GPD 503 output and motor speed increase smoothly at preset acceleration rate, then hold steady at 15 Hz.</p>
<p>Select Reverse Operation</p>	<p>Press FWD/REV key. (Red FWD lamp goes off, and red REV lamp lights).</p>		<p>GPD 503 output (and motor speed) decreases smoothly, at preset deceleration rate, to zero.</p> <p>Then motor begins rotation in reverse direction, accelerating smoothly, then holds steady at 15 Hz.</p>
<p>Change Frequency Setpoint</p>	<p>Press DSPL key repeatedly until frequency command is again displayed.</p> <p>EXAMPLE: Set 50 Hz as new value of frequency command.</p> <p>Change the frequency set point by using >, ^ and v.</p> <p>(Procedure continued on next page)</p>		<p>Motor continues running at 15 Hz.</p> <p>Motor continues running at 15 Hz.</p>

Table 4-1. Test Run With Digital Operator - Continued

OPERATING PROCEDURE	OPERATION AT DIGITAL OPERATOR	DIGITAL DISPLAY	DESCRIPTION
Change Frequency Setpoint (Continued)	Store frequency command value by DATA/ENTR key. Press DSPL key once to change display to monitor output frequency.	 	Motor immediately begins accelerating, then holds steady at 50 Hz.
Stop	Press STOP key. (Red lamp lights. Red lamp at RUN key goes off). REV lamp stays lit. DRIVE lamp stays lit.		Motor speed decreases under GPD 503 control, at preset deceleration rate, to zero. (See NOTE 1) Motor remains stopped. Lamps and display remain on as long as power is applied.

NOTES:

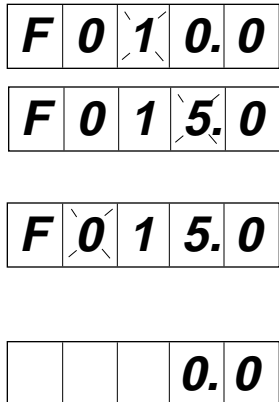
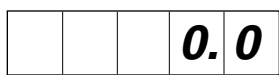
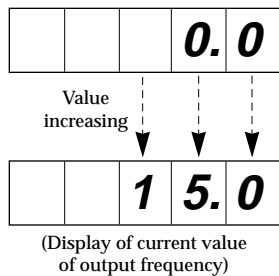
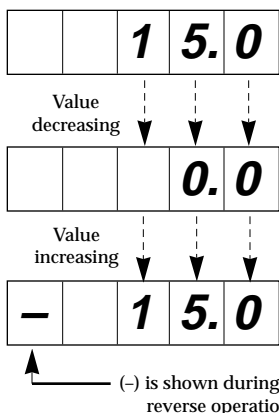
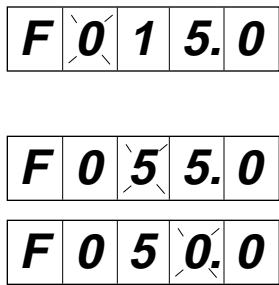
1. For coast-to-stop operation, refer to Appendix 1, Sn-04.

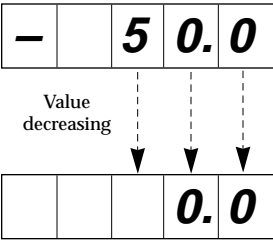
4.3 PRE-OPERATION CONSIDERATIONS

- After completing the start-up, connect the motor to the load.
- Additional control circuit wiring can be added, and constants in the GPD 503 can be programmed to configure the drive system to your specific application, including “Remote” (2-wire or 3-wire) Control. (See Table 2-1 for listing of Programmable Features descriptions.)

4.4 STORAGE FUNCTION

The GPD 503 uses internal NV-RAM to store information when power is removed or in the event of a power failure. Therefore, when power is reapplied, operation will begin at the same state as when power was removed.

The following information is stored:

1. Last monitor display selection (in Drive mode).
2. Last frequency command setting and forward/reverse selection from Digital Operator.
3. The sequence of failure conditions that occurred before power was removed (including content of CPF failure).

Section 5. OPERATION AT LOAD

After completing the start-up, and programming of constants, turn off the AC main circuit power. Make additional wiring connections required for the external control functions selected by the constant programming. Connect the driven machine to the motor. Verify that the driven machine is in running condition, and that no dangerous conditions exist around the drive system.

OPERATING PRECAUTIONS

- Before applying a RUN command to the GPD 503, verify that the motor is stopped. If the application requires the capability of restarting a coasting motor, constant Cn-13 must be set to give DC Braking Time at Start.
- The motor cooling effect lowers during low-speed running. The torque needs to be reduced in accordance with the frequency. For the reduction ratio, refer to the motor catalog or technical sheet.
- **NEVER** use a motor whose "FLA" current exceeds the GPD 503 rating.
- When two or more motors are operated by one GPD 503, verify that the total motor current **DOES NOT EXCEED** the GPD 503 rating.
- When starting and stopping the motor, use the operation signals (RUN/STOP, FWD/REV), NOT the magnetic contactor on the power supply side.

Run the motor under load with control by the Digital Operator using the same procedure as for the Test Run (Table 4-1). If Digital Operator is used in combination with external commands or external commands only are used, the procedure must be altered accordingly.

For preset starting (one-touch operation after setting the frequency), perform the following:

1. Set the frequency and press **RUN**. Motor accelerates, at the rate corresponding to the preset accel time, to the preset frequency. The accel time is set too short relative to the load if the RPM of the accelerating motor does not increase smoothly (stall prevention during acceleration is functioning) or if a fault indication is displayed on the Digital Operator.
2. Press **STOP**. Motor decelerates, at the rate corresponding to the preset decel time, to a stop. The decel time is set too short relative to the load if the RPM of the decelerating motor does not decrease smoothly (stall prevention during deceleration is functioning) or if a fault indication is displayed on the Digital Operator.

Section 6. FAILURE INDICATION AND DETAILS

6.1 GENERAL

A failure in the GPD 503 can fall into one of two categories.

A blinking "Alarm" indication is a warning that a GPD 503 trouble condition will soon occur, or that a problem exists in the external circuitry. The GPD 503 will continue to operate during an "Alarm" indication. "Alarm" indications are not entered into the fault register.

A steady "Fault" indication is displayed when the GPD 503's Fault relay has tripped (GPD 503 shutdown). The motor coasts to a stop, and a fault signal output is present at control circuit terminals 18 - 20.

Table 6-1. Failure Indication and Details

INDICATION (DISPLAY)	FAULT	DESCRIPTION
bb (blinking)	External Base Block command	Base Block command at multi-function terminal is active, shutting off GPD 503 output (motor coasting). Temporary condition, cleared when input command is removed.
bUS	Transmission error	Control data cannot be received normally for longer than 2 seconds.
CALL	Communication ready	Drive is waiting for the PLC to establish communication.
CPF00	Transmission error or control function hardware fault (including internal RAM, external RAM or PROM)	Transmission between GPD 503 and remote operator is not established within 5 seconds after the power supply is turned on. (Displayed on the remote operator.)
CPF01	Transmission error	Transmission error occurs 2 seconds or more after transmission has first been established.
CPF02	Base block circuit failure	GPD 503 failure.
CPF03	NV-RAM (S-RAM) fault	GPD 503 failure.
CPF04	NV-RAM (BCC, Access Code) fault	GPD 503 failure. This fault may be caused after changing EPROM chips. Perform a Sn-03 Reset operation to attempt to clear this fault.
CPF05	A/D converter failure in CPU	GPD 503 failure.
CPF06	Optional connection failure	Improper installation or wiring of option card.
CPF20	A/D converter failure	Defective option card.
CPF21	Transmission interface card (option) self-analysis function fault	Defective option card. Check option card connector for proper installation.
CPF22	Model code fault	Defective option card. Check option card connector for proper installation.
CPF23	Mutual-analysis function fault	Defective option card. Check option card connector for proper installation.

Table 6-1. Failure Indication and Details - Continued

INDICATION (DISPLAY)	FAULT	DESCRIPTION
EF (blinking)	Simultaneous forward and reverse operation commands	Fwd Run and Rev Run commands are both closed for more than 500 ms. Removing one command will allow drive operation.
EF0	External fault	GPD 503 is in Stop mode.
EF3	Ext. fault signal at term. 3	A fault condition has occurred in the external circuit(s) monitored by the contact providing input to the indicated terminal. If display is steady, GPD 503 is in Stop mode; if display is blinking, the terminal is programmed to allow continued operation after receiving fault input.
EF5	Ext. fault signal at term. 5	
EF6	Ext. fault signal at term. 6	
EF7	Ext. fault signal at term. 7	
EF8	Ext. fault signal at term. 8	
Err	Constant write-in fault	Temporary display, in Program mode, indicating that constant setting was not written into EPROM memory.
FAn	Cooling fan failure	GPD 503 is in Stop mode.
FU	Fuse blown	DC Bus fuse has cleared. Check for short circuit in output, and check main circuit transistors.
GF	Ground fault protection	Ground current > approx. 50% of the GPD 503 rated current.
oC	Overcurrent	GPD 503 output current exceeds 200% of GPD 503 rated current, or ground fault has occurred, with ground current exceeding 50% of GPD 503 rated current.
oH	Heat sink overheated	Fin temperature exceeds 90° C (194° F)
oH2 (blinking)	External overheat	External temperature monitoring circuit(s) detected an overtemperature condition and produced an input signal.
oL1	Overload	Thermal motor overload protection has tripped.
oL2	Overload	GPD 503 overload protection has tripped.
oL3 (blinking)	Overload	GPD 503 output torque exceeds the set Overtorque Detection level, but GPD 503 is programmed for continued operation at overtorque detection.
oL3	Overload	GPD 503 output torque exceeds the set Overtorque Detection level, and GPD 503 is programmed for coast to stop at overtorque detection.
oPE01 *	kVA constant setting fault	Sn-01 setting is incorrect.
oPE02 *	Constant setting range fault	An-XX, bn-XX, Cn-XX, or Sn-XX setting range fault.
oPE03 *	Constant set value fault	Sn-15 to -18 (multi-function input) set value fault.
oPE04 *	Constant set value fault	PG constant, number of poles, or PG division rate set incorrectly.
oPE10 *	Constant set value fault	Cn-02 to -08 (V/f data) set incorrectly.
oPE11 *	Constant set value fault	One of the following conditions was detected: <ul style="list-style-type: none"> • Cn-23 > 5 KHz and Cn-24 ≤ 5 KHz • Cn-25 > 6 and Cn-24 > Cn-23

* These fault displays occur only when in the Program mode, when changing back to Drive mode from Program mode, or when applying power to the GPD 503.

Table 6-1. Failure Indication and Details - Continued

INDICATION (DISPLAY)	FAULT	DESCRIPTION
ou (blinking)	Overvoltage	Internal monitor of DC Bus voltage indicates that input AC power is excessively high, while GPD 503 is in stopped condition.
ou	Overvoltage (OV)	Detection level: Approx. 400V for 230V GPD 503; Approx. 800V for 460V GPD 503 (700V if Cn-01 < 400); Approx. 1000V for 575V GPD 503. Reset level: 385V.
rr	Regenerative transistor failure	Dynamic Braking resistor has failed.
rH	Braking resistor unit overheated	Dynamic Braking resistor has overheated.
Uu (blinking)	Low voltage (Power UV)	Internal monitor of DC Bus voltage indicates that input AC power is below Undervoltage detection level, while the GPD 503 is in stopped condition.
Uu1	Low voltage (Power UV)	Occurs two seconds after detection of low voltage. (See "Undervoltage" specification, under "Protective Functions", in Appendix 2.)
Uu2	Low voltage (Control UV)	Control circuit voltage levels drop below acceptable levels during operation.
Uu3	Low voltage (MC-ANS fault)	Main circuit magnetic contactor does not operate correctly.

6.2 DISPLAYING FAULT SEQUENCE

Whenever the Fault relay trips and shuts down the GPD 503, the display code of the fault that caused the trip (except for Illegal Constant [**OPE** _ _] or Control Function Error { **CPF** _ _ }) is entered into a register in NV-RAM memory. This register retains, in sequence, that fault code and those of up to three immediately preceding the shutdown failure.

A newly occurring fault code will not change the fault register if it is a recurrence of the most recently entered fault (i.e. no. 1 position in the memory register).

The contents of this register can be displayed when the GPD 503 is in the Drive mode.

A. After GPD 503 Fault Shutdown (With Power Still Applied).

Table 6-2. Displaying Fault Sequence After Fault Shutdown

STEP	OPERATION PROCEDURE	DIGITAL DISPLAY															
1	Before a RESET command is entered, the fault that caused Fault trip (shutdown) is displayed.	<table border="1" style="display: inline-table; vertical-align: middle;"> <tr> <td style="width: 20px; height: 20px;"></td> <td style="width: 20px; height: 20px;"></td> <td style="width: 20px; height: 20px;"></td> <td style="width: 20px; height: 20px; text-align: center;">0</td> <td style="width: 20px; height: 20px; text-align: center;">C</td> </tr> </table>				0	C										
			0	C													
2	Press \wedge . The display indicates that this is currently the first code in the memory register.	<table border="1" style="display: inline-table; vertical-align: middle;"> <tr> <td style="width: 20px; height: 20px;"></td> <td style="width: 20px; height: 20px; text-align: center;">1</td> <td style="width: 20px; height: 20px;"></td> <td style="width: 20px; height: 20px; text-align: center;">0</td> <td style="width: 20px; height: 20px; text-align: center;">C</td> </tr> </table>		1		0	C										
	1		0	C													
3	Continue pressing \wedge to display the other codes in the memory register. After the last register code is displayed, the sequence will return to the first code.	<table border="1" style="display: inline-table; vertical-align: middle; margin-bottom: 5px;"> <tr> <td style="width: 20px; height: 20px;"></td> <td style="width: 20px; height: 20px; text-align: center;">2</td> <td style="width: 20px; height: 20px;"></td> <td style="width: 20px; height: 20px; text-align: center;">0</td> <td style="width: 20px; height: 20px; text-align: center;">U</td> </tr> </table> <table border="1" style="display: inline-table; vertical-align: middle; margin-bottom: 5px;"> <tr> <td style="width: 20px; height: 20px;"></td> <td style="width: 20px; height: 20px; text-align: center;">3</td> <td style="width: 20px; height: 20px;"></td> <td style="width: 20px; height: 20px; text-align: center;">0</td> <td style="width: 20px; height: 20px; text-align: center;">H</td> </tr> </table> <table border="1" style="display: inline-table; vertical-align: middle;"> <tr> <td style="width: 20px; height: 20px;"></td> <td style="width: 20px; height: 20px; text-align: center;">1</td> <td style="width: 20px; height: 20px;"></td> <td style="width: 20px; height: 20px; text-align: center;">0</td> <td style="width: 20px; height: 20px; text-align: center;">C</td> </tr> </table>		2		0	U		3		0	H		1		0	C
	2		0	U													
	3		0	H													
	1		0	C													

After the fault sequence has been examined, troubleshoot the most recent fault or enter a Fault Reset command (by Digital Operator **RESET** key or external signal at term. 4) to prepare the GPD 503 for restart of operation.





6.2 DISPLAYING FAULT SEQUENCE

Continued

B. At Power-Up.

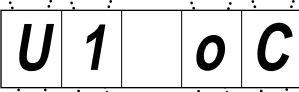
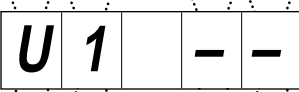
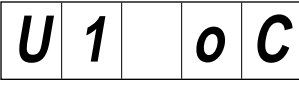
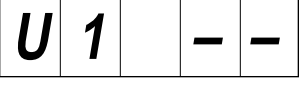
In Table 6-3, digital display A occurs if there was a Fault trip (shutdown) before turning off power. Digital display B occurs if there was no shutdown.

Table 6-3. Displaying Fault Sequence After Power-up

STEP	OPERATION PROCEDURE	DIGITAL DISPLAY	
		A	B
1	Turn on power.	 <p>Blinking for 5 seconds, then last selected monitor display.</p>	 <p>Blinking for 5 seconds, then last selected monitor display.</p>
2	Press ^ while holding DSPL/ENTR to select Previous Fault Display.		
3	Continue pressing ^ to display the other codes in the memory register. After the last code is displayed, the sequence will return to the first code.	 	 

After the fault sequence has been examined, refer to paragraph 3.4 B.

Section 7. TROUBLESHOOTING

If the GPD 503 malfunctions, locate the cause and take corrective action by following the flowcharts given in this section.

A. TROUBLESHOOTING MOTOR SYMPTOMS

Motor Will Not Run.....	Chart 7.1
Motor Stalls During Acceleration	Chart 7.2

B. TROUBLESHOOTING FOR FAULT CONDITIONS

Overvoltage (ou).....	Chart 7.3
Blown Fuse (FU).....	Chart 7.4
Overcurrent (oC).....	Chart 7.5
Overload (oL).....	Chart 7.6
Undervoltage (Uu).....	Chart 7.7
GPD 503 Overheated (oH).....	Chart 7.8
Control Function Error (CPF_ _).....	Chart 7.9
Fault Signal Input (EF_).....	Chart 7.10

WARNING

Oscilloscope chassis may be at voltages potentially hazardous to life if not properly grounded. If oscilloscope is used to measure high voltage waveforms, use only a dual channel oscilloscope in the differential mode with X100 probes. Always connect oscilloscope chassis to earth ground.

WARNING

Voltages dangerous to life exist when equipment is open and energized. Do not work alone.

CAUTION

To prevent equipment damage always remove incoming three-phase power before test equipment is connected or removed.

CAUTION

If the GPD 503 Control PCB is replaced, ALL GPD 503 CONSTANTS MUST BE REPROGRAMMED for your application.

TROUBLESHOOTING CHART 7.1

MOTOR WILL NOT RUN

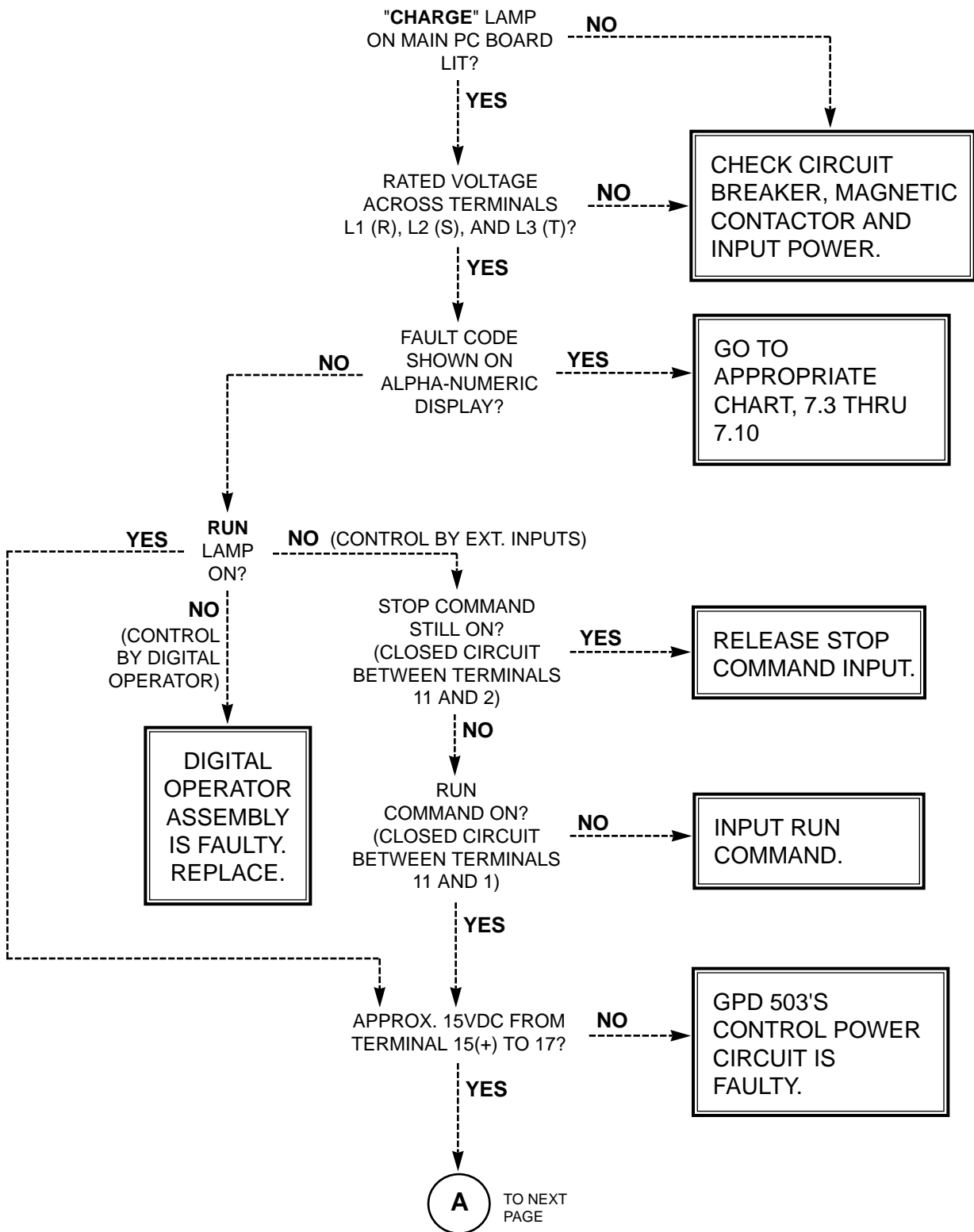

TROUBLESHOOTING CHART 7.1 (Continued)

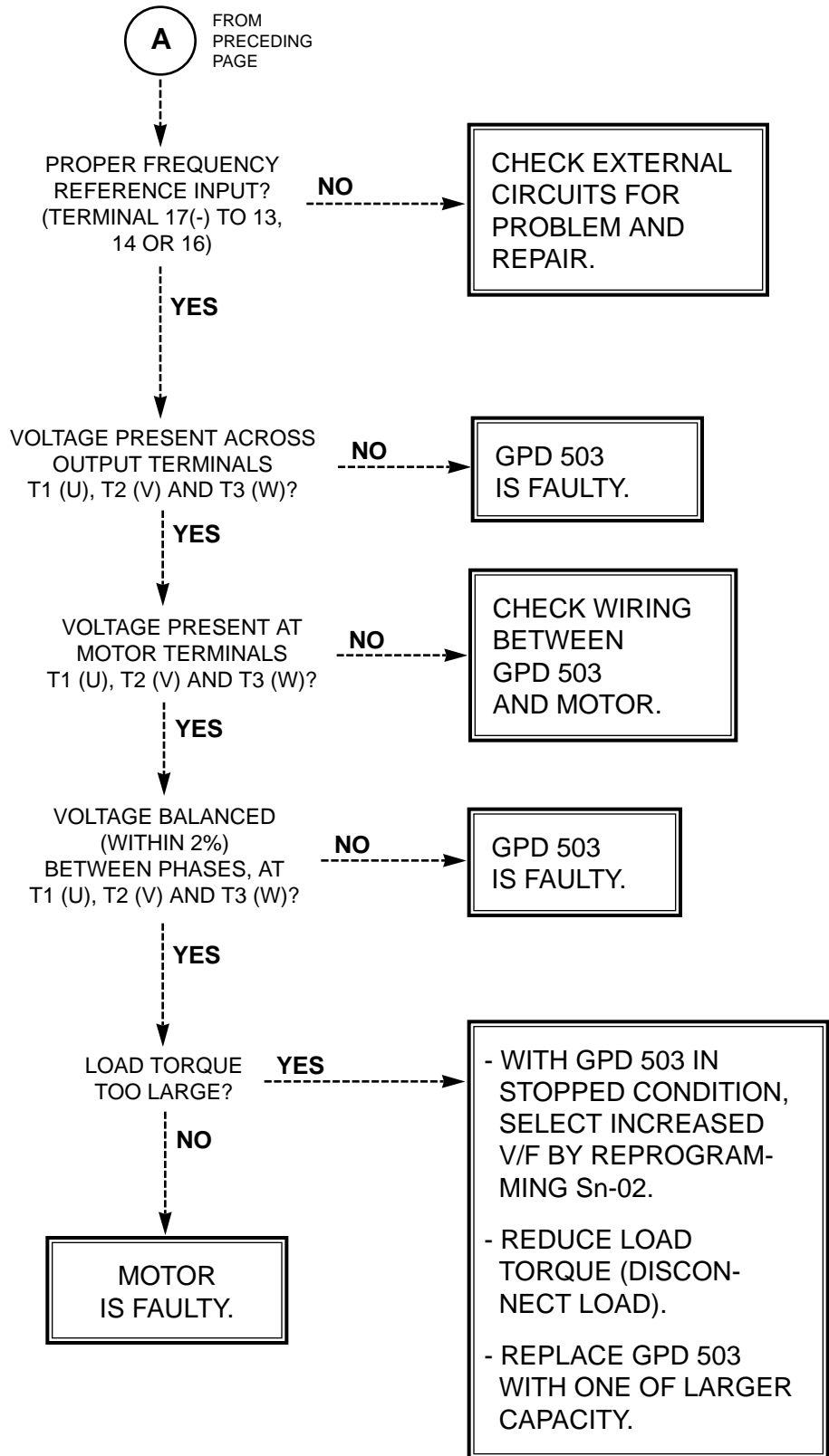

TROUBLESHOOTING CHART 7.2

MOTOR STALLS DURING ACCELERATION

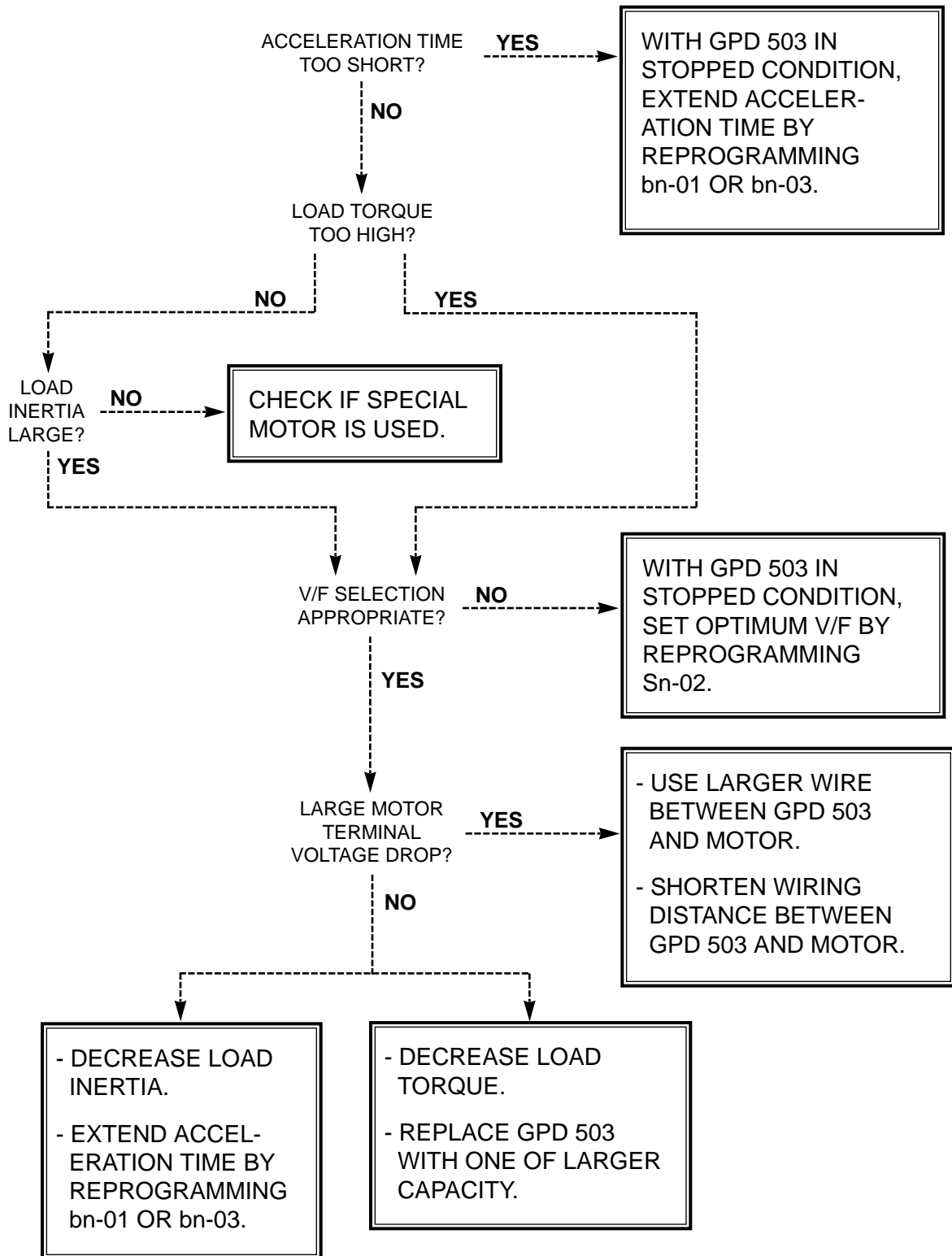

TROUBLESHOOTING CHART 7.3

OVERVOLTAGE (*ou*) FAULT INDICATION

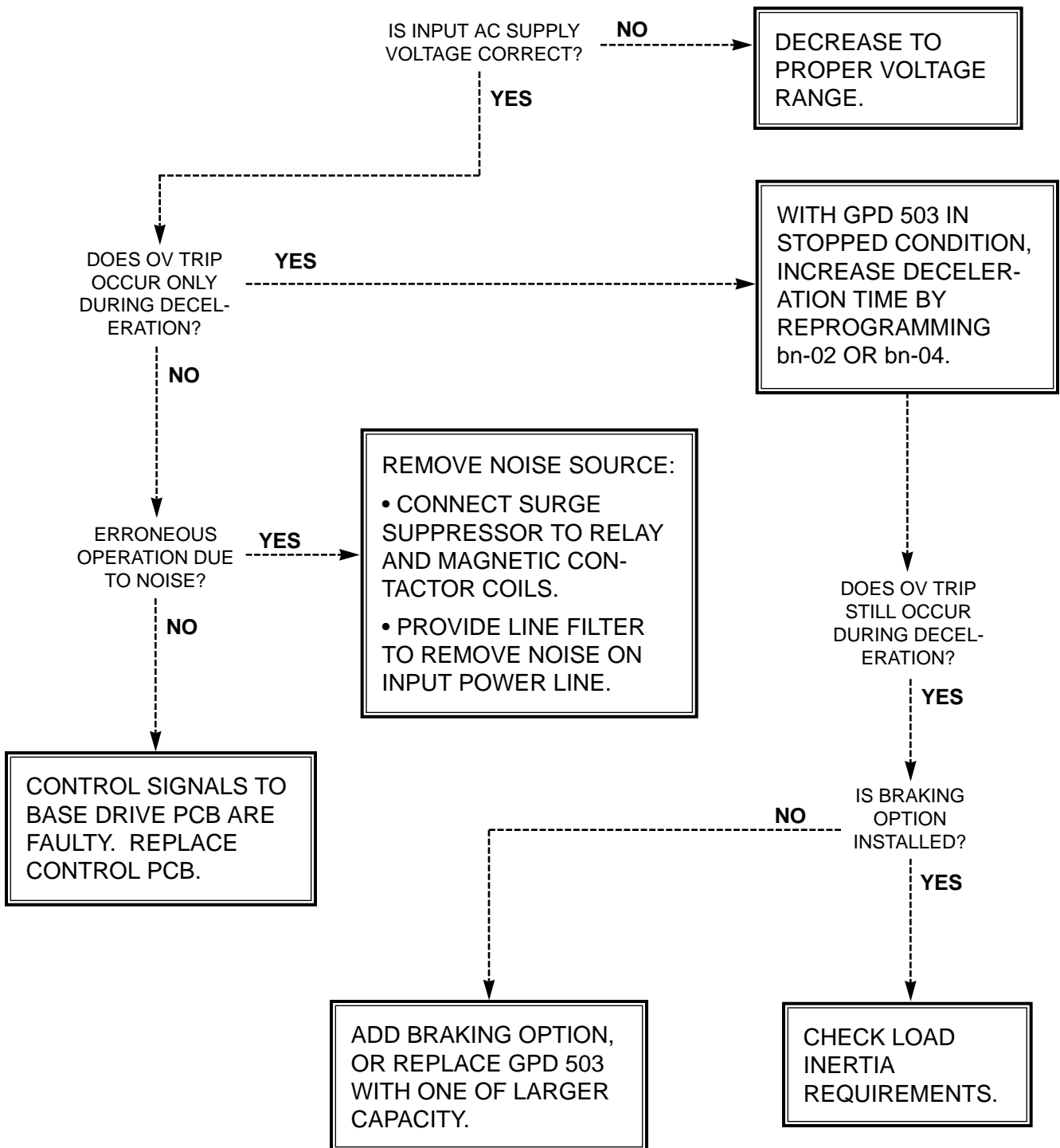

TROUBLESHOOTING CHART 7.4

BLOWN FUSE (FU) FAULT INDICATION

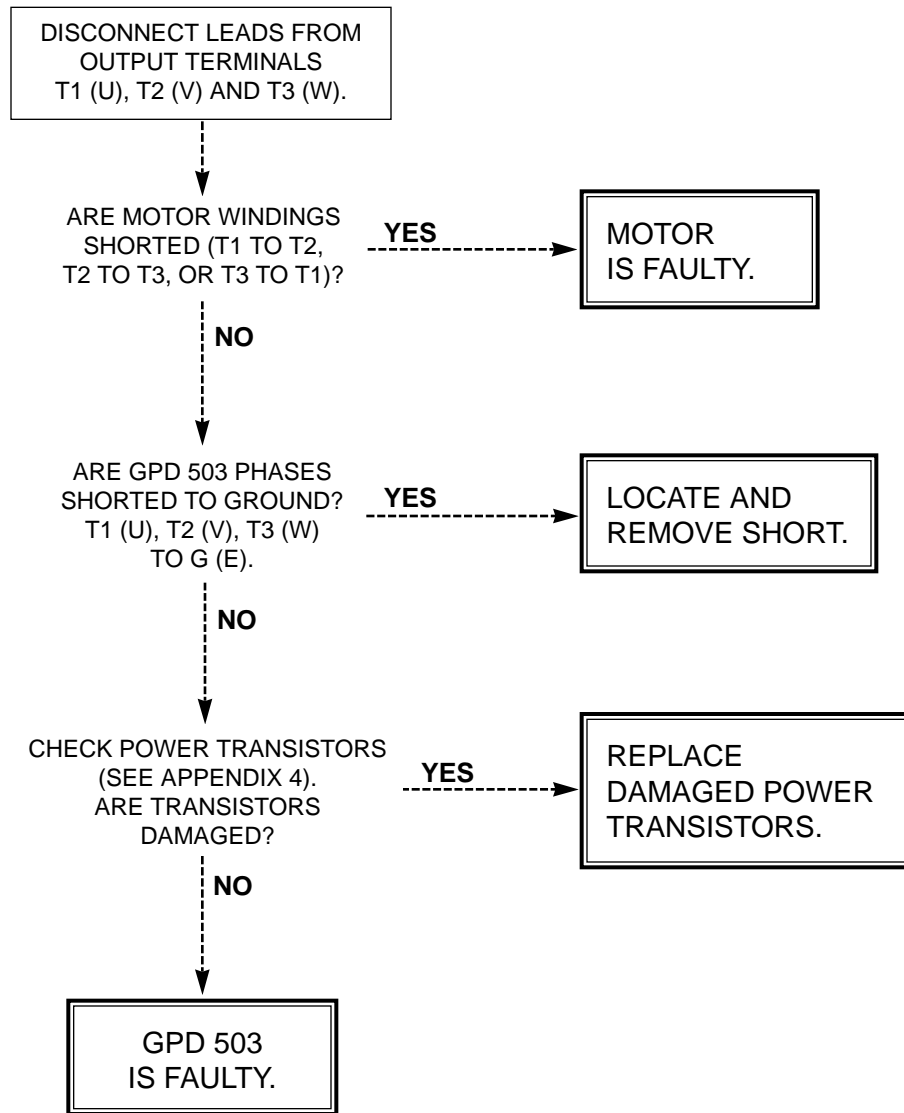

CAUTION

Do not replace DC Bus fuse without first checking output transistors.

TROUBLESHOOTING CHART 7.5

OVERCURRENT (oC) FAULT INDICATION

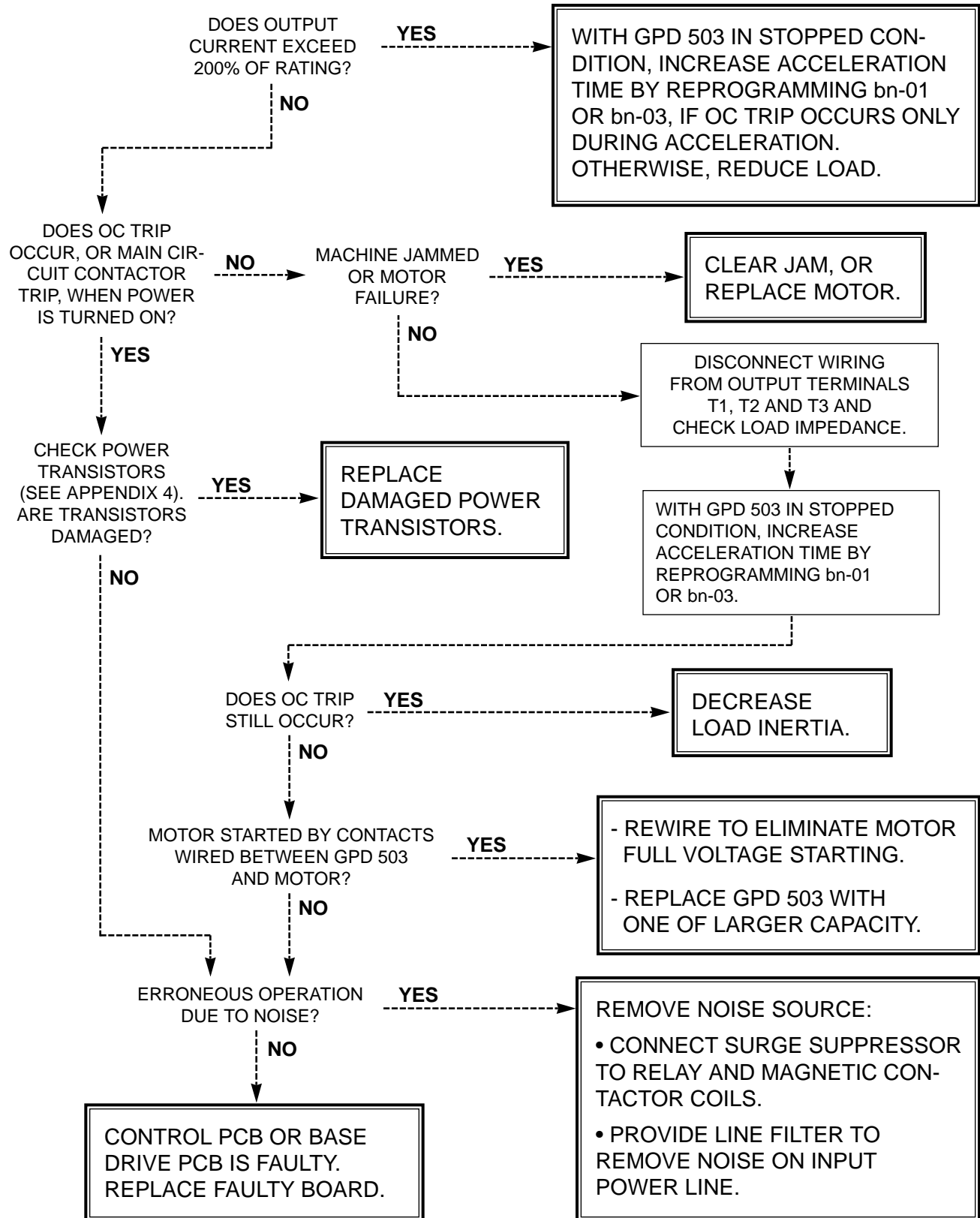

TROUBLESHOOTING CHART 7.6

OVERLOAD (oL) FAULT INDICATION

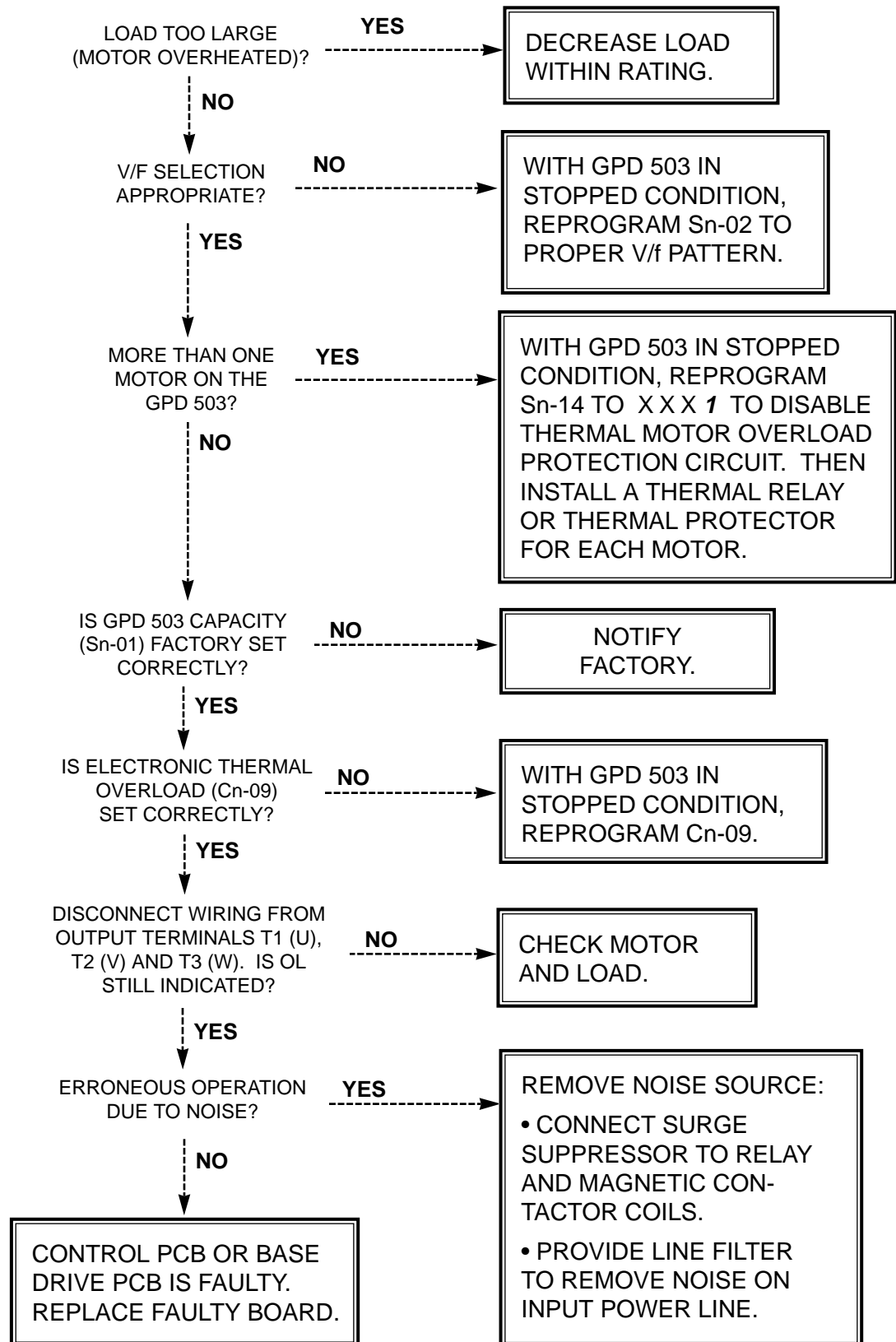

TROUBLESHOOTING CHART 7.7

UNDERVOLTAGE (U_u) FAULT INDICATION

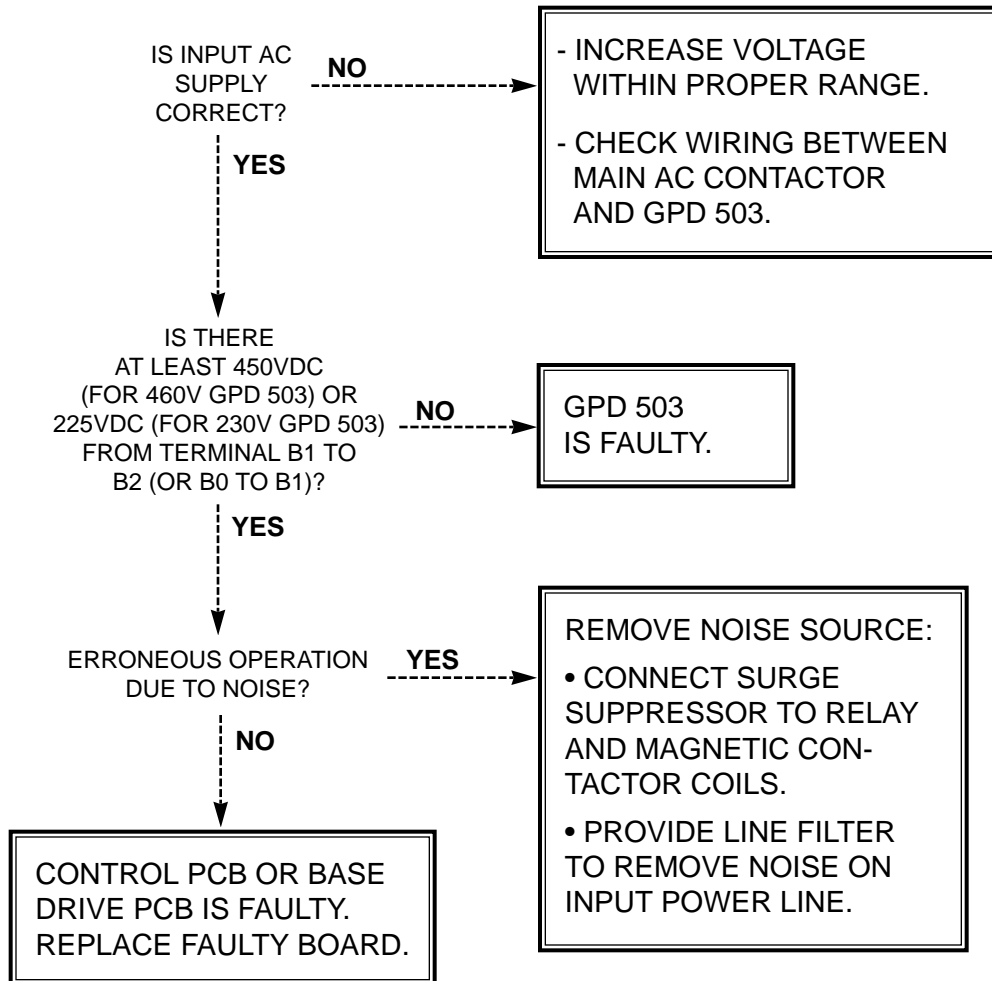

TROUBLESHOOTING CHART 7.8

INVERTER OVERHEATED (oH) FAULT INDICATION

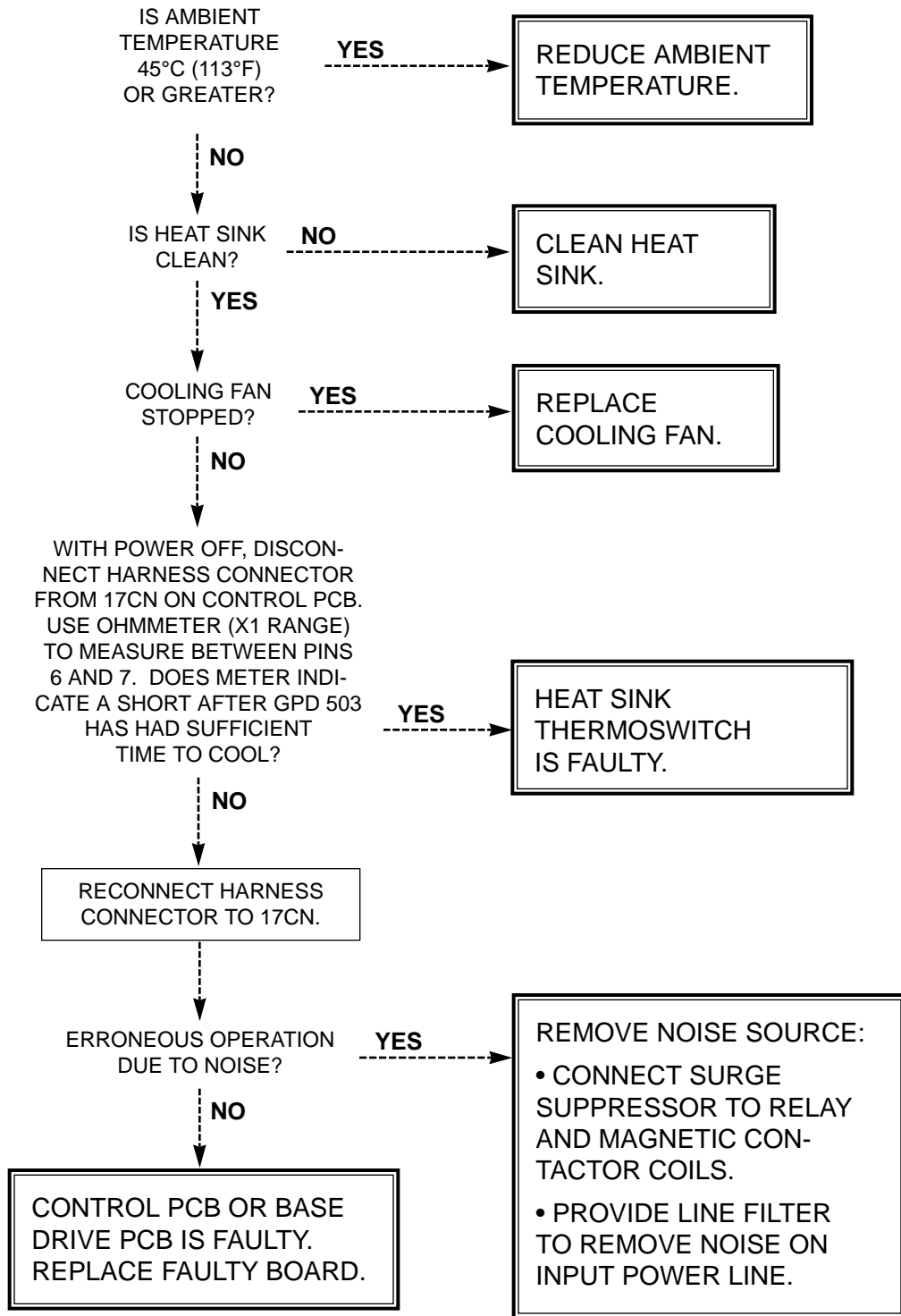

TROUBLESHOOTING CHART 7.9

CONTROL FUNCTION ERROR (*CPF*__) FAULT INDICATION

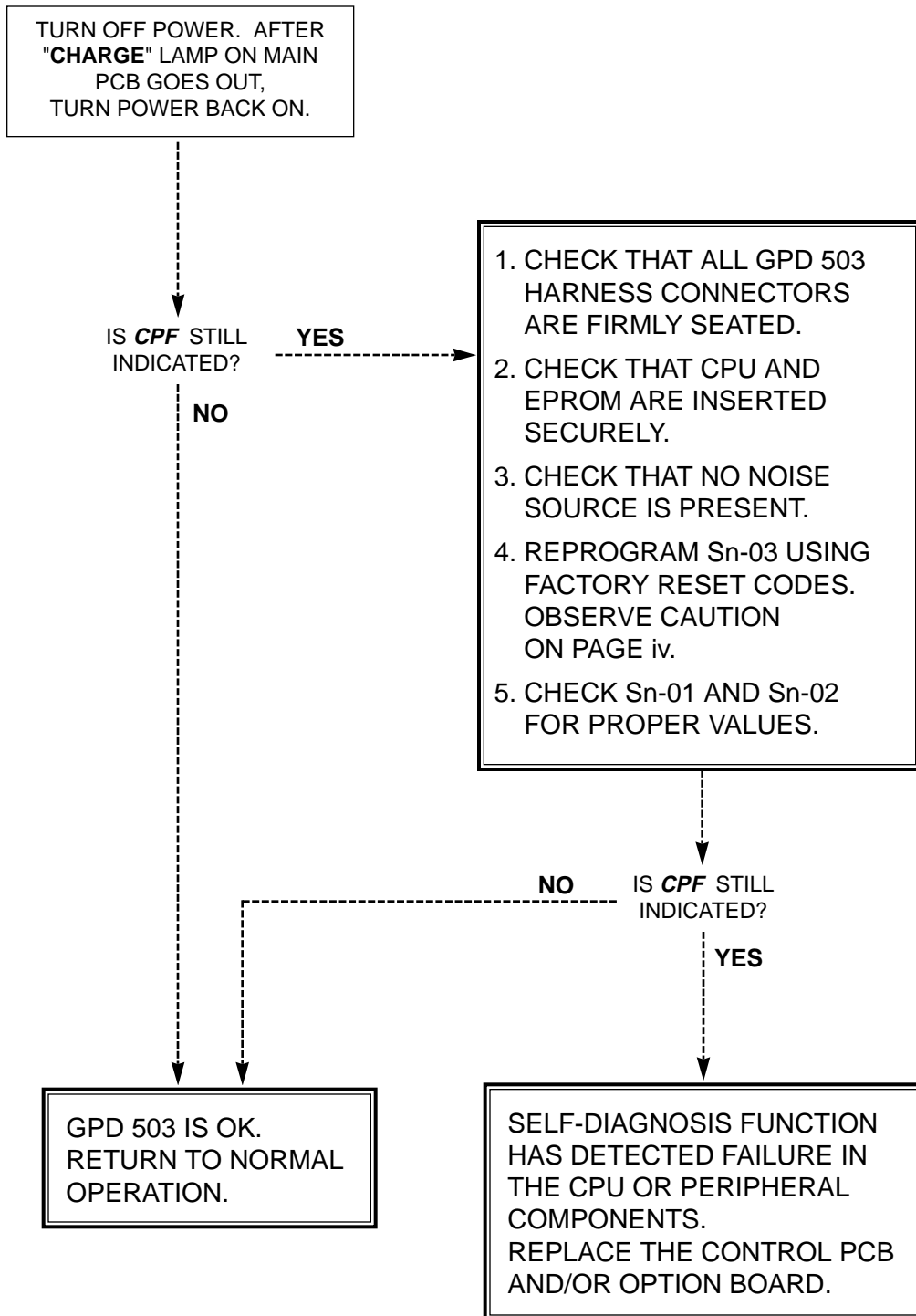

TROUBLESHOOTING CHART 7.10

EXTERNAL FAULT (EF_) INDICATION

*

IS AN EXTERNAL FAULT SIGNAL
PRESENT (OPEN OR CLOSED **
CIRCUIT BETWEEN
TERMINAL 3 AND 11;
OR OPEN OR CLOSED **
CIRCUIT BETWEEN TERMINAL
11 AND WHICHEVER TERMINAL
(5-8) HAS BEEN PROGRAMMED
FOR EXT. FAULT INPUT)?

YES

**FAULT HAS OCCURRED
IN CIRCUITS OUTSIDE
THE GPD 503.
TROUBLESHOOT AND
CORRECT.**

NO

**CONTROL PCB IS
FAULTY. REPLACE.**

* THIRD DIGIT OF FAULT DISPLAY
INDICATES WHICH TERMINAL IS
INVOLVED.

** DEPENDING ON WHETHER THE
TERMINAL HAS BEEN PROGRAMMED
TO MONITOR A N.O. OR N.C.
CONTACT.

Appendix 1. LISTING OF CONSTANTS

The GPD 503 control circuits use five types of constants to select functions and characteristics of the GPD 503. Changing of constant settings must be done in the Program mode, unless otherwise indicated.

1. Frequency Reference Memory Settings (An-XX) (settings can be changed at any time)
2. Run Operative settings (bn-XX) (settings can be changed at any time)
3. System constants (Sn-XX)
4. Control constants (Cn-XX)
5. Monitor Display (Un-XX) (monitor selection only; not programmable by user)

The following tables list all constants of each type in numerical order. For each constant, reference paragraph(s) in Section 2 are listed (if applicable) where the features of the GPD 503 affected by that constant are described.

Table A1-1. Frequency Reference Memory Settings (An-XX)

CONSTANT NUMBER	DATA NAME	INCREMENT	SETTING RANGE	FACTORY SETTING	USER SETTING	PARA. REF.
An-01	Frequency Reference 1	0.01 Hz	0.00 - 400.00	0.00		2.24
An-02	Frequency Reference 2	0.01 Hz	0.00 - 400.00	0.00		2.24
An-03	Frequency Reference 3	0.01 Hz	0.00 - 400.00	0.00		2.24
An-04	Frequency Reference 4	0.01 Hz	0.00 - 400.00	0.00		2.24
An-05	Frequency Reference 5	0.01 Hz	0.00 - 400.00	0.00		2.24
An-06	Frequency Reference 6	0.01 Hz	0.00 - 400.00	0.00		2.24
An-07	Frequency Reference 7	0.01 Hz	0.00 - 400.00	0.00		2.24
An-08	Frequency Reference 8	0.01 Hz	0.00 - 400.00	0.00		2.24
An-09	Jog Reference	0.01 Hz	0.00 - 400.00	6.00		2.15, 2.24

Table A1-2. Run Operative Settings (bn-XX)

CONSTANT NUMBER	DATA NAME	INCREMENT	SETTING RANGE	FACTORY SETTING	USER SETTING	PARA. REF.
bn-01	Accel Time 1	0.1 s	0.0 - 6000.0	10.0		2.2A, 2.2C, 2.18
bn-02	Decel Time 1	0.1 s	0.0 - 6000.0	10.0		2.2A, 2.2C, 2.18
bn-03	Accel Time 2	0.1 s	0.0 - 6000.0	10.0		2.2A, 2.2C, 2.18
bn-04	Decel Time 2 (also Emergency Stop Decel Time)	0.1 s	0.0 - 6000.0	10.0		2.2A, 2.2C, 2.18
bn-05	Frequency Command Gain	0.1 %	0 - 1000.0	100.0		2.13
bn-06	Frequency Command Bias	1 %	-100 to 100	0		2.13
bn-07	Torque Compensation Gain	0.1	0.0 - 2.0	1.0		2.31
bn-08	Slip Compensation Gain (Motor Rated Slip)	0.1 %	0.0 - 9.9	0.0		2.26, 2.35
bn-09	Energy Saving Gain	1 %	0 - 200	80		2.11
bn-10	Monitor No. After Power-up	1	1 - 3	1		2.10
bn-11	Analog Monitor Channel 1 Gain	0.01	0.01 - 2.55	1.00		2.20 (1)
bn-12	Analog Monitor Channel 2 Gain	0.01	0.01 - 2.55	0.50		(1)

(1) Refer to separate Option Instruction Sheet.

Table A1-3. System Constants (Sn-XX)

CONSTANT NUMBER	DATA NAME	DIGIT	SET DATA	FUNCTION	FACTORY SETTING	USER SETTING	PARA. REF.
Sn-01	kVA (HP) Select	--	GPD 503 capacity selection		See App. 3, Table A3-1	--	--
Sn-02	V/f Select	--	V/f pattern selection		01		2.32, 2.33
Sn-03	Operator Status	<u>XXXX</u>	0000 = Setting and reading of An-, bn-, Sn-, and Cn- constants 1110 = NV-RAM initialization (reset) for 2-wire control operation 1111 = NV-RAM initialization (reset) for 3-wire control operation		0000		2.25
Sn-04	Operation Mode Select 1	<u>XXXX</u>	0	Auto reference at external terminals 13 & 17 or 14 & 17	0011		2.24, 2.24.1
			1	Frequency reference by memory setting in An-01			
		<u>XXXX</u>	0	Run/Stop by external input signals			
			1	Run/Stop by means of Digital Operator keypad			
		<u>XXXX</u>	00 = Ramp to stop 01 = Coast to stop 10 = Full-range DC injection braking stop 11 = Coast to stop (setting of bn-02 provides time delay before accepting run command)	2.8A			
Sn-05	Operation Mode Select 2	<u>XXXX</u>	0	Stop command from either Digital Operator or external terminal	0000		--
			1	Stop command from external terminal only			
		<u>XXXX</u>	0	Reverse Run enabled			
			1	Reverse Run disabled			
		<u>XXXX</u>	0	Double-reading function of sequence reference			
			1	Single-reading function of sequence reference			
		<u>XXXX</u>	0	Multi-function analog output (term. 21 & 22) [also depends on Sn-09 XXXX setting]			2.20
			1	Multi-function analog output (term. 21 & 22) [also depends on Sn-09 XXXX setting]			

Table A1-3. System Constants (Sn-XX) - Continued

CONSTANT NUMBER	DATA NAME	DIGIT	SET DATA	FUNCTION	FACTORY SETTING	USER SETTING	PARA. REF.
Sn-06	Operation Mode Select 3	XXXX —	00	S-curve at Accel/Decel, with 0.2 second delay	0000		2.27
			01	S-curve at Accel/Decel disabled			
			10	S-curve at Accel/Decel, with 0.5 second delay			
			11	S-curve at Accel/Decel, with 1.0 second delay			
		XXXX —	0	Output frequency proportional to Auto reference			2.3
			1	Output frequency inversely proportional to Auto ref.			
		XXXX —	0	Auto Reference - Loss Detection disabled			2.4
1	Auto Reference - Loss Detection enabled						
Sn-07	Overtorque Detection	XXXX —	0	Overtorque detection is disabled	0000		2.22
			1	Overtorque detection is enabled			
		XXXX —	0	Detects only during set frequency			
			1	Detects during all frequency conditions			
		XXXX —	0	Operation continues after overtorque detection			
			1	Coasts to stop when overtorque is detected			
		XXXX —	-	Not Used			
Sn-08	Option Reference Select	XXXX —	0	Operated from installed option	0100		See Option Instructions
			1	Operated from Digital Operator and/or external terminals			
		XXXX —	0	Run/Stop from installed option card			
			1	Run/Stop from Digital Operator and/or external terminals			

Table A1-3. System Constants (Sn-XX) - Continued

CONSTANT NUMBER	DATA NAME	DIGIT	SET DATA	FUNCTION	FACTORY SETTING	USER SETTING	PARA. REF.
Sn-08	(Continued)	XXXX —		Condition when Communication Interface Card communication error occurs: 00 = Ramp to stop (decel time = bn-02 setting) 01 = Coast to stop 10 = Ramp to stop (decel time = bn-04 setting) 11 = Operation continues			
Sn-09	Analog Monitor Selection Method	XXXX —	0	Analog output (terminals 21-22) is set by Sn-05 <u>XXXX</u> and Sn-09 <u>XXXX</u>	0000		--
			1	Analog output (terminals 21-22) is set by communication interface card (SI-B)			
	Analog Monitor Selection	XXXX —	0	Multi-function analog output (term. 21-22) [also depends on Sn-05 <u>XXXX</u> setting]			2.20
			1	Multi-function analog output (term. 21-22) [also depends on Sn-05 <u>XXXX</u> setting]			
		XXXX —	-	Not Used			
Sn-10	Protective-Characteristics Select 1 (Stall Prevention)	XXXX —	0	Stall prevention during accel enabled	0000		2.29
			1	Stall prevention during accel disabled			
		XXXX —	0	Stall prevention during decel enabled			
			1	Stall prevention during decel disabled			
		XXXX —	0	Stall prevention during operation enabled			
			1	Stall prevention during operation disabled			
		XXXX —	0	Decel time during stall prevention is "DECEL TIME 1" (bn-02 set value)			
			1	Decel time during stall prevention is "DECEL TIME 2" (bn-04 set value)			

Table A1-3. System Constants (Sn-XX) - Continued

CONSTANT NUMBER	DATA NAME	DIGIT	SET DATA	FUNCTION	FACTORY SETTING	USER SETTING	PARA. REF.	
Sn-11	Protective Characteristics Select 2 (Momentary Power Loss Protection)	XXXX —	0	Braking resistor (heat sink mounted) not provided. Overheat protection disabled.	0000		Separate Option Instruction Sheet	
			1	Braking resistor (heat sink mounted) provided. Overheat protection enabled.				
		XXXX —	0	Fault contact status during auto restart: remains open				2.5B
			1	Fault contact status during auto restart: closes				
		XXXX —	0	Operation stops when momentary power loss is detected				2.16, 2.5A
			1	Operation continues during momentary power loss				
		XXXX —	—	Not used				--
Sn-12	Protective Characteristics Select 3 (External Fault Signal Input at Terminal 3)	XXXX —	0	External fault signal: N.O. contact input	0100		2.12A	
			1	External fault signal: N.C. contact input				
		XXXX —	0	External fault signal always detected				
			1	External fault signal only detected during operation				
		XXXX —	Condition when external fault signal is detected: 00 = Ramp to stop (major failure) 01 = Coast to stop (major failure) 10 = Emergency stop (major failure) Time to stop determined by bn-04 set value 11 = Continue operation (minor failure)					

Table A1-3. System Constants (Sn-XX) - Continued

CONSTANT NUMBER	DATA NAME	DIGIT	SET DATA	FUNCTION	FACTORY SETTING	USER SETTING	PARA. REF.
Sn-13	Protective Characteristics Select 4 (Overload / Fan Fault Protection)	XXXX —	—	Not Used	0100		--
		XXXX —		Condition when cooling fan failure is detected: 00 = Ramp to stop (major failure) 01 = Coast to stop (major failure) 10 = Emergency stop (major failure) Time to stop determined by bn-12 set value 11 = Continue operation (minor failure)			--
Sn-14	Protective Characteristics Select 5 (Motor Protection)	XXXX —	0	Electronic thermal motor protection enabled	0000		2.30
			1	Electronic thermal motor protection disabled			
		XXXX —	0	Electronic thermal protection for variable torque			
			1	Electronic thermal protection for constant torque			
		XXXX —	0	Short time rating disabled			
	1		Electronic thermal protection - short time rating enabled				
(Drive Protection)	XXXX — ♦	0	OL = 103% continuous, 150% for one minute				
		1	OL = 113% continuous, 125% for one minute				

♦ This digit is "Not Used" in 230V, 30HP (CT) and below; 460V, 60HP (CT) and below; 575V, 25HP (CT) and below.

Table A1-3. System Constants (Sn-XX) - Continued

CONSTANT NUMBER	DATA NAME	DIGIT	SET DATA	FUNCTION	FACTORY SETTING	USER SETTING	PARA. REF.
Sn-15 ⌘	Terminal 5 Function	--	00 - FF	Selects terminal 5 function (Auto/Man select)	03 (00) *		2.19, 2.2B, 2.8D, 2.11, 2.12B, 2.15, 2.24, 2.28A
Sn-16 ⌘	Terminal 6 Function	--	00 - FF	Selects terminal 6 function (multi-step frequency ref. select)	04 (03) *		2.19, 2.2B, 2.8D, 2.11, 2.12B, 2.15, 2.24, 2.28A
Sn-17 ⌘	Terminal 7 Function	--	00 - FF	Selects terminal 7 function (Jog)	06 (04) *		2.19, 2.2B, 2.8D, 2.11, 2.12B, 2.15, 2.24, 2.28A
Sn-18 ⌘	Terminal 8 Function	--	00 - FF	Selects terminal 8 function (external baseblock by N.O. contact input)	08 (06) *		2.19, 2.2B, 2.8D, 2.11, 2.12B, 2.15, 2.24, 2.28A
Sn-19	Multi-function Analog Input (Term. 16)	--	00 - FF	Selects terminal 16 function	00		2.18, 2.2C, 2.8C, 2.22, 2.24, 2.29
Sn-20	Multi-function Output 1	--	00 - FF	Selects multi-function contact (terminals 9 & 10) function	00		2.21, 2.22, 2.23
Sn-21	Multi-function Output 2	--	00 - FF	Selects multi-function open collector (terminal 25) function	01		2.21, 2.22, 2.23
Sn-22	Multi-function Output 3	--	00 - FF	Selects multi-function open collector (terminal 26) function	02		2.21, 2.22, 2.23
Sn-25	Analog Speed Setter (AI-14B)	XXXX	0	Plus/minus values of frequency reference sum enabled	0000		Separate Option Instruction Sheet
			1	Plus value of frequency reference sum enabled			
		XXXX	-	Not Used			--

* () are constant settings after 3-wire Reset Code has been entered.
 ⌘ Settings of these four constants MUST be in ascending value.

Table A1-3. System Constants (Sn-XX) - Continued

CONSTANT NUMBER	DATA NAME	DIGIT	SET DATA	FUNCTION	FACTORY SETTING	USER SETTING	PARA. REF.
Sn-26	Digital Speed Reference (DI-08) Frequency reference set mode selection	XXXX		0000 = BCD input, 1% accuracy 0001 = BCD input, 0.1% accuracy 0010 = BCD input, 0.01% accuracy 0011 = BCD input, 1Hz 0100 = BCD input, 0.1Hz 0101 = BCD input, 0.01Hz 0110 = Reserve 0111 = Binary input, 255 / 100% 1000 = Binary input (set value displayed in decimal on Digital Operator)	0000		Separate Option Instruction Sheet
Sn-27	Digital Output Card (DO-08)	XXXX	0	DO-08 output signal combination 1 (output data fixed)	0010		Separate Option Instruction Sheet
			1	DO-08 output signal combination 2 (encoded output)			
	Pulse Monitor (PO-36F)	XXXX	Number of output pulses selection	000 = 1F 001 = 6F 010 = 10F 011 = 12F 100 = 36F			Separate Option Instruction Sheet
Sn-28	Analog Monitor (AO-08 or AO-12)	XXXX	Select item to output from channel 1	00 = Output frequency (max. frequency /100%) 01 = Output current (rated current /100%) 10 = Output voltage ref. (input voltage /100%) 11 = DC voltage [Vpn] (400V /100%) [230V drives] (800V /100%) [460V drives] (1000V /100%) [575V drives]	0100		Separate Option Instruction Sheet
		XXXX	Select item to output from channel 2				

Table A1-4. Control Constants (Cn-XX)

CONSTANT NUMBER	DATA NAME	INCREMENT	SETTING RANGE	FACTORY SETTING	USER SETTING	PARA. REF.
Cn-01	Output Voltage Regulator	0.1 V	0.0 - 255.0 (230V) 0.0 - 510.0 (460V) 0.0 - 730.0 (575V)	230.0 (230V) 460.0 (460V) 575.0 (575V)		2.32
Cn-02	Frequency - Max.	0.1 Hz	50.0 - 400.0	60.0 <i>See Note 1</i>		2.32
Cn-03	Voltage - Max.	0.1 V	0.0 - 255.0 (230V) 0.0 - 510.0 (460V) 0.0 - 730.0 (575V)	230.0 (230V) 460.0 (460V) 575.0 (575V) <i>See Note 1</i>		2.31
Cn-04	Frequency - Max. Voltage Point	0.1 Hz	0.0 - 400.0	60.0 <i>See Note 1</i>		2.31
Cn-05	Frequency - Midpoint	0.1 Hz	0.0 - 400.0	3.0 <i>See Note 1</i>		2.31
Cn-06	Voltage - Midpoint	0.1 V	0.0 - 255.0 (230V) 0.0 - 510.0 (460V) 0.0 - 730.0 (575V)	17.2 (230V) 34.4 (460V) 575.0 (575V) <i>See Note 1</i>		2.31
Cn-07	Frequency - Min.	0.1 Hz	0.0 - 400.0	1.5 <i>See Note 1</i>		2.31
Cn-08	Voltage - Min.	0.1 V	0.0 - 255.0 (230V) 0.0 - 510.0 (460V) 0.0 - 730.0 (575V)	11.5 (230V) 23 (460V) 575.0 (575V) <i>See Note 1</i>		2.31
Cn-09	Motor Rated Current	0.1 A	(10% - 200% of inverter rated current) <i>See Note 3</i>	See App. 3, Table A3-1		2.35
Cn-10	DC Injection Braking Start Freq.	0.1 Hz	0.0 - 10.0	1.5 <i>See Note 1</i>		2.8B, 2.8D
Cn-11	DC Injection Braking Current	1 %	0 - 100	50 <i>See Note 4</i>		2.8B, 2.8C
Cn-12	DC Injection Time at Stop	0.1 s	0.0 - 25.5	0.0		2.8A, 2.8B
Cn-13	DC Injection Time at Start	0.1 s	0.0 - 25.5	0.0		2.8B

Table A1-4. Control Constants (Cn-XX) - Continued

CONSTANT NUMBER	DATA NAME	INCREMENT	SETTING RANGE	FACTORY SETTING	USER SETTING	PARA. REF.
Cn-14	Frequency Command Upper Limit	1 %	0 - 109	100		2.14
Cn-15	Frequency Command Lower Limit	1 %	0 - 109	0		2.14
Cn-16	Prohibit Frequency 1	0.1 Hz	0.0 - 400.0	0.0		2.7A
Cn-17	Prohibit Frequency 2	0.1 Hz	0.0 - 400.0	0.0		2.7A
Cn-18	Prohibit Frequency 3	0.1 Hz	0.0 - 400.0	0.0		2.7A
Cn-19	Prohibit Frequency Deadband	0.1 Hz	0.0 - 25.5	1.0		2.7B
Cn-20	Operator Display Mode Reference and Indication	1	0 - 39999	0		2.9
Cn-21	Speed Coincidence Frequency	0.1 Hz	0.0 - 400.0	0.0		2.23, 2.21
Cn-22	Speed Coincidence Bandwidth	0.1 Hz	0.0 - 25.5	2.0		2.23, 2.21
Cn-23	Carrier Frequency Upper Limit	0.1 kHz	0.4 - 15.0	See Note 3		2.36
Cn-24	Carrier Frequency Lower Limit	0.1 kHz	0.4 - 15.0	See Note 3		2.36
Cn-25	Frequency Proportion Gain	1	0 - 99	0		2.36
Cn-26	Overtorque Detection Level	1 %	30 - 200	160		2.18, 2.22
Cn-27	Overtorque Detection Time	0.1 s	0.0 - 25.5	0.1		2.22
Cn-28	Stall Prevention Level During Accel (Constant Torque Region)	1 %	30 - 200	170		2.29
Cn-29	Stall Prevention Limit During Accel (Constant HP Region)	1 %	30 - 200	50		2.29
Cn-30	Stall Prevention Level at Set Frequency	1 %	30 - 200	160		2.29
Cn-31	Motor-to-Motor Cable Resistance	0.001 Ω	0.000 - 65.535	See Note 3		--
Cn-32	Torque Compensation Iron Loss	1 W	0 - 65535	See Note 3		--
Cn-33	Torque Compensation Limiter	1 V	0 - 50 (230V) 0 - 100 (460V)	See Note 3		--
Cn-34	Motor No-load Current	1 %	0 - 99	30 See Note 2		2.35
Cn-35	Slip Compensation Primary Delay Time	0.1 s	0.0 - 25.5	2.0		2.35
Cn-36	No. of Auto-Restart Attempts	1	0 - 10	0		2.5A

Table A1-4. Control Constants (Cn-XX) - Continued

CONSTANT NUMBER	DATA NAME	INCREMENT	SETTING RANGE	FACTORY SETTING	USER SETTING	PARA. REF.
Cn-37	Momentary Power Failure Ride-thru Time	0.1 s	0.0 - 2.0	See Note 3		--
Cn-38	Speed Search Operation Level	1 %	0 - 200	150		2.28B
Cn-39	Speed Search Decel Time	0.1 s	0.0 - 25.5	2.0 See Note 5		2.28C
Cn-40	Min. Base Block Time	0.1 s	0.0 - 5.0	See Note 3		2.28D
Cn-41	V/f During Speed Search	1 %	0 - 100	100		2.28E
Cn-42	Voltage Recovery Time	0.1 s	0.1 - 5.0	0.3		2.28F

NOTES:

1. Initial value differs depending on V/f curve selected (Sn-02 set value). Values shown are initial values when Sn-02 is set to **0F**.
2. Motor rated current (Cn-09) is the 100% level. Setting range: 10 to 200% of GPD 503 rated current.
3. Initial value depends on GPD 503 capacity.
4. Set value ≤ 50%: carrier frequency = 8 KHz; set value > 50%: carrier frequency = 1 KHz.
5. If set to zero, speed search will be disabled.

Table A1-5. Monitor Displays (Un-XX)

CONSTANT NO.	MONITOR ITEM	DISPLAY EXAMPLE	PARA. REF.
Un-01	Frequency reference (Hz)	60.00	2.17
Un-02	Output frequency (Hz)	60.00	2.17
Un-03	Output current (A)	12.5A	2.17
Un-04	Voltage reference (Vac)	460v	2.17
Un-05	DC voltage (VPN)	Pn650	2.17
Un-06	Output power (kW)	(-) .75	2.17
Un-07	Input terminal status	CIIII ◇	2.17
Un-08	Output signals status	o II Δ	2.17
Un-09	LED lamp check	8.8.8.8.8.	2.17
Un-10	Control Section Software PROM No. Lower 5 Digits : NSG <u>6XXXXX</u>	16 142	

◇ Actual display appearance:

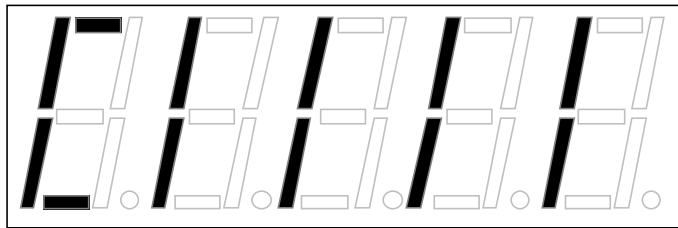

Δ Actual display appearance:

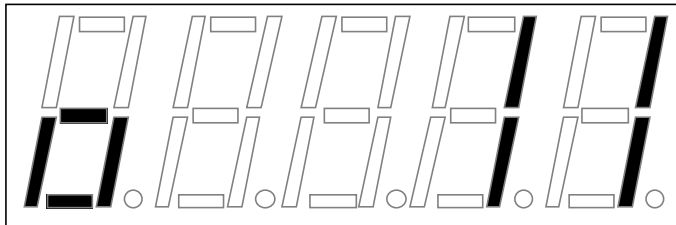

NOTE

These two displays are explained in paragraph 2.17.

Appendix 2. SPECIFICATIONS

Table A2-1. Standard Specifications

SECTION A. Input Voltage Related Specifications							
230V Class							
Input Power		Voltage : 3 Phase 200 / 208 / 220 / 230 VAC +/- 10%					
		Frequency : 50 / 60 Hz +/- 5%					
Output Power		Voltage : 0 - 230V (Output cannot be greater than input)					
		Frequency: 0 - 400 Hz (V/Hz pattern selectable)					
MODEL NO.	RATED kVA	CT HP	100% CONT. OUTPUT AMPS 1	VT HP	100% CONT. OUTPUT AMPS 2	RATED INPUT AMPS	MCCB RATED AMPS
DS305	2.1	1	4.8	1	5.4	5.3	10
DS302	2.7	2	6.4	2	7.2	7.0	20
DS306	4.1	3	9.6	3	10.8	10.6	20
DS307	6.9	5	16	5	18	18	30
DS308	10.3	7.5	24	7.5/10	27	26	50
DS309	13.7	10	32	15	36	35	60
DS310	20.6	15	48	20	54	53	100
DS311	27.4	20	64	25	72	70	100
DS322	34.0	25	80	30	90	88	150
DS323	41.0	30	96	40	108	106	150
DS2040	54	40	130	50	146	143	225
GPD503-2L40	54	40/50	130	50	146	143	225
DS2050	68	50	160	60	180	176	225
GPD503-2L50	68	60	160	60	180	176	225
DS2060	78	60	183	75	205	201	300
GPD503-2L60	78	60	183	75	205	201	300
DS2075	95	75	224	100	252	246	400
GPD503-2L75	95	75	224	100	252	246	400
DS2100	130	100	300	150	337	330	600
GPD503-2L100	130	100	300	125	337	330	600
460V Class							
Input Power		Voltage : 3 Phase 380 / 400 / 415 / 440 / 460 VAC +/- 10%					
		Frequency : 50 / 60 Hz +/- 5%					
Output Power		Voltage : 0 - 460V (Output cannot be greater than input)					
		Frequency: 0 - 400 Hz (V/Hz pattern selectable)					
MODEL NO.	RATED kVA	CT HP	100% CONT. OUTPUT AMPS 1	VT HP	100% CONT. OUTPUT AMPS 2	RATED INPUT AMPS	MCCB RATED AMPS
DS313	2.2	1	2.6	1	2.9	2.9	5
DS304	3.4	2	4.0	2	4.5	4.4	10
DS314	4.1	3	4.8	3	5.4	5.3	10
DS315	6.9	5	8	5	9.0	8.8	20
DS316	10.3	7.5	12	7.5/10	13.5	13.0	20
DS317	13.7	10	16	15	18	18.0	30
DS318	20.6	15	24	20	27	26.0	50
DS326	27.4	20	32	25	36	35.0	60
DS325	34.0	25	40	30	45	44.0	80
DS330	41.0	30	48	40	54	53.0	100
DS340	54.0	40	64	50	72	70.0	100
DS350	68.0	50	80	60	90	88.0	150
DS360	82.0	60	96	75	108	106.0	150
DS075	115	75	128	100	144	141	225
GPD503-4L75	115	75/100	128	100	144	141	225
DS100	140	100	165	150	180	181	300
GPD503-4L100	140	100	165	150	180	181	300

(460V Class continued on next page)

Table A2-1. Standard Specifications (Continued)

SECTION A. Input Voltage Related Specifications (Continued)							
460V Class (Continued)							
MODEL NO.	RATED kVA	CT HP	100% CONT. OUTPUT AMPS 1	VT HP	100% CONT. OUTPUT AMPS 2	RATED INPUT AMPS	MCCB RATED AMPS
DS150	200	150	224	200	252	246	400
GPD503-4L150	200	150	224	200	252	246	400
DS200	260	200	300	250	337	330	600
GPD503-4L200	260	200	300	250	337	330	600
DS250	300	250	375	300	422	372	600
DS303	400	300	450	400	506	496	800
DS400	535	400	600	500	675	663	1000
575V Class							
Input Power		Voltage : 3 Phase; 500 / 575 / 600 VAC +/- 10% Frequency : 50 / 60 Hz +/- 5%					
Output Power		Voltage : 0 - 600V or 0 - 575V (Output cannot be greater than input) Frequency: 0 - 400 Hz (V/Hz pattern selectable)					
MODEL NO.	RATED kVA	CT HP	100% CONT. OUTPUT AMPS 1	VT HP	100% CONT. OUTPUT AMPS 3	RATED INPUT AMPS	MCCB RATED AMPS
DS5003	2	2	3.5	3	3.9	4.3	10
DS5004	3	3	4.1	3	4.6	5.1	10
DS5006	5	5	6.3	5	7	7.7	20
DS5009	7.5	7.5	9.8	7.5	11.0	12.1	20
DS5012	10	10	12.5	10	14	15.4	20
DS5017	15	15	17	15	19	21	30
DS5022	20	20	22	20	25	28	50
DS5027	25	25	27	25	30	33	60
DS5032	30	30	32	30	36	40	60
DS5043	40	40	41	40	46	51	100
DS5054	50	50	52	50	58	64	100
DS5064	60	60	62	60	69	76	100
DS5081	75	75	77	75	86	95	150
DS5112	100	100	99	100	111	122	225
DS5130	125	125	130	150	145	160	225
DS5172	150	150	172	200	192	211	300
DS5202	200	200	200	250	224	246	400
SECTION B. ALL GPD 503s							
Control Characteristics	Control Method		Sine Wave PWM				
	Frequency Accuracy		Digital command: 0.01% (-10 to 40°C) (+14 to 104°F)				
			Analog command: 0.1% (15 to 35°C) (59 to 95°F)				
	Frequency Resolution		Digital Operator reference: 0.01 Hz Analog reference: 0.06 Hz/60Hz				
	Output Frequency Resolution		0.01 Hz				
	Frequency Setting Signal		0 to 10 VDC (20K Ohms), 4-20mA (250 Ohms)				
	Accel / Decel Time		0.1 to 6000 sec (Accel / Decel time setting independently)				

Table A2-1. Standard Specifications (Continued)

SECTION B. ALL GPD 503s (Continued)		
Control Characteristics (continued)	Braking Torque	Approximately 20%
	V/F Pattern Selection	15 Standard Patterns: 4 for general purpose; 4 for high starting torque; 4 for fans and pumps; 3 for machine tools. 1 custom pattern: defined by control constant settings.
Protective Functions	Motor Overload Protection	Electronic thermal overload relay
	Instantaneous Overcurrent	Motor coasts to a stop at approximately 200% rated current.
	Fuse Blown Protection	Motor coasts to a stop by blown fuse.
	Overload	Motor coasts a stop after 60 sec. overload condition.
	Overvoltage	Motor coasts to a stop if GPD 503 DC bus voltage exceeds 400 V (230V unit), 800V (460V unit), 1040V (575V unit).
	Undervoltage	Motor coasts to a stop if GPD 503 DC bus voltage drops to 210 V or below (230V unit), 420V or below (460V unit), 546V or below (575V unit).
	Momentary Power Failure	Factory setting provides for motor to coast to a stop after momentary power failure of more than 15 ms. Can be reprogrammed to allow continuous operation (ride-through) during power failure of up to 2 seconds (see Note 4).
	Heatsink Overheat	Thermostat
	Stall Prevention	Stall prevention at acceleration/deceleration and constant speed operation.
	Ground Fault	Provided by electronic circuit.
Power Charge Indication	"CHARGE" lamp remains lit until bus voltage drops below 50 V.	
Environmental Conditions	Location	Indoor (protected from corrosive gases and dust).
	Ambient Temperature	-10 to 40°C (+14 to 104°F)
	Storage Temperature (Note 5)	-20 to 60°C (-4 to 140°F)
	Humidity	90% RH (no condensation)
	Vibration	1 G at less than 20 Hz, up to 0.2 G at 20 to 50 Hz.

NOTES:

1. Overload capacity: 150% of rated for 60 sec.
2. Overload capacity: 125% of rated for 60 sec.
3. Overload capacity: 115% of rated for 60 sec.
4. For a 230/460 V GPD 503 less than 5HP, ride-through function up to 2 second momentary power failure requires connection of an external capacitor unit between external main circuit terminals B1/+ and -.
5. Temperature during shipping. Storing in this temperature for a long period may deteriorate main circuit capacitor.

Appendix 3. GPD 503 CAPACITY

System Constant Sn-01 (GPD 503 Capacity) is factory preset per the voltage and horsepower ratings of the GPD 503. Table A3-1 identifies the set value, per Model Number. If the Control PCB is replaced, the new board MUST have Sn-01 programmed to the appropriate set value BEFORE again operating the GPD 503 in the Drive mode.

Table A3-1. GPD 503 Capacity

Sn-01 Set Value	Drive Model No.	Max Motor Output HP - (kW)		Motor Rated Current (Amps) (Cn-09) (See Note 1)	GPD 503 Rated Current (Amps) (Reference Current For Setting Constants; See Note 2)
2 3 0 V					
01	DS305	1	(0.75)	3.3	4.8
02	DS302	2	(1.5)	6.1	6.4
03	DS306	3	(2.2)	8.5	9.6
04	DS307	5	(3.7)	14.1	16
05	DS308	7.5	(5.5)	20.7	24
06	DS309	10	(7.5)	27.5	32
07	DS310	15	(11)	39.7	48
08	DS311	20	(15)	53.0	64
09	DS322	25	(18.5)	65.8	80
0A	DS323	30	(22)	77.2	96
0b	DS2040	40	(30)	105	130
0b	GPD503-2L40	40/50	(30)	105	130
0C	DS2050	50	(37)	131	160
0C	GPD503-2L50	60	(37)	131	160
0d	DS2060	60	(45)	156	183
0d	GPD503-2L60	60	(45)	156	183
0E	DS2075	75	(55)	190	224
0E	GPD503-2L75	75	(55)	190	224
0F	DS2100	100	(75)	240	300
0F	GPD503-2L100	100	(75)	240	300
4 6 0 V					
21	DS313	1	(0.75)	1.7	2.6
22	DS304	2	(1.5)	3.1	4.0
23	DS314	3	(2.2)	4.2	4.8
24	DS315	5	(3.7)	6.8	8.0
25	DS316	7.5	(5.5)	10.2	12
26	DS317	10	(7.5)	13.4	16
27	DS318	15	(11)	20.1	24
28	DS326	20	(15)	26.7	32
29	DS325	25	(18.5)	33.4	40
2A	DS330	30	(22)	38.5	48
2b	DS340	40	(30)	52.5	64

See NOTES on next page.

Table A3-1. GPD 503 Capacity - Continued

Sn-01 Set Value	Drive Model No.	Max Motor Output CT HP - (kW)	Motor Rated Current (Amps) (Cn-09) (See Note 1)	GPD 503 Rated Current (Amps) (Reference Current For Setting Constants; See Note 2)
4 6 0 V (Continued)				
2C	DS350	50 (37)	65.5	80
3F	DS360	60 (45)	78.0	96
2E	DS075	75 (55)	98	128
2E	GPD503-4L75	75/100 (55)	98	128
2F	DS100	100 (75)	120	165
2F	GPD503-4L100	100 (75)	120	165
31	DS150	150 (110)	175	224
31	GPD503-4L150	150 (110)	175	224
33	DS200	200 (160)	245	300
33	GPD503-4L200	200 (160)	245	300
34	DS250	250 (185)	306	375
35	DS303	300 (220)	365	450
36	DS400	400 (300)	490	600
5 7 5 V				
42	DS5003	2 (1.5)	2.7	3.5
43	DS5004	3 (2.2)	3.9	4.1
44	DS5006	5 (3.7)	6.1	6.3
45	DS5009	7.5 (5.5)	9.0	9.8
46	DS5012	10 (7.5)	11.0	12.5
47	DS5017	15 (11)	17.0	17.0
48	DS5022	20 (15)	22.0	22.0
49	DS5027	25 (18.5)	27.0	27.0
4A	DS5032	30 (22)	32.0	32.0
4b	DS5043	40 (30)	41.0	41.0
4C	DS5054	50 (37)	52.0	52.0
4d	DS5064	60 (45)	62.0	62.0
4E	DS5081	75 (55)	77.0	77.0
4F	DS5112	100 (75)	99	99.0
50	DS5130	125 (90)	125	130
51	DS5172	150 (110)	144	172
52	DS5202	200 (160)	192	200

NOTES:

1. Listed Cn-09 setting represents 100% motor rated current, as determined by Sn-01 set value.
2. See description of "Overtorque Detection" (Cn-26) in Section 2.

Appendix 4. DIODE AND TRANSISTOR MODULE RESISTANCE TEST

DIODE MODULE

Measure the resistance across the module terminals with a volt-ohm meter. Set the meter at the X1 range. The measured resistance should be within the values listed in Table A4-1.

Table A4-1. Diode Module Resistances

+	-	NORMAL READING (OHMS)	ABNORMAL READING (OHMS)	+	-	NORMAL READING (OHMS)	ABNORMAL READING (OHMS)
ON	ON			ON	ON		
L1	P	10 to 50	0 or INFINITE	L1	N	INFINITE	LESS THAN
L2	P			L2	N		
L3	P			L3	N		
N	L1			P	L1		
N	L2			P	L2		
N	L3			P	L3		
				P	N		

RESISTANCE TEST FOR 3Ø CONVERTER MODULES (BRIDGE RECT)

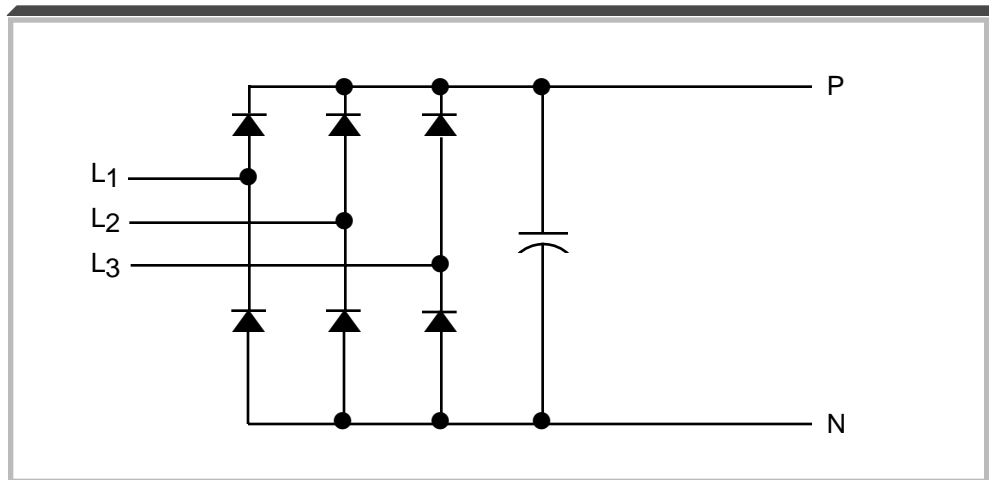

VOM RESISTANCE SCALE RX1
 + IS THE POSITIVE POLARITY LEAD*
 - IS THE NEGATIVE POLARITY LEAD

*THE VOM RED LEAD IS NOT NECESSARILY THE POSITIVE POTENTIAL IN THE RESISTANCE MODE. FOR THESE TESTS THE + LEAD REFERS TO THE POSITIVE POTENTIAL. MAKE SURE YOU KNOW WHICH POLARITY YOU HAVE ON YOUR VOM.

IGBT TRANSISTOR MODULE

Measure the resistance across the module terminals with a volt-ohm meter. Set the meter to the X1 range. Measured resistance should be within the values listed in Table A4-2.

Table A4-2. Transistor Module Resistances

+	-	NORMAL READING (OHMS)	ABNORMAL READING (OHMS)	+	-	NORMAL READING (OHMS)	ABNORMAL READING (OHMS)
ON	ON			ON	ON		
P+	T1	INFINITE	0	G1A	T1	INFINITE	LESS THAN 1M
P+	T2						
P+	T3						
T1	N-						
T2	N-						
T3	N-						
T1	P+	5 to 50 **	0 or INFINITE	T1	G1A	INFINITE	LESS THAN 1M
T2	P+						
T3	P+						
N-	T1						
N-	T2						
N-	T3						

RESISTANCE TEST FOR 3Ø TRANSISTOR MODULES

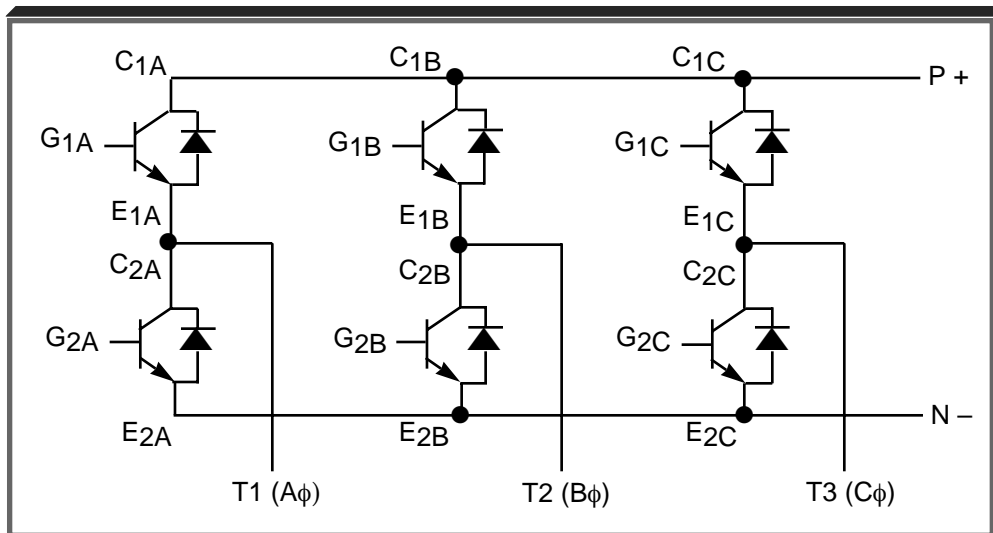

VOM RESISTANCE SCALE R x 1
 + IS THE POSITIVE POLARITY LEAD *
 - IS THE NEGATIVE POLARITY LEAD

* THE VOM RED LEAD IS NOT NECESSARILY THE POSITIVE POTENTIAL IN THE RESISTANCE MODE. FOR THESE TESTS THE + LEAD REFERS TO THE POSITIVE POTENTIAL. MAKE SURE YOU KNOW WHICH POLARITY YOU HAVE ON YOUR VOM.

** OR 0.3 TO 0.7, FOR DIGITAL METER ON (DIODE DROP) SCALE.

Appendix 5. GPD 503 DIMENSIONS

Table A5-1 lists dimensions for the GPD 503 in its standard enclosure. For information on other types of enclosures available, consult your MagneTek representative.

Table A5-1. GPD 503 Size and Weight

RATING			ENCLOSURE TYPE	PHYSICAL DIMENSIONS (IN.)			MOUNTING DIM. (IN.)		WEIGHT (LB)	
VOLTS	HP			H	W	D	H1	W1		
	CT	VT								
2 3 0	1	1	NEMA 1	11.97	8.05	5.12	11.22	7.09	9	
	2	2		11.97	8.05	5.12	11.22	7.09	9	
	3	3		11.97	8.05	6.50	11.22	7.09	16	
	5	5	NEMA 1	11.97	8.05	6.50	11.22	7.09	16	
		7.5		7.5/10	13.94	8.05	7.87	13.19	7.09	22
		10		15	13.94	8.05	7.87	13.19	7.09	22
	15	20	NEMA 1	23.62	11.81	9.65	19.69	11.02	57	
		20		25	25.59	14.76	9.84	21.65	13.98	71
		25		30	27.56	18.50	10.24	23.62	17.52	95
		30		40	29.13	18.50	10.24	23.62	17.52	95
		40		50	Protected Chassis	26.57	16.73	11.02	25.78	12.40
	50	60	31.49	18.70		11.02	30.70	14.76	130	
	60	75	31.49	18.70		11.02	30.70	14.76	143	
	75	100	31.49	18.70		11.02	30.70	14.76	143	
	100	120	31.49	18.70	11.02	30.70	14.76	143		
"L" units *	40/50	50	Protected Chassis	Consult MagneTek for dimensions and weight						
	60	60								
	60	75								
	75	100								
	100	125								
4 6 0	1	1	NEMA 1	13.94	8.05	6.50	13.19	7.09	16	
	2	2		13.94	8.05	6.50	13.19	7.09	16	
	3	3		13.94	8.05	6.50	13.19	7.09	16	
	5	5		13.94	8.05	6.50	13.19	7.09	22	
	7.5	7.5/10		13.94	8.05	7.87	13.19	7.09	22	
	10	15		13.94	8.05	7.87	13.19	7.09	22	
	15	20	NEMA 1	23.62	11.81	10.31	19.69	11.02	60	
		20		25	23.62	11.81	10.31	19.69	11.02	62
		25		30	27.56	18.50	10.31	23.62	17.52	86
	30	40	NEMA 1	27.56	18.50	10.31	23.62	17.52	86	
		40		50	34.45	19.29	11.26	30.51	18.31	130
		50		60	34.45	19.29	11.26	30.51	18.31	137
		60		75	44.29	25.98	11.26	39.67	24.80	227
	75	100	Protected Chassis	36.42	22.63	11.00	35.42	18.70	194	
		100		150	36.42	22.63	11.00	35.42	18.70	194
150		200		36.42	22.63	13.00	35.42	18.70	229	
200		250		53.54	23.62	17.83	52.16	21.65	374	
"L" units *	75/100	100	Protected Chassis	44.49	18.11	12.99	31.30	13.78	203	
	100	150		44.49	18.11	12.99	31.30	13.78	203	
	150	200		50.79	22.84	13.98	35.24	17.52	315	
	200	250		50.79	22.84	14.96	35.24	17.52	346	
	250	300		Protected Chassis	57.09	37.40	17.12	55.12	29.53	792
300	400	57.09	37.40		17.12	55.12	29.53	792		
400	500	63.00	37.40		17.12	61.02	29.53	900		

* Refers to GPD 503 drives with "L" appearing in their Model Numbers.

Table A5-1. GPD 503 Size and Weight - Continued

RATING			ENCLOSURE TYPE	PHYSICAL DIMENSIONS (IN.)			MOUNTING DIM. (IN.)		WEIGHT (LB)
VOLTS	HP			H	W	D	H1	W1	
	CT	VT							
5 7 5	2	3	NEMA 1	13.94	8.05	6.50	13.19	7.09	15
	3	3		13.94	8.05	6.50	13.19	7.09	15
	5	5	NEMA 1	13.94	8.05	7.87	13.19	7.09	22
	7.5	7.5		13.94	8.05	7.87	13.19	7.09	22
	10	10		13.94	8.05	7.87	13.19	7.09	22
	15	15	NEMA 1	23.62	12.80	10.83	23.03	9.84	77
	20	20	NEMA 1	29.53	15.75	11.22	28.74	11.81	99
	25	25		29.53	15.75	11.22	28.74	11.81	99
	30	30		29.53	15.75	11.22	28.74	11.81	99
	40	40	NEMA 1	33.46	22.64	11.81	32.48	18.70	159
	50	50		33.46	22.64	11.81	32.48	18.70	159
	60	60		33.46	22.64	11.81	32.48	18.70	159
	75	75	NEMA 1	41.34	22.64	12.80	40.35	18.70	205
	100	100	NEMA 1	41.97	22.64	12.80	40.35	18.70	205
	125	150	Protected Chassis	49.21	22.64	12.99	48.23	18.70	265
150	200	62.99		22.64	13.98	61.81	18.70	331	
200	200	62.99		22.64	13.98	61.81	18.70	331	

Appendix 6. SPARES

GPD 503 - 230 VAC Rating - 1HP CT (1HP VT) thru 30HP CT (40HP VT)

Part No.	Transistor Module										Diode Module					Base Drive PCB							Control PCB		Fan				DC Bus Fuse														
502078	02	03	04	05	06	07	08	09	10	20	21	22	23	24	30	31	32	33	34	35	36	37	56	57	46	47			49														
501848																																					28	29	30	31	32	59	36
501739														62																	01	02											
Model No.																																											
DS305	1									1					1								1						1														1
DS302		1									1					1							1						1														1
DS306			1									1					1						1			1				1													1
DS307				1								1						1					1			1					1							1					1
DS308					3								1						1					1		1							1										1
DS309						3								1						1				1		1								1									1
DS310							3							1							1			1		1		1						1									1
DS311								3													1			1		1		1							1							1	1
DS322									6													1		1				1								1						1	1
DS323									6													1		1				1								1						1	1

GPD 503 - 230 VAC Rating - 40HP CT (50HP VT) thru 100HP CT (125HP VT)

Part No.	Transistor Module		Diode Module				Gate Driver PCB				Control PCB		Fan		DC Bus Fuse			
502079	05	06					35	36	49	50				19				
501848						12											60	90
502078												58						
Model No.																		
DS2040	6					3			1		1		2				1	
DS2050		6				6				1	1		2					1
DS2060	12					6		1			1		2			1		
DS2075	12					6		1			1		2			1		
DS2100		12				9			1		1		2			1		

GPD 503 - 460 VAC Rating - 1HP CT (1HP VT) thru 60HP CT (75HP VT)

Part No.	Transistor Module									Diode Module				Base Drive PCB							Chopper PCB	Control PCB	Fan		DC Bus Fuse												
502078	11	12	13	14	15	16	17	18	19	25	26	27	28	59	60	61	62	42	43	44	45	53	57	46	48	50	51	52									
501848													17	18																							
501739																																					
Model No.																																					
DS313	1									1					1									1	1		1										2
DS304		1								1						1								1	1		1										2
DS314		1								1						1								1	1		1										2
DS315			3								1						1							1	1			1									2
DS316				3							1							1						1	1			1									2
DS317				3							1							1						1	1			1									2
DS318					3								1						1				1	1		1					1						2
DS326						3						1							1				1	1		1						1					2
DS325							3							1						1			1	1		1		1				1					2
DS330								3					3								1			1		1		1				1					2
DS340									6				3								1			1		1		1					1				2
DS350									6				3								1			1		1		1						1			2
DS360									6				3								1			1		1		1						1			2

IMPORTANT

Numbers represent total quantity used in the Drive. To determine Spares List, factory suggests using listed value for quantities 2 and below. If listed value is greater than 2, factory suggests 1/3 of total.

GPD 503 - 460 VAC Rating - 75HP CT (100HP VT) thru 200HP CT (250HP VT)

Part No.	Transistor Module						Diode Module		Gate Driver PCB				Control PCB	Fan		DC Bus Fuse					
502079__			07	08	09		14	15	60	61	62	63		19	71	72	73				
502078__													58								
501739__																					98
Model No.																					
DS075			6				6		1				1	2	1						
DS100			6				6			1			1	2		1					
DS150				12			9				1		1	2							1
DS200					12			6				1	1	2			1				

GPD 503 - 460 VAC Rating - 250HP CT (300HP VT) thru 400HP CT (500HP VT)

Part No.	Transistor Module				Main Diode Ckt	Main Drive PCB			Sub Drive PCB			Control PCB	Fan Unit		DC Bus Fuse			
502079__				10	11	13	15	16	17	27	25	26	28	58	29	81	82	83
502078__																		
Model No.																		
DS250						24				1			1	1	3			12
DS303					24		6		1		1		1	1	3			12
DS400					24		9		1			1		1	3			12

GPD 503 - 575 VAC Rating - 2HP CT (3HP VT) thru 30HP CT (30HP VT)

Part No.	Transistor Module				Diode Module		Gate Drive PCB					Control PCB	Fan			DC Bus Fuse		
502050__				41	42	45	47										50	52
502078__													57					
502080__		12	13					05	06	07	08	09		24	25	26	16	17
Model No.																		
DS5003		1				1		1					1	1			1	
DS5004		1				1		1					1	1			1	
DS5006			3			1			1				1	1			1	
DS5009			3			1			1				1	1			1	
DS5012			3			1				1			1	1			1	
DS5017				3		1					1		1	1			1	
DS5022					3		1					1	1		1			1
DS5027					3		1					1	1		1			1
DS5032					3		1					1	1		1			1

GPD 503 - 575 VAC Rating - 40HP CT (40HP VT) thru 100HP CT (100HP VT)

Part No.	Transistor Module				Diode Module		Gate Drive PCB				Control PCB	Fan		DC Bus Fuse				
502050__				43	44	48										53		
502078__												58						
502080__								10						27				
Model No.																		
DS5043			6			3		1					1	2			1	
DS5054			6			3		1					1	2			1	
DS5064			6			3		1					1	2			1	
DS5081				6		3		1					1	2			1	
DS5112				6		3		1					1	2			1	

GPD 503 - 575 VAC Rating - 125HP CT (150HP VT) thru 200HP CT (200HP VT)

Part No.	Transistor Module				Main Diode Ckt	Main Drive PCB			Sub Drive PCB			Control PCB	Fan Unit		DC Bus Fuse			
502078__												58						
502080__		21	22			23		11			14	15		27		18	19	20
Model No.																		
DS5130		12				6		1			1		1	2		1		
DS5172			12			9		1				1	1	2		1		
DS5202			12			9		1				1	1	2		1		

IMPORTANT

Numbers represent total quantity used in one Drive. To determine adequate inventory of spare parts, MagneTek suggests using listed value for quantities 2 and below. If listed value is greater than 2, factory suggests 1/3 of total listed.

Appendix 7. DYNAMIC BRAKING CONNECTIONS

GENERAL. Dynamic braking (DB) enables the motor to be brought to a smooth and rapid stop. This is achieved by dissipating the regenerative energy of the AC motor across the resistive components of the Dynamic Braking option. For further details on dynamic braking operation, see the instruction sheet shipped with dynamic braking components.

The GPD 503 in 230V 1-10HP (CT), 460V 1-20HP (CT), or 575V 5-25HP (CT) range has an integral braking transistor; all higher rated drives require the use of external Braking Units (also referred to as Braking Modules) which provide the braking transistor circuitry. In addition, to make use of the Dynamic Braking function requires adding a heat sink mount Braking Resistor (for 3% duty cycle; only available for the 230 1-5HP (CT) or 460V 1-3HP (CT) range) or external Braking Resistor Units (for 10% duty cycle).

Since the 3% Braking Resistor mounts directly to the drive's heat sink, any braking resistor overheating is sensed as a drive heatsink overtemperature fault. But for Braking Resistor Units, interconnection to external control circuitry is necessary to ensure that braking resistor overheating is communicated to the drive as a fault condition.

Available MagneTek dynamic braking components for 230V and 460V units are listed in Table A7-1. To select dynamic braking components for 575V units, refer to Table A7-2.

Table A7-1. GPD 503 DB Components

For 230V GPD 503s						For 460V GPD 503s										
DRIVE HP (CT)	BRAKING MODULE		HS RESISTOR ⁽¹⁾	BRAKING UNIT		DRIVE HP (CT)	BRAKING MODULE		HS RESISTOR ⁽¹⁾	BRAKING UNIT						
	PART NO.	QTY Req'd	PART NO.	PART NO.	QTY Req'd		PART NO.	QTY Req'd	PART NO.	PART NO.	QTY Req'd					
1	N/A	—	50185430	50185130	1	1	N/A	—	50185530	50185330	1					
2			50185431	50185131	1	2			50185531	50185331	1					
3			50185432	50185132	1	3			50185532	50185332	1					
5			50185433	50185133	1	5			N/A	50185333	1					
7.5			N/A	50185134	1	7.5				50185334	1					
10				50185135	1	10				50185335	1					
15			50185034	1	N/A	51085136			1	15	N/A	—	50185336	1		
20			50185034	1		50185137			1	20			50185337	1		
25			50185035	1		50185138			1	25			50185234	1	50185338	1
30			50185035	1		50185139			1	30			50185234	1	50185339	1
40	50185034	2	50185137	2		40	50185234	1	50185340	1						
50	50185034	2	50185137	2		50	50185235	1	50185341	1						
60	50185035	2	50185139	2		60	50185235	1	50185342	1						
75	50185035	2	50185139	2		75	50185234	2	50185340	2						
100	50185035	3	50185139	3		100	50185235	2	50185342	2						
						150	50185234	3	50185340	3						
						200	50185235	4	50185342	4						
						250	50185235	5	50185342	5						
						300	50185235	5	50185342	5						
						400	50185235	6	50185342	6						

(1) When the heat sink mount Braking Resistor is used, DO NOT wire a Braking Unit to the drive.

Table A7-2. GPD 503 DB Components

For 575V GPD 503s					
DRIVE HP (CT)	BRAKING MODULE		BRAKING RESISTOR		BRAKING TORQUE (%)
	PART NO.	QTY Reqd	POWER WATTS (EACH)	RESISTANCE OHMS (EACH)	
2		—	560	150	180
3			560	150	180
5			560	150	180
7.5			560	150	125
10			750	100	140
15			1100	75	125
20			1500	50	140
25			2300	40	140
30	50185236	1	2800	38	125
40	50185236	1	3900	33	110
50	50185236	1	4900	27	110
60	50185236	2	5900	22	110
75	50185236	2	7200	18	110
100	50185236	2	9800	13.6	105
125	50185236	3	12,000	11	110
150	50185236	3	15,000	9	110
200	50185236	4	21,000	6.8	100

INSTALLATION

This option must be installed by a **TECHNICALLY QUALIFIED INDIVIDUAL** who is familiar with this type of equipment and the hazards involved.

WARNING

Hazardous voltage can cause severe injury or death. Lock all power sources feeding the drive in the "OFF" position.

CAUTION

Failure to follow these installation steps may cause equipment damage or personnel injury.

Preliminary Procedures

1. Disconnect all electrical power to the drive.
2. Remove drive front cover.
3. Use a voltmeter to verify that voltage is disconnected from incoming power terminals.

Braking Resistor (Heat Sink Mount) Installation

1. Remove the drive from its mounting for access to the rear of the heat sink.
2. Mount the Braking Resistor on the back of the drive's heat sink (see Figure A7-1).
3. Reinstall the drive in its mounting position.
4. Connect the Braking Resistor's leads to drive terminals according to Figure A7-2.
5. Proceed to step 9 on page A7-8.

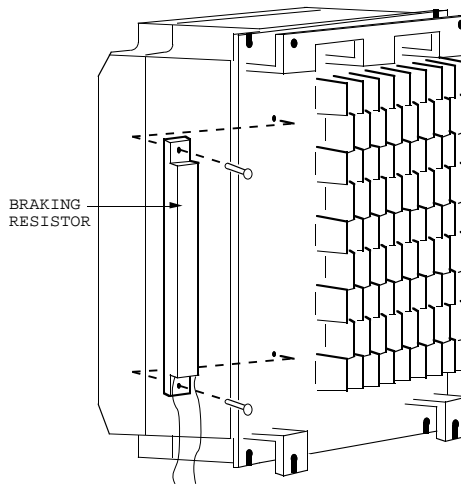

Figure A7-1. Mounting Braking Resistor on Heat Sink

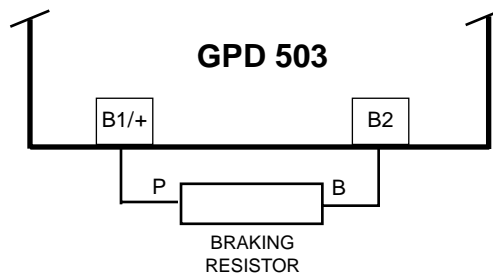

Figure A7-2. Lead Connections For Braking Resistor (Heat Sink Mounted)

Braking Resistor Unit Installation (for 230V 1-10HP(CT), 460V 1-20HP(CT), 575V 2-25HP(CT) drives)

IMPORTANT

Since the Braking Resistor Unit generates heat during dynamic braking operation, install it in a location away from other equipment which emits heat.

1. Mount the Braking Resistor Unit on a vertical surface, maintaining a minimum 1.18 inch (30 mm) clearance on each side and a minimum 5.91 inch (150 mm) clearance top and bottom.

2. Remove the Braking Resistor Unit front cover to access its terminal block. Connect the Braking Resistor Unit to the drive and to external control circuitry according to the chart at right and Figure A7-3.

Terminals	B, P	1, 2 *
Lead Size (AWG)	12-10	18-14 *
Lead Type	600V ethylene propylene rubber insulated, or equivalent	
Terminal Screw	M4	

* Power leads for the Braking Resistor Unit generate high levels of electrical noise; these signal leads must be grouped separately.

4. Reinstall and secure Braking Resistor Unit front cover and drive front cover.

5. Proceed to step 10 on page A7-8.

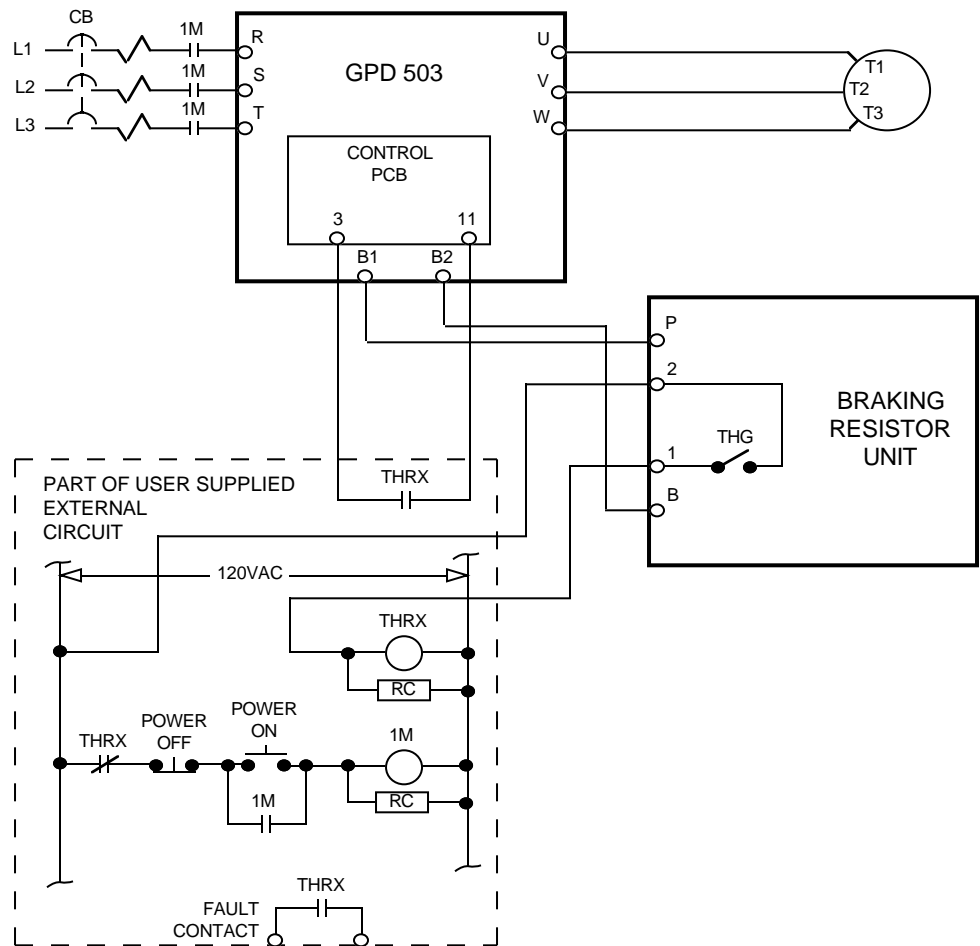

Figure A7-3. Wiring Braking Resistor Unit to Drive (230V 1-10HP(CT), 460V 1-20HP(CT), 575V 2-25HP(CT))

Braking Unit(s) and Braking Resistor Unit(s) Installation (for 230V 15HP(CT) and above, 460V 25HP(CT) and above, 575V 30HP(CT) and above)

IMPORTANT

Since the Braking Resistor Unit generates heat during dynamic braking operation, install it in a location away from other equipment which emits heat.

Select mounting locations for the Braking Unit(s) and Braking Resistor Unit(s) so that wiring between the drive and the (Master) Braking Unit, and between each Braking Unit and its associated Braking Resistor Unit, is less than 33 feet (10 m).

1. Mount the Braking Unit(s) and Braking Resistor Unit(s) on vertical surfaces. A Braking Unit requires a minimum 1.18 inch (30 mm) clearance on each side and a minimum 3.94 inch (100 mm) clearance top and bottom; a Braking Resistor Unit requires a minimum 1.97 inch (50 mm) clearance in back (i.e. use mounting spacers) and a minimum 7.87 inch (200 mm) clearance in front.
 2. Remove DB units' front covers to access their terminals.
 3. For 460V drives only: In each Braking Unit, set the PCB nominal line voltage jumper plug to the correct setting for the installation; this is factory set at the "460V" position.
 4. If multiple Braking Units are being installed, the unit closest to the drive should have the SLAVE/MASTER jumper on its PCB set to the "MASTER" position (factory setting); all others must have this jumper moved to the "SLAVE" position.
 5. If a single Braking Unit and Braking Resistor Unit are being installed, connect them to the drive and external control circuitry according to the chart below and Figure A7-4.
- If two or more Braking Units and Braking Resistor Units are being installed, connect them to the drive and to external circuitry according to the chart below and Figure A7-5.

UNIT	TERMINALS	LEAD SIZE (AWG)	LEAD TYPE	TERMINAL SCREWS
Braking Resistor Unit	B, P	12-10	600V ethylene propylene rubber insulated or equivalent	M5
	1, 2 *	18-14 *		M4
Braking Unit	P, Po, N, B	12-10	600V ethylene propylene rubber insulated, or equivalent	M4
	1, 2 *	18-14 *		

* Power leads for the Braking Resistor Unit generate high levels of electrical noise; these signal leads must be grouped separately.

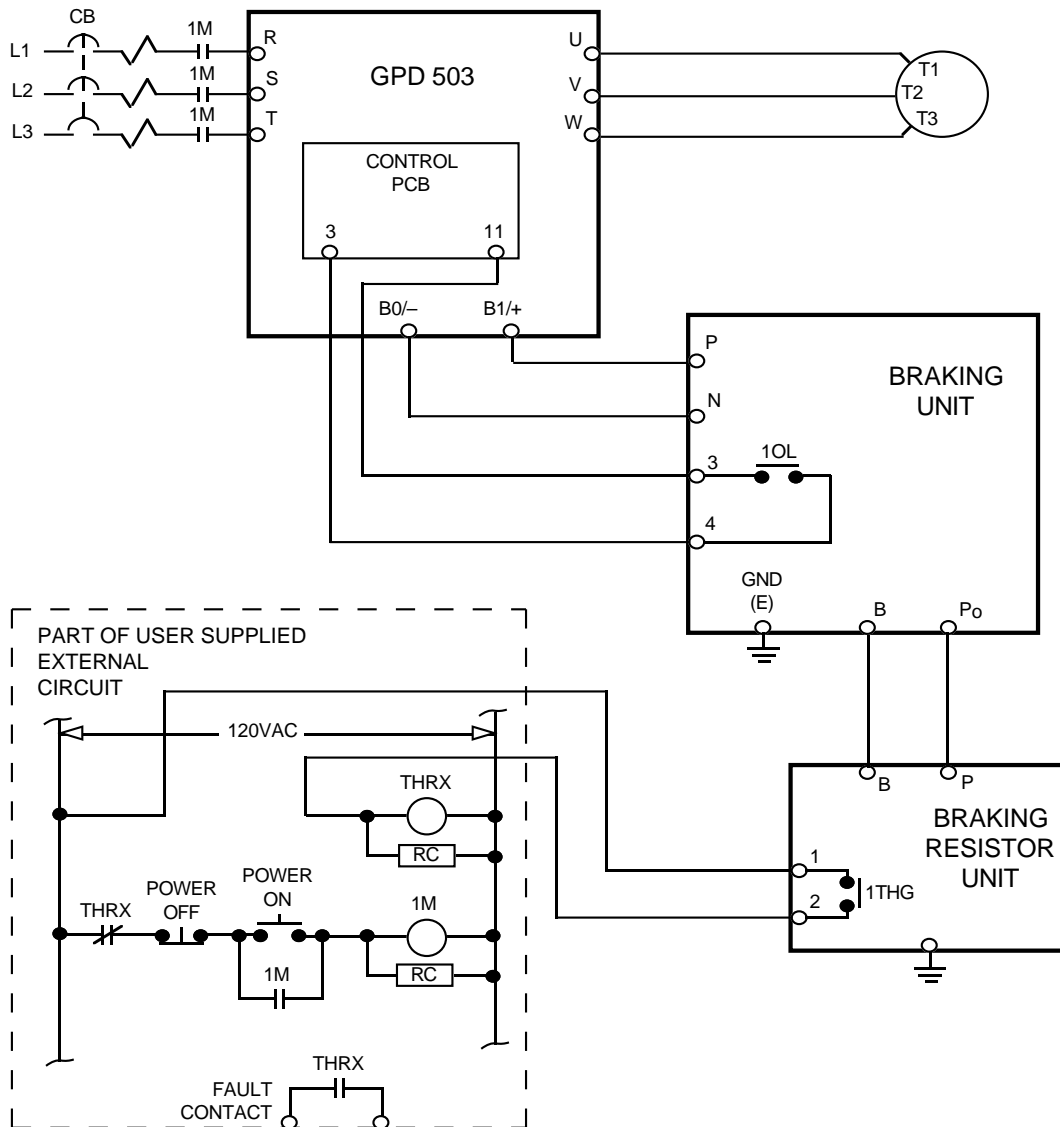

Figure A7-4. Wiring Single Braking Unit and Braking Resistor Unit to Drive (230V 15-30HP(CT), 460V 25-60HP(CT), 575V 30-50HP(CT))

6. The Braking Unit and Braking Resistor Unit **MUST BE GROUNDED**. Observe the following precautions:

- Use grounding leads conforming to your National Electrical Code.
- If the installation requires the Braking Resistor Unit to be used without its enclosure (with grounding terminal), ground it by attaching a ground lead at one of the mounting screws.
- Grounding resistance of the Braking Unit should be 100 ohms or less.

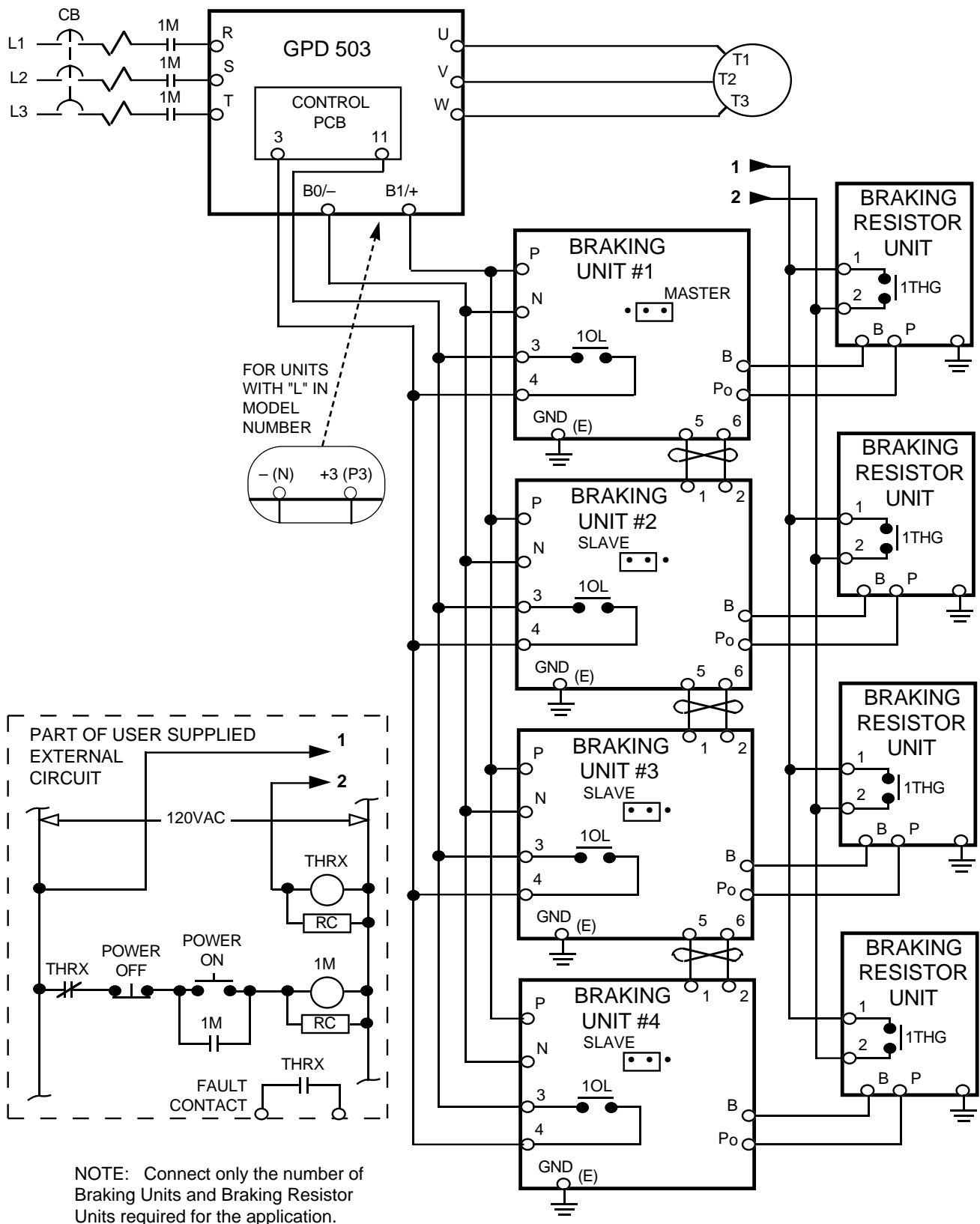

Figure A7-5. Wiring Multiple Braking Units and Braking Resistor Units to Drive (230V 40-100HP(CT), 460V 75-400HP(CT), 575V 60-200HP(CT))

8. **IMPORTANT:** After wiring, test insulation resistance of each Braking Unit/Braking Resistor Unit with a 900V megger as follows:

- a. Disconnect leads between the Braking Unit and the drive. If equipment with semiconductors is connected across terminals 1 & 2 of the Braking Unit, remove the wiring.
- b. Connect common leads (jumpers) across Braking Unit terminals N, P, Po, and B, and across 3 & 4, as shown in Figure A7-6.
- c. Measure the insulation resistance at points a, b, and c in Figure A7-6 with the megger.

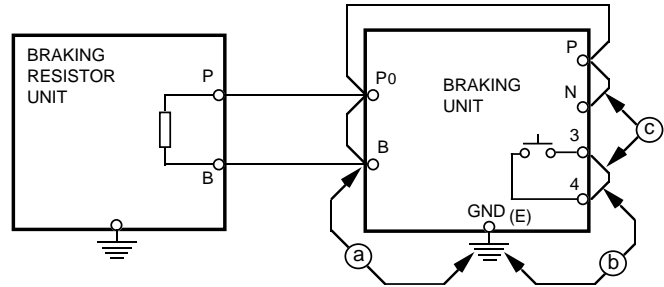

Figure A7-6. Megger Testing Set-up

ADJUSTMENTS

9. ALL drives: Program Sn-10 to XX1X, to disable stall prevention during decel.
10. Only with Heat Sink Mount Resistor: Program Sn-11 to XXX1, to enable overheat protection for the braking resistor.

OPERATION CHECK

11. During dynamic braking operation, verify that the "BRAKE" lamp inside the Braking Unit will be lit.
12. During dynamic braking operations, ensure that the required deceleration characteristic is obtained. If not, contact MagneTek for assistance.
13. Reinstall and secure covers on the DB units and the drive.

CAUTION

During normal operation, the Braking Unit and the Braking Resistor Unit must remain closed, since high voltage is applied to the dynamic braking circuit.

Please send information on the following:

DDM™ DriveDataManager

A program to create and edit configuration files for MagneTek AC drives.

A program to upload/download configuration files for high-speed programming, production change, or backup.

GPD 503 Programming Instruction Cards

A free set of pocket-size cards which provide the user a rapid reference for programming GPD 503 constants.

Allow one week for delivery.

GPD 503 Training

Descriptions and dates of training sessions on operating and applications of GPD 503 AC drives.

Additional Copies of GPD 503 Technical Manual

Information will be provided on how to order copies of TM 4231.

Name _____

Position/Title _____

Company _____

Address _____

City _____ State _____ ZIP _____

Telephone () _____

GPD 503 : Model No. _____

Application : _____

Purchased through (if known) : _____

Mail this form , or FAX (414) 782-3418

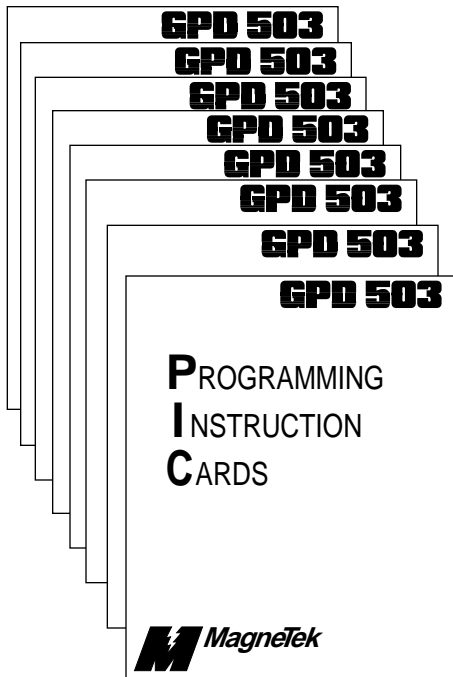

Free set of plastic coated pocket sized cards which provide to the user a rapid reference for programming GPD 503 constants. For your free set, complete and return this response sheet. Allow 1 week for delivery.

Name _____

Position / Title _____

Company _____

Address _____

City _____ State _____ ZIP _____

Telephone () _____ - _____

Drive Used On _____

Purchased From _____

GPD 503

Data subject to change without notice. GPD and DDM are trademarks of MagneTek, Inc.

MagneTek
Drives & Systems
16555 West Ryerson Road
New Berlin, WI 53151
(800) 541-0939, (414) 782-0200, FAX (414) 782-1283

