

Kinetix 6000 Power Rail

Catalog Numbers 2094-PRS1, 2094-PRS2, 2094-PRS3, 2094-PRS4, 2094-PRS5, 2094-PRS6, 2094-PRS7, 2094-PRS8, 2094-PR1, 2094-PR2, 2094-PR4, 2094-PR6, 2094-PR8

Topic	Page
About the Kinetix 6000 Power Rail	1
Important User Information	2
Catalog Number Explanation	3
Before You Begin	3
Install the Kinetix 6000 Power Rail	4
Product Dimensions	6
Additional Resources	8

About the Kinetix 6000 Power Rail

The Kinetix 6000 power rail provides power and control signals from the Bulletin 2094 integrated axis (IAM) converter module to adjacent axis (AM) inverter, shunt, and slot-filler modules. The Bulletin 2094 IAM and AM modules, and Kinetix 6000 shunt and slot-filler modules mount on the Kinetix 6000 power rail.

For detailed information on wiring, applying power, troubleshooting, and integration with ControlLogix, CompactLogix, and SoftLogix controller platforms, refer to [Additional Resources](#) on [page 8](#), for the appropriate Bulletin 2094 servo drive user manual.

Refer to the System Design for Control of Electrical Noise Reference Manual, publication [GMC-RM001](#), for greater detail on reducing electrical noise when installing your power rail.

Important User Information

Solid state equipment has operational characteristics differing from those of electromechanical equipment. Safety Guidelines for the Application, Installation and Maintenance of Solid State Controls (publication [SGI-1.1](#) available from your local Rockwell Automation sales office or online at <http://www.rockwellautomation.com/literature>) describes some important differences between solid state equipment and hard-wired electromechanical devices. Because of this difference, and also because of the wide variety of uses for solid state equipment, all persons responsible for applying this equipment must satisfy themselves that each intended application of this equipment is acceptable.

In no event will Rockwell Automation, Inc. be responsible or liable for indirect or consequential damages resulting from the use or application of this equipment.

The examples and diagrams in this manual are included solely for illustrative purposes. Because of the many variables and requirements associated with any particular installation, Rockwell Automation, Inc. cannot assume responsibility or liability for actual use based on the examples and diagrams.

No patent liability is assumed by Rockwell Automation, Inc. with respect to use of information, circuits, equipment, or software described in this manual.

Reproduction of the contents of this manual, in whole or in part, without written permission of Rockwell Automation, Inc., is prohibited.

Throughout this manual, when necessary, we use notes to make you aware of safety considerations.

	WARNING: Identifies information about practices or circumstances that can cause an explosion in a hazardous environment, which may lead to personal injury or death, property damage, or economic loss.
	ATTENTION: Identifies information about practices or circumstances that can lead to personal injury or death, property damage, or economic loss. Attentions help you identify a hazard, avoid a hazard and recognize the consequences.
	SHOCK HAZARD: Labels may be on or inside the equipment (for example, drive or motor) to alert people that dangerous voltage may be present.
	BURN HAZARD: Labels may be on or inside the equipment (for example, drive or motor) to alert people that surfaces may reach dangerous temperatures.
IMPORTANT	Identifies information that is critical for successful application and understanding of the product.

Catalog Number Explanation

This publication applies to the following Bulletin 2094 power rails.

Cat. No.	Description	Module Capacity ⁽¹⁾
2094-PRS1	Power rail (slim), 230V or 460V drive systems	1 IAM module and no additional modules
2094-PRS2		1 IAM module and up to 1 additional module
2094-PRS3		1 IAM module and up to 2 additional modules
2094-PRS4		1 IAM module and up to 3 additional modules
2094-PRS5		1 IAM module and up to 4 additional modules
2094-PRS6		1 IAM module and up to 5 additional modules
2094-PRS7		1 IAM module and up to 6 additional modules
2094-PRS8		1 IAM module and up to 7 additional modules
2094-PR1	Power rail, 230V or 460V drive systems	1 IAM module and no additional modules
2094-PR2		1 IAM module and up to 1 additional module
2094-PR4		1 IAM module and up to 3 additional modules
2094-PR6		1 IAM module and up to 5 additional modules
2094-PR8		1 IAM module and up to 7 additional modules

- (1) Module capacity is reduced when using double-wide IAM and AM modules. The 2094-AC32-M05-x, 2094-BC04-M03-x, and 2094-BC07-M05-x double-wide IAM modules each require one converter slot and two inverter slots. All other (single-wide) IAM modules require one converter slot and one inverter slot. The 2094-BM03-x and 2094-BM05-x double-wide AM modules each require two inverter slots. All other (single-wide) AM modules require one inverter slot. Refer to the Kinetix Motion Control Selection Guide, publication [GMC-SG001](#), for more information on selecting Bulletin 2094 power rails.

Before You Begin

Remove all packing material, wedges, and braces from within and around the components. After unpacking, check the item nameplate catalog number against the purchase order.

Parts List

Drive Component	Ships With
Power Rail	<ul style="list-style-type: none"> ● One braided 100 mm (3.9 in.) ground strap ● Protective covers (one covering each of the power rail connectors) ● These installation instructions, publication 2094-IN003

IMPORTANT To improve the bond between the power rail and subpanel, construct your subpanel out of zinc plated (paint free) steel.

Install the Kinetix 6000 Power Rail

This procedure assumes that you have prepared your panel and understand how to bond your system. For installation instructions regarding equipment and accessories not included here, refer to the instructions that came with those products.



SHOCK HAZARD: To avoid hazard of electrical shock, perform all mounting and wiring of the Bulletin 2094 power rail and drive modules prior to applying power. Once power is applied, connector terminals may have voltage present even when not in use.



ATTENTION: Plan the installation of your system so that you can perform all cutting, drilling, tapping, and welding with the system removed from the enclosure. Because the system is of open type construction, be careful to keep any metal debris from falling into it. Metal debris or other foreign matter can become lodged in the circuitry, which can result in damage to components.

Using Bulletin 2094 Mounting Brackets

Bulletin 2094 mounting brackets can be used to mount the power rail over the AC line filter. Refer to the 2094 Mounting Brackets Installation Instructions, publication [2094-IN008](#), when using mounting brackets with your Kinetix 6000 drive system.

Mount the Kinetix 6000 Power Rail

The Kinetix 6000 power rail comes in lengths to support one IAM module, and up to seven additional AM modules or up to six additional AM modules and one shunt module. The connector pins for each slot are covered by a protective cover. The cover is designed to protect the pins from damage and make sure that no foreign objects lodge between the pins during installation.



ATTENTION: To avoid damage to power-rail connector pins during installation, do not remove the protective covers until the module for each slot is ready for mounting.

Follow these steps to mount your 2094-PRSx or 2094-PRx power rail.

1. Lay out the position for your power rail in the enclosure.

Refer to your servo drive user manual for panel layout recommendations. Mounting hole dimensions for the power rail are shown in the figures on [page 6](#).

2. Attach the power rail to the cabinet.

The recommended mounting hardware is M6 metric (1/4x20) bolts. Refer to the System Design for Control of Electrical Noise Reference Manual, publication [GMC-RM001](#), for HF bonding techniques.

IMPORTANT To improve the bond between the power rail and subpanel, construct your subpanel out of zinc plated (paint-free) steel.

3. Tighten all mounting fasteners.

Apply 5.08 N•m (45.0 lb•in) torque.

4. Attach the braided grounding strap from the grounding stud to the bonded cabinet ground.

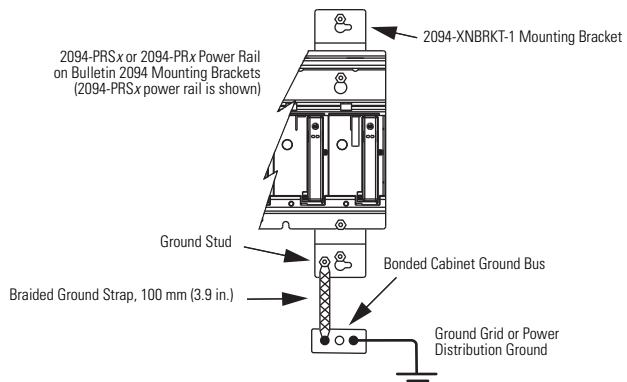
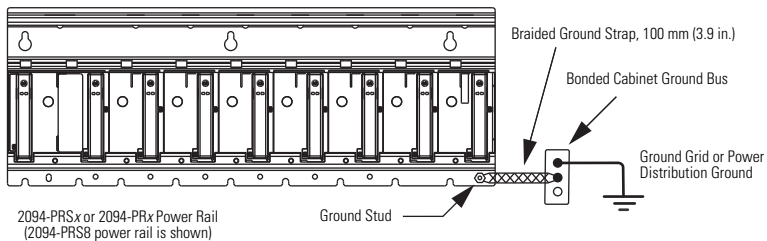

Product Dimensions

These are the mounting dimensions for the Bulletin 2094 power rail.

2094-PRS1 (Slim) Power Rail

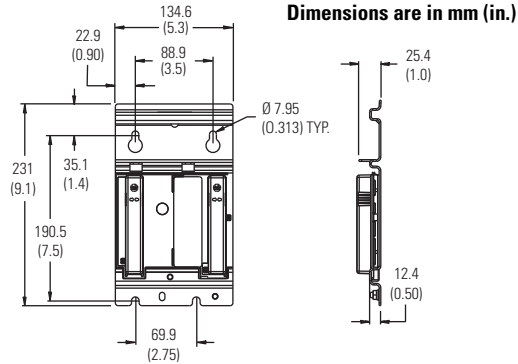

2094-PRS2, 2094-PRS3, 2094-PRS4, 2094-PRS5, 2094-PRS6, 2094-PRS7, and 2094-PRS8 (Slim) Power Rails

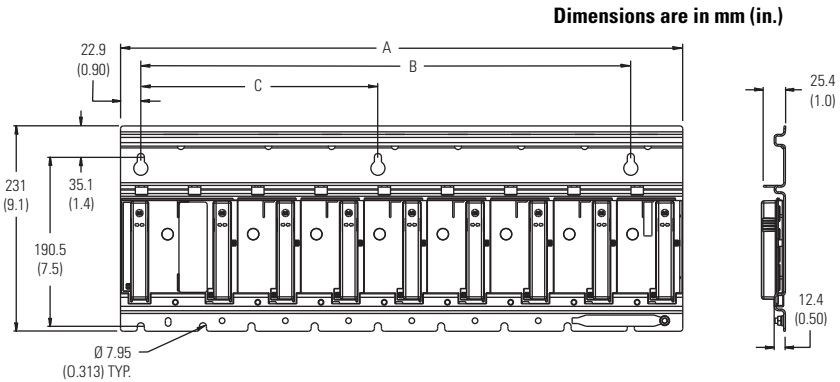

Cat. No.	Description	Dimension A mm (in.)	Dimension B mm (in.)	Dimension C mm (in.)
2094-PRS2	2-axis power rail	205.7 (8.10)	124.5 (4.90)	N/A
2094-PRS3	3-axis power rail	276.9 (10.90)	195.6 (7.70)	N/A
2094-PRS4	4-axis power rail	348.0 (13.70)	266.7 (10.50)	N/A
2094-PRS5	5-axis power rail	419.1 (16.50)	337.8 (13.30)	195.6 (7.70)
2094-PRS6	6-axis power rail	490.2 (19.30)	408.9 (16.10)	195.6 (7.70)
2094-PRS7	7-axis power rail	561.3 (22.10)	480.1 (18.90)	266.7 (10.50)
2094-PRS8	8-axis power rail	632.5 (24.90)	551.2 (21.70)	266.7 (10.50)

2094-PR1, 2094-PR2, 2094-PR4, 2094-PR6, and 2094-PR8 Power Rails

Dimensions are in mm (in.)

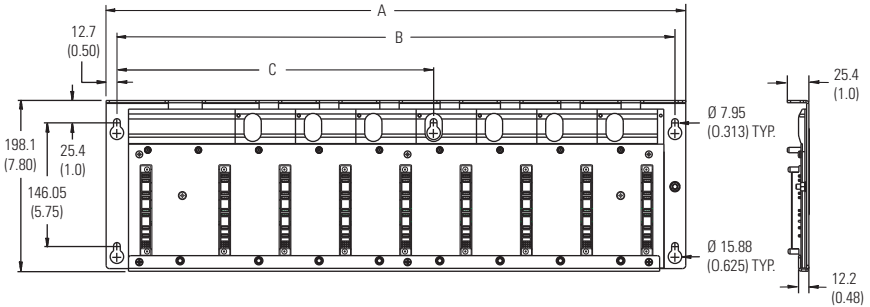

Cat. No.	Description	Dimension A mm (in.)	Dimension B mm (in.)	Dimension C mm (in.)
2094-PR1	1-axis power rail	185.42 (7.30)	160.02 (6.30)	N/A
2094-PR2	2-axis power rail	256.54 (10.10)	231.14 (9.10)	N/A
2094-PR4	4-axis power rail	398.78 (15.70)	373.38 (14.70)	N/A
2094-PR6	6-axis power rail	541.02 (21.30)	515.62 (20.30)	302.26 (11.90)
2094-PR8	8-axis power rail	683.26 (26.90)	657.86 (25.90)	373.38 (14.70)

Additional Resources

These documents contain additional information concerning related Rockwell Automation products.

Resource	Description
Kinetix 6000 Multi-axis Servo Drive User Manual, publication 2094-UM001	Information on installing, configuring, startup, troubleshooting, and wiring diagrams for your Bulletin 2094 servo drive system.
Kinetix 6200 and Kinetix 6500 Multi-axis Servo Drive User Manual, publication 2094-UM002	
Kinetix 6000 Shunt Module Installation Instructions, publication 2094-IN004	Information on the installation of your Bulletin 2094 shunt module.
Kinetix 6000 Slot-filler Module Installation Instructions, publication 2094-IN006	Information on the installation of your Bulletin 2094 slot-filler module.
2094 Mounting Bracket Installation Instructions, publication 2094-IN008	Information on the installation of Bulletin 2094 mounting brackets.
System Design for Control of Electrical Noise Reference Manual, publication GMC-RM001	Information, examples, and techniques designed to minimize system failures caused by electrical noise.
EMC Noise Management DVD, publication GMC-SP001	
Kinetix Motion Control Selection Guide, publication GMC-SG001	Specifications, motor/servo-drive system combinations, and accessories for Kinetix Motion Control products.
Rockwell Automation Configuration and Selection Tools, website http://www.ab.com/e-tools	Online product selection and system configuration tools, including AutoCAD (DXF) drawings.
Rockwell Automation Product Certification, website http://www.rockwellautomation.com/products/certification	For declarations of conformity (DoC) currently available from Rockwell Automation.
National Electrical Code, published by the National Fire Protection Association of Boston, MA	An article on wire sizes and types for grounding electrical equipment.
Rockwell Automation Industrial Automation Glossary, publication AG-7.1	A glossary of industrial automation terms and abbreviations.

You can view or download publications at <http://www.rockwellautomation.com/literature>. To order paper copies of technical documentation, contact your local Rockwell Automation distributor or sales representative.

Allen-Bradley, CompactLogix, ControlLogix, Kinetix, Rockwell Software, Rockwell Automation, Rockwell Software, and SoftLogix are trademarks of Rockwell Automation, Inc.

Trademarks not belonging to Rockwell Automation are property of their respective companies.

Rockwell Otomasyon Ticaret A.Ş., Kar Plaza İş Merkezi E Blok Kat:6 34752 İçerenköy, İstanbul, Tel: +90 (216) 5698400

www.rockwellautomation.com

Power, Control and Information Solutions Headquarters

Americas: Rockwell Automation, 1201 South Second Street, Milwaukee, WI 53204-2496 USA, Tel: (1) 414.382.2000, Fax: (1) 414.382.4444
Europe/Middle East/Africa: Rockwell Automation NV, Pegasus Park, De Kleetlaan 12a, 1831 Diegem, Belgium, Tel: (32) 2 663 0600, Fax: (32) 2 663 0640
Asia Pacific: Rockwell Automation, Level 14, Core F, Cyberport 3, 100 Cyberport Road, Hong Kong, Tel: (852) 2887 4788, Fax: (852) 2508 1846

Publication 2094-IN003D-EN-P - November 2010

PN-93743

Supersedes Publication 2094-IN003C-EN-P - June 2008

Copyright © 2010 Rockwell Automation, Inc. All rights reserved. Printed in the U.S.A.