

Module Mounting Unit IEMMU11, IEMMU12, IEMMU21, IEMMU22





The IEMMU11, IEMMU12, IEMMU21, and IEMMU22 units are module mounting units used to house Harmony rack modules in system cabinets of the Symphony™ Enterprise Management and Control System. The mounting units are available with a front-mount or rear-mount card chassis and are available with or without primary power distribution.

NOTE: The IEMMU11, IEMMU12, IEMMU21, and IEMMU22 Module Mounting Units can replace existing IEMMU01 and IEMMU02 Module Mounting Units.

This instruction explains how to install and maintain the module mounting unit.



List of Effective Pages

Total number of pages in this instruction is 40, consisting of the following:

Page No.	Change Date
Preface	Original
List of Effective Pages	Original
iii through viii	Original
1-1 through 1-8	Original
2-1 through 2-4	Original
3-1 through 3-11	Original
4-1 through 4-2	Original
5-1 through 5-5	Original
Index-1 through Index-2	Original

NOTE: Changed text or tables are indicated by a vertical bar adjacent to the changed area. Changed figures are indicated by a vertical bar next to the figure caption. The date appears beside the page number.

Table of Contents



Section 1 Introduction	1-1
Overview	1-1
IEMMU11 and IEMMU12 Module Mounting Units	1-1
IEMMU21 and IEMMU22 Module Mounting Units	1-2
IEMMU01 and IEMMU02 Replacement	1-2
IEMMU01 and IEMMU02 Connection	1-3
Intended User	1-3
Features	1-3
Instruction Content	1-4
How to Use this Instruction	1-4
Glossary of Terms and Abbreviations	1-5
Document Conventions	1-5
Reference Documents	1-5
Nomenclature	1-5
Related Hardware	1-6
Specifications	1-6
Section 2 Description and Operation	2-1
Introduction	2-1
Input Power and Power Distribution	2-1
Power Module Input Power	2-1
Output Power	2-2
I/O Expander Bus	2-3
Controlway	2-3
Overcurrent Protection	2-4
Section 3 Installation	3-1
Introduction	3-1
Tools	3-1
Controlway Segmenting	3-1
Installation	3-2
Transition Board Installation	3-4
Processor Bus Adapter Brackets Installation	3-5
Backplane I/O Connectors	3-6
Section 4 Maintenance	4-1
Introduction	4-1
Preventive Maintenance Schedule	4-1
Equipment and Tools Required	4-1



Table of Contents (continued)

Section 5 Repair and Replacement	5-1
Introduction	5-1
Parts List.....	5-1
Tools	5-2
Backplane Assembly Replacement	5-3
Power Module Removal	5-5

List of Figures

No.	Title	Page
2-1.	MMU Backplane Connector Locations (Module Side)	2-2
3-1.	Controlway Segmenting	3-2
3-2.	Module Mounting Unit Connections	3-4
3-3.	Processor Bus Adapter Brackets Installation	3-7
3-4.	P25 - P35 Pin Location	3-9
3-5.	P1 Connector Pin Location	3-10
3-6.	P2 Connector Pin Location	3-11

List of Tables

No.	Title	Page
1-1.	Glossary of Terms and Abbreviations	1-5
1-2.	Reference Documents	1-5
1-3.	Nomenclature	1-6
1-4.	Related Hardware	1-6
1-5.	Specifications	1-6
1-6.	Amperage Ratings	1-8
2-1.	DC Power Connectors	2-3
3-1.	Controlway Jumper Settings	3-2
3-2.	MMU Cables.....	3-3
3-3.	Input Power Signals.....	3-8
3-4.	Controlway and Regulated Power Supply Signals	3-8
3-5.	Output Signals	3-8
3-6.	P1 Connector	3-9
3-7.	P2 Connector (I/O Expander Bus)	3-10

List of Tables (continued)

<i>No.</i>	<i>Title</i>	<i>Pg.</i>
4-1.	Preventive Maintenance Schedule	4-2
5-1.	Cables	5-1
5-2.	Fasteners	5-1
5-3.	Miscellaneous Parts	5-2



Safety Summary

**GENERAL
WARNINGS**

Equipment Environment

All components, whether in transportation, operation or storage, must be in a noncorrosive environment.

Electrical Shock Hazard During Maintenance

Disconnect power or take precautions to insure that contact with energized parts is avoided when servicing.

**SPECIFIC
WARNINGS**

Disconnect power before installing the processor bus adapter mounting bracket on the module mounting unit backplane. Failure to do so will result in contact with cabinet areas that could cause severe or fatal shock. (p. 3-5)

There are exposed AC and DC connections inside the cabinet. These exposed electrical connections present a shock hazard that can cause injury or death. (p. 5-3)

Handle the module by surfaces other than the heat sink. The heat sink may be hot and may cause severe burns. (p. 5-5)

Allow 30 seconds for the line filter capacitors to discharge before handling the power module. Failure to do so could result in severe or fatal shock. (p. 5-5)

**SPECIFIC
CAUTIONS**

Installation of more than two power modules will result in loss of regulation and voids the warranty. Equipment damage will result. (p. 3-3)

Support Services



Elsag Bailey will provide assistance in the operation and repair of its products. Requests for sales or application services should be made to your nearest sales or service office. Elsag Bailey can also provide installation, repair and maintenance contract services.

When ordering parts, use nomenclature or part numbers and part descriptions from equipment manuals. Parts without a description must be ordered from the nearest sales or service office. Recommended spare parts lists, including prices are available through the nearest sales or service office.

Elsag Bailey has modern training facilities available for training your personnel. On-site training is also available. Contact your nearest Elsag Bailey sales office for specific information and scheduling.

Additional copies of this instruction, or other instructions, can be obtained from the nearest Elsag Bailey sales office at a reasonable charge.



Trademarks and Registrations

Registrations and trademarks used in this document include:

TM Symphony

Trademark of Eltag Bailey Process Automation



The IEMMU11, IEMMU12, IEMMU21, and IEMMU22 units are module mounting units used to house Harmony rack modules in system cabinets of the Symphony™ Enterprise Management and Control System. The mounting units are available with a front-mount or rear-mount card chassis and are available with or without primary power distribution.

NOTE: The IEMMU11, IEMMU12, IEMMU21, and IEMMU22 Module Mounting Units can replace existing IEMMU01 and IEMMU02 Module Mounting Units.

This instruction explains how to install and maintain the module mounting unit.



List of Effective Pages

Total number of pages in this instruction is 40, consisting of the following:

Page No.	Change Date
Preface	Original
List of Effective Pages	Original
iii through viii	Original
1-1 through 1-8	Original
2-1 through 2-4	Original
3-1 through 3-11	Original
4-1 through 4-2	Original
5-1 through 5-5	Original
Index-1 through Index-2	Original

NOTE: Changed text or tables are indicated by a vertical bar adjacent to the changed area. Changed figures are indicated by a vertical bar next to the figure caption. The date appears beside the page number.

Table of Contents



Section 1 Introduction	1-1
Overview	1-1
IEMMU11 and IEMMU12 Module Mounting Units	1-1
IEMMU21 and IEMMU22 Module Mounting Units	1-2
IEMMU01 and IEMMU02 Replacement	1-2
IEMMU01 and IEMMU02 Connection	1-3
Intended User	1-3
Features	1-3
Instruction Content	1-4
How to Use this Instruction	1-4
Glossary of Terms and Abbreviations	1-5
Document Conventions	1-5
Reference Documents	1-5
Nomenclature	1-5
Related Hardware	1-6
Specifications	1-6
Section 2 Description and Operation	2-1
Introduction	2-1
Input Power and Power Distribution	2-1
Power Module Input Power	2-1
Output Power	2-2
I/O Expander Bus	2-3
Controlway	2-3
Overcurrent Protection	2-4
Section 3 Installation	3-1
Introduction	3-1
Tools	3-1
Controlway Segmenting	3-1
Installation	3-2
Transition Board Installation	3-4
Processor Bus Adapter Brackets Installation	3-5
Backplane I/O Connectors	3-6
Section 4 Maintenance	4-1
Introduction	4-1
Preventive Maintenance Schedule	4-1
Equipment and Tools Required	4-1



Table of Contents (continued)

Section 5 Repair and Replacement	5-1
Introduction	5-1
Parts List.....	5-1
Tools	5-2
Backplane Assembly Replacement	5-3
Power Module Removal	5-5

List of Figures

No.	Title	Page
2-1.	MMU Backplane Connector Locations (Module Side)	2-2
3-1.	Controlway Segmenting	3-2
3-2.	Module Mounting Unit Connections	3-4
3-3.	Processor Bus Adapter Brackets Installation	3-7
3-4.	P25 - P35 Pin Location	3-9
3-5.	P1 Connector Pin Location	3-10
3-6.	P2 Connector Pin Location	3-11

List of Tables

No.	Title	Page
1-1.	Glossary of Terms and Abbreviations	1-5
1-2.	Reference Documents	1-5
1-3.	Nomenclature	1-6
1-4.	Related Hardware	1-6
1-5.	Specifications	1-6
1-6.	Amperage Ratings	1-8
2-1.	DC Power Connectors	2-3
3-1.	Controlway Jumper Settings	3-2
3-2.	MMU Cables.....	3-3
3-3.	Input Power Signals.....	3-8
3-4.	Controlway and Regulated Power Supply Signals	3-8
3-5.	Output Signals	3-8
3-6.	P1 Connector	3-9
3-7.	P2 Connector (I/O Expander Bus)	3-10

List of Tables (continued)

<i>No.</i>	<i>Title</i>	<i>Pg.</i>
4-1.	Preventive Maintenance Schedule	4-2
5-1.	Cables	5-1
5-2.	Fasteners	5-1
5-3.	Miscellaneous Parts	5-2



Safety Summary

**GENERAL
WARNINGS**

Equipment Environment

All components, whether in transportation, operation or storage, must be in a noncorrosive environment.

Electrical Shock Hazard During Maintenance

Disconnect power or take precautions to insure that contact with energized parts is avoided when servicing.

**SPECIFIC
WARNINGS**

Disconnect power before installing the processor bus adapter mounting bracket on the module mounting unit backplane. Failure to do so will result in contact with cabinet areas that could cause severe or fatal shock. (p. 3-5)

There are exposed AC and DC connections inside the cabinet. These exposed electrical connections present a shock hazard that can cause injury or death. (p. 5-3)

Handle the module by surfaces other than the heat sink. The heat sink may be hot and may cause severe burns. (p. 5-5)

Allow 30 seconds for the line filter capacitors to discharge before handling the power module. Failure to do so could result in severe or fatal shock. (p. 5-5)

**SPECIFIC
CAUTIONS**

Installation of more than two power modules will result in loss of regulation and voids the warranty. Equipment damage will result. (p. 3-3)

Support Services



Elsag Bailey will provide assistance in the operation and repair of its products. Requests for sales or application services should be made to your nearest sales or service office. Elsag Bailey can also provide installation, repair and maintenance contract services.

When ordering parts, use nomenclature or part numbers and part descriptions from equipment manuals. Parts without a description must be ordered from the nearest sales or service office. Recommended spare parts lists, including prices are available through the nearest sales or service office.

Elsag Bailey has modern training facilities available for training your personnel. On-site training is also available. Contact your nearest Elsag Bailey sales office for specific information and scheduling.

Additional copies of this instruction, or other instructions, can be obtained from the nearest Elsag Bailey sales office at a reasonable charge.



Trademarks and Registrations

Registrations and trademarks used in this document include:

TM Symphony

Trademark of Eltag Bailey Process Automation



The IEMMU11, IEMMU12, IEMMU21, and IEMMU22 units are module mounting units used to house Harmony rack modules in system cabinets of the Symphony™ Enterprise Management and Control System. The mounting units are available with a front-mount or rear-mount card chassis and are available with or without primary power distribution.

NOTE: The IEMMU11, IEMMU12, IEMMU21, and IEMMU22 Module Mounting Units can replace existing IEMMU01 and IEMMU02 Module Mounting Units.

This instruction explains how to install and maintain the module mounting unit.



List of Effective Pages

Total number of pages in this instruction is 40, consisting of the following:

Page No.	Change Date
Preface	Original
List of Effective Pages	Original
iii through viii	Original
1-1 through 1-8	Original
2-1 through 2-4	Original
3-1 through 3-11	Original
4-1 through 4-2	Original
5-1 through 5-5	Original
Index-1 through Index-2	Original

NOTE: Changed text or tables are indicated by a vertical bar adjacent to the changed area. Changed figures are indicated by a vertical bar next to the figure caption. The date appears beside the page number.

Table of Contents



Section 1 Introduction	1-1
Overview	1-1
IEMMU11 and IEMMU12 Module Mounting Units	1-1
IEMMU21 and IEMMU22 Module Mounting Units	1-2
IEMMU01 and IEMMU02 Replacement	1-2
IEMMU01 and IEMMU02 Connection	1-3
Intended User	1-3
Features	1-3
Instruction Content.....	1-4
How to Use this Instruction	1-4
Glossary of Terms and Abbreviations	1-5
Document Conventions	1-5
Reference Documents	1-5
Nomenclature	1-5
Related Hardware	1-6
Specifications.....	1-6
Section 2 Description and Operation	2-1
Introduction.....	2-1
Input Power and Power Distribution.....	2-1
Power Module Input Power	2-1
Output Power.....	2-2
I/O Expander Bus	2-3
Controlway	2-3
Overcurrent Protection.....	2-4
Section 3 Installation	3-1
Introduction.....	3-1
Tools.....	3-1
Controlway Segmenting.....	3-1
Installation	3-2
Transition Board Installation	3-4
Processor Bus Adapter Brackets Installation	3-5
Backplane I/O Connectors	3-6
Section 4 Maintenance	4-1
Introduction.....	4-1
Preventive Maintenance Schedule	4-1
Equipment and Tools Required	4-1



Table of Contents (continued)

Section 5 Repair and Replacement	5-1
Introduction	5-1
Parts List.....	5-1
Tools	5-2
Backplane Assembly Replacement	5-3
Power Module Removal	5-5

List of Figures

No.	Title	Page
2-1.	MMU Backplane Connector Locations (Module Side)	2-2
3-1.	Controlway Segmenting	3-2
3-2.	Module Mounting Unit Connections	3-4
3-3.	Processor Bus Adapter Brackets Installation	3-7
3-4.	P25 - P35 Pin Location	3-9
3-5.	P1 Connector Pin Location	3-10
3-6.	P2 Connector Pin Location	3-11

List of Tables

No.	Title	Page
1-1.	Glossary of Terms and Abbreviations	1-5
1-2.	Reference Documents	1-5
1-3.	Nomenclature	1-6
1-4.	Related Hardware	1-6
1-5.	Specifications	1-6
1-6.	Amperage Ratings	1-8
2-1.	DC Power Connectors	2-3
3-1.	Controlway Jumper Settings	3-2
3-2.	MMU Cables.....	3-3
3-3.	Input Power Signals.....	3-8
3-4.	Controlway and Regulated Power Supply Signals	3-8
3-5.	Output Signals	3-8
3-6.	P1 Connector	3-9
3-7.	P2 Connector (I/O Expander Bus)	3-10

List of Tables (continued)

<i>No.</i>	<i>Title</i>	<i>Pg.</i>
4-1.	Preventive Maintenance Schedule	4-2
5-1.	Cables	5-1
5-2.	Fasteners	5-1
5-3.	Miscellaneous Parts	5-2



Safety Summary

**GENERAL
WARNINGS**

Equipment Environment

All components, whether in transportation, operation or storage, must be in a noncorrosive environment.

Electrical Shock Hazard During Maintenance

Disconnect power or take precautions to insure that contact with energized parts is avoided when servicing.

**SPECIFIC
WARNINGS**

Disconnect power before installing the processor bus adapter mounting bracket on the module mounting unit backplane. Failure to do so will result in contact with cabinet areas that could cause severe or fatal shock. (p. 3-5)

There are exposed AC and DC connections inside the cabinet. These exposed electrical connections present a shock hazard that can cause injury or death. (p. 5-3)

Handle the module by surfaces other than the heat sink. The heat sink may be hot and may cause severe burns. (p. 5-5)

Allow 30 seconds for the line filter capacitors to discharge before handling the power module. Failure to do so could result in severe or fatal shock. (p. 5-5)

**SPECIFIC
CAUTIONS**

Installation of more than two power modules will result in loss of regulation and voids the warranty. Equipment damage will result. (p. 3-3)

Support Services



Elsag Bailey will provide assistance in the operation and repair of its products. Requests for sales or application services should be made to your nearest sales or service office. Elsag Bailey can also provide installation, repair and maintenance contract services.

When ordering parts, use nomenclature or part numbers and part descriptions from equipment manuals. Parts without a description must be ordered from the nearest sales or service office. Recommended spare parts lists, including prices are available through the nearest sales or service office.

Elsag Bailey has modern training facilities available for training your personnel. On-site training is also available. Contact your nearest Elsag Bailey sales office for specific information and scheduling.

Additional copies of this instruction, or other instructions, can be obtained from the nearest Elsag Bailey sales office at a reasonable charge.



Trademarks and Registrations

Registrations and trademarks used in this document include:

TM Symphony

Trademark of Eltag Bailey Process Automation



The IEMMU11, IEMMU12, IEMMU21, and IEMMU22 units are module mounting units used to house Harmony rack modules in system cabinets of the Symphony™ Enterprise Management and Control System. The mounting units are available with a front-mount or rear-mount card chassis and are available with or without primary power distribution.

NOTE: The IEMMU11, IEMMU12, IEMMU21, and IEMMU22 Module Mounting Units can replace existing IEMMU01 and IEMMU02 Module Mounting Units.

This instruction explains how to install and maintain the module mounting unit.



List of Effective Pages

Total number of pages in this instruction is 40, consisting of the following:

Page No.	Change Date
Preface	Original
List of Effective Pages	Original
iii through viii	Original
1-1 through 1-8	Original
2-1 through 2-4	Original
3-1 through 3-11	Original
4-1 through 4-2	Original
5-1 through 5-5	Original
Index-1 through Index-2	Original

NOTE: Changed text or tables are indicated by a vertical bar adjacent to the changed area. Changed figures are indicated by a vertical bar next to the figure caption. The date appears beside the page number.

Table of Contents



Section 1 Introduction	1-1
Overview	1-1
IEMMU11 and IEMMU12 Module Mounting Units	1-1
IEMMU21 and IEMMU22 Module Mounting Units	1-2
IEMMU01 and IEMMU02 Replacement	1-2
IEMMU01 and IEMMU02 Connection	1-3
Intended User	1-3
Features	1-3
Instruction Content	1-4
How to Use this Instruction	1-4
Glossary of Terms and Abbreviations	1-5
Document Conventions	1-5
Reference Documents	1-5
Nomenclature	1-5
Related Hardware	1-6
Specifications	1-6
Section 2 Description and Operation	2-1
Introduction	2-1
Input Power and Power Distribution	2-1
Power Module Input Power	2-1
Output Power	2-2
I/O Expander Bus	2-3
Controlway	2-3
Overcurrent Protection	2-4
Section 3 Installation	3-1
Introduction	3-1
Tools	3-1
Controlway Segmenting	3-1
Installation	3-2
Transition Board Installation	3-4
Processor Bus Adapter Brackets Installation	3-5
Backplane I/O Connectors	3-6
Section 4 Maintenance	4-1
Introduction	4-1
Preventive Maintenance Schedule	4-1
Equipment and Tools Required	4-1



Table of Contents (continued)

Section 5 Repair and Replacement	5-1
Introduction	5-1
Parts List.....	5-1
Tools	5-2
Backplane Assembly Replacement	5-3
Power Module Removal	5-5

List of Figures

No.	Title	Page
2-1.	MMU Backplane Connector Locations (Module Side)	2-2
3-1.	Controlway Segmenting	3-2
3-2.	Module Mounting Unit Connections	3-4
3-3.	Processor Bus Adapter Brackets Installation	3-7
3-4.	P25 - P35 Pin Location	3-9
3-5.	P1 Connector Pin Location	3-10
3-6.	P2 Connector Pin Location	3-11

List of Tables

No.	Title	Page
1-1.	Glossary of Terms and Abbreviations	1-5
1-2.	Reference Documents	1-5
1-3.	Nomenclature	1-6
1-4.	Related Hardware	1-6
1-5.	Specifications	1-6
1-6.	Amperage Ratings	1-8
2-1.	DC Power Connectors	2-3
3-1.	Controlway Jumper Settings	3-2
3-2.	MMU Cables.....	3-3
3-3.	Input Power Signals.....	3-8
3-4.	Controlway and Regulated Power Supply Signals	3-8
3-5.	Output Signals	3-8
3-6.	P1 Connector	3-9
3-7.	P2 Connector (I/O Expander Bus)	3-10

List of Tables (continued)

<i>No.</i>	<i>Title</i>	<i>Pg.</i>
4-1.	Preventive Maintenance Schedule	4-2
5-1.	Cables	5-1
5-2.	Fasteners	5-1
5-3.	Miscellaneous Parts	5-2



Safety Summary

**GENERAL
WARNINGS**

Equipment Environment

All components, whether in transportation, operation or storage, must be in a noncorrosive environment.

Electrical Shock Hazard During Maintenance

Disconnect power or take precautions to insure that contact with energized parts is avoided when servicing.

**SPECIFIC
WARNINGS**

Disconnect power before installing the processor bus adapter mounting bracket on the module mounting unit backplane. Failure to do so will result in contact with cabinet areas that could cause severe or fatal shock. (p. 3-5)

There are exposed AC and DC connections inside the cabinet. These exposed electrical connections present a shock hazard that can cause injury or death. (p. 5-3)

Handle the module by surfaces other than the heat sink. The heat sink may be hot and may cause severe burns. (p. 5-5)

Allow 30 seconds for the line filter capacitors to discharge before handling the power module. Failure to do so could result in severe or fatal shock. (p. 5-5)

**SPECIFIC
CAUTIONS**

Installation of more than two power modules will result in loss of regulation and voids the warranty. Equipment damage will result. (p. 3-3)

Support Services



Elsag Bailey will provide assistance in the operation and repair of its products. Requests for sales or application services should be made to your nearest sales or service office. Elsag Bailey can also provide installation, repair and maintenance contract services.

When ordering parts, use nomenclature or part numbers and part descriptions from equipment manuals. Parts without a description must be ordered from the nearest sales or service office. Recommended spare parts lists, including prices are available through the nearest sales or service office.

Elsag Bailey has modern training facilities available for training your personnel. On-site training is also available. Contact your nearest Elsag Bailey sales office for specific information and scheduling.

Additional copies of this instruction, or other instructions, can be obtained from the nearest Elsag Bailey sales office at a reasonable charge.



Trademarks and Registrations

Registrations and trademarks used in this document include:

TM Symphony

Trademark of Eltag Bailey Process Automation



The IEMMU11, IEMMU12, IEMMU21, and IEMMU22 units are module mounting units used to house Harmony rack modules in system cabinets of the Symphony™ Enterprise Management and Control System. The mounting units are available with a front-mount or rear-mount card chassis and are available with or without primary power distribution.

NOTE: The IEMMU11, IEMMU12, IEMMU21, and IEMMU22 Module Mounting Units can replace existing IEMMU01 and IEMMU02 Module Mounting Units.

This instruction explains how to install and maintain the module mounting unit.



List of Effective Pages

Total number of pages in this instruction is 40, consisting of the following:

Page No.	Change Date
Preface	Original
List of Effective Pages	Original
iii through viii	Original
1-1 through 1-8	Original
2-1 through 2-4	Original
3-1 through 3-11	Original
4-1 through 4-2	Original
5-1 through 5-5	Original
Index-1 through Index-2	Original

NOTE: Changed text or tables are indicated by a vertical bar adjacent to the changed area. Changed figures are indicated by a vertical bar next to the figure caption. The date appears beside the page number.

Table of Contents



Section 1 Introduction	1-1
Overview	1-1
IEMMU11 and IEMMU12 Module Mounting Units	1-1
IEMMU21 and IEMMU22 Module Mounting Units	1-2
IEMMU01 and IEMMU02 Replacement	1-2
IEMMU01 and IEMMU02 Connection	1-3
Intended User	1-3
Features	1-3
Instruction Content	1-4
How to Use this Instruction	1-4
Glossary of Terms and Abbreviations	1-5
Document Conventions	1-5
Reference Documents	1-5
Nomenclature	1-5
Related Hardware	1-6
Specifications	1-6
Section 2 Description and Operation	2-1
Introduction	2-1
Input Power and Power Distribution	2-1
Power Module Input Power	2-1
Output Power	2-2
I/O Expander Bus	2-3
Controlway	2-3
Overcurrent Protection	2-4
Section 3 Installation	3-1
Introduction	3-1
Tools	3-1
Controlway Segmenting	3-1
Installation	3-2
Transition Board Installation	3-4
Processor Bus Adapter Brackets Installation	3-5
Backplane I/O Connectors	3-6
Section 4 Maintenance	4-1
Introduction	4-1
Preventive Maintenance Schedule	4-1
Equipment and Tools Required	4-1



Table of Contents (continued)

Section 5 Repair and Replacement	5-1
Introduction	5-1
Parts List.....	5-1
Tools	5-2
Backplane Assembly Replacement	5-3
Power Module Removal	5-5

List of Figures

No.	Title	Page
2-1.	MMU Backplane Connector Locations (Module Side)	2-2
3-1.	Controlway Segmenting	3-2
3-2.	Module Mounting Unit Connections	3-4
3-3.	Processor Bus Adapter Brackets Installation	3-7
3-4.	P25 - P35 Pin Location	3-9
3-5.	P1 Connector Pin Location	3-10
3-6.	P2 Connector Pin Location	3-11

List of Tables

No.	Title	Page
1-1.	Glossary of Terms and Abbreviations	1-5
1-2.	Reference Documents	1-5
1-3.	Nomenclature	1-6
1-4.	Related Hardware	1-6
1-5.	Specifications	1-6
1-6.	Amperage Ratings	1-8
2-1.	DC Power Connectors	2-3
3-1.	Controlway Jumper Settings	3-2
3-2.	MMU Cables.....	3-3
3-3.	Input Power Signals.....	3-8
3-4.	Controlway and Regulated Power Supply Signals	3-8
3-5.	Output Signals	3-8
3-6.	P1 Connector	3-9
3-7.	P2 Connector (I/O Expander Bus)	3-10

List of Tables (continued)

<i>No.</i>	<i>Title</i>	<i>Pg.</i>
4-1.	Preventive Maintenance Schedule	4-2
5-1.	Cables	5-1
5-2.	Fasteners	5-1
5-3.	Miscellaneous Parts	5-2



Safety Summary

**GENERAL
WARNINGS**

Equipment Environment

All components, whether in transportation, operation or storage, must be in a noncorrosive environment.

Electrical Shock Hazard During Maintenance

Disconnect power or take precautions to insure that contact with energized parts is avoided when servicing.

**SPECIFIC
WARNINGS**

Disconnect power before installing the processor bus adapter mounting bracket on the module mounting unit backplane. Failure to do so will result in contact with cabinet areas that could cause severe or fatal shock. (p. 3-5)

There are exposed AC and DC connections inside the cabinet. These exposed electrical connections present a shock hazard that can cause injury or death. (p. 5-3)

Handle the module by surfaces other than the heat sink. The heat sink may be hot and may cause severe burns. (p. 5-5)

Allow 30 seconds for the line filter capacitors to discharge before handling the power module. Failure to do so could result in severe or fatal shock. (p. 5-5)

**SPECIFIC
CAUTIONS**

Installation of more than two power modules will result in loss of regulation and voids the warranty. Equipment damage will result. (p. 3-3)

Support Services



Elsag Bailey will provide assistance in the operation and repair of its products. Requests for sales or application services should be made to your nearest sales or service office. Elsag Bailey can also provide installation, repair and maintenance contract services.

When ordering parts, use nomenclature or part numbers and part descriptions from equipment manuals. Parts without a description must be ordered from the nearest sales or service office. Recommended spare parts lists, including prices are available through the nearest sales or service office.

Elsag Bailey has modern training facilities available for training your personnel. On-site training is also available. Contact your nearest Elsag Bailey sales office for specific information and scheduling.

Additional copies of this instruction, or other instructions, can be obtained from the nearest Elsag Bailey sales office at a reasonable charge.



Trademarks and Registrations

Registrations and trademarks used in this document include:

TM Symphony

Trademark of Eltag Bailey Process Automation



Overview

The IEMMU11, IEMMU12, IEMMU21, and IEMMU22 units are module mounting units used to house Harmony rack modules in system cabinets of the Symphony Enterprise Management and Control System. The rack modules include communication, controller, and I/O modules.

NOTE: IEMMU11, IEMMU12, IEMMU21, and IEMMU22 Module Mounting Units can be used as replacements for IEMMU01 and IEMMU02 Module Mounting Units. They can also be installed along with IEMMU01 and IEMMU02 units; however, transition board assemblies are required for interconnection between IEMMU11, IEMMU12, IEMMU21, or IEMMU22 units and IEMMU01 or IEMMU02 units.

The module mounting unit consists of a sheet metal card chassis and a printed circuit board backplane assembly. The open top and bottom structure allows air to flow over the modules. Mounting flanges are provided for mounting the unit in a standard Elsag Bailey Process Automation 483-millimeter (19-inch) cabinet (CAB-01, CAB-04, CAB-12).

Modules can be installed and removed quickly and easily. The module is held in position by card guides, the connectors on the backplane, and the module's front panel, captive fastening latches.

The backplane is a multilayer printed circuit board assembly containing electronic components, dipshunt sockets, connectors, and jumpers. In most cases, the mounting unit provides direct I/O cable coupling to the modules. The exception is when a BRC-100 Harmony Bridge Controller module is installed in the MMU. Refer to **Processor Bus Adapter Brackets Installation** in Section 3 for further explanation.

IEMMU11 and IEMMU12 Module Mounting Units

The IEMMU11 and IEMMU12 units provide physical mounting for up to 12 rack modules or ten rack modules and a maximum of two IEPAS02, IEPDS01/02, IEPAF02, and IEPDF01/02 power modules. They also provide electrical distribution of I/O



expander bus and Controlway signals; distribution of regulated power supply voltages (+5 VDC, +15 VDC, -15 VDC and 24 VDC); and distribution of primary power.

Primary power is the 120/240 VAC or 24/48 VDC that supplies power to power modules (IEPAS02, IEPAF02, IEPDS01, IEPDF01, IEPDS02 and IEPDF02) that can be mounted in the units. Typically, systems that use IEPMU01/02 do not use distributed primary power to the mounting units. Systems that use Modular Power System II do not allow distributed primary power to the mounting units.

The IEMMU11 unit is used when the cabinet configuration requires a rear-mount chassis with primary power distribution.

The IEMMU12 unit is used when the cabinet configuration requires a front-mount chassis with primary power distribution.

IEMMU21 and IEMMU22 Module Mounting Units

The IEMMU21 and IEMMU22 units provide physical mounting for up to 12 rack modules; provide electrical distribution of I/O expander bus and Controlway signals; and distribution of regulated power supply voltages (+5 VDC, +15 VDC, and -15 VDC). The IEMMU21 and IEMMU22 units are the preferred choice for use with Modular Power System II.

The IEMMU21 module mounting unit is used when the cabinet configuration requires a rear-mount chassis with no primary power distribution.

The IEMMU22 mounting unit is used when the cabinet configuration requires a front-mount chassis with no primary power distribution.

IEMMU01 and IEMMU02 Replacement

The IEMMU11, IEMMU12, IEMMU21, and IEMMU22 units are functional equivalents to existing IEMMU01 and IEMMU02 units. The I/O expander bus interconnect cables are different however. The IEMMU11, IEMMU12, IEMMU21, and IEMMU22 units utilize a grey ribbon cable (refer to Table 5-1 for part number) to connect I/O expander bus between adjacent units.

This cable replaces the amber colored interconnect cable used on the IEMMU01 or IEMMU02 unit.

IEMMU01 and IEMMU02 Connection

A transition board (refer to Table 5-3 for part number) is needed if an IEMMU11, IEMMU12, IEMMU21, or IEMMU22 unit is to be connected to an IEMMU01 or IEMMU02 unit. The amber color interconnect cable connects from the IEMMU01 or IEMMU02 unit to the transition board plugged into the IEMMU11, IEMMU12, IEMMU21, or IEMMU22 unit backplane. Refer to **Transition Board Installation** in Section 3 for details.

Intended User

Personnel installing, operating, or maintaining the mounting units should read this manual before performing any installation, maintenance or replacement procedures. Installation requires an engineer or technician with experience in handling electronic circuitry.

Features

The backplane in these mounting units has several features:

- I/O expander bus interconnect cables based on 2.54-millimeter (0.1-inch) center ribbon cable technology for enhanced robustness. Cables come in choice of two lengths: 38 millimeter (1.5 inches) and 171 millimeter (6.75 inches).
- Ability to segment Controlway into three segments on the backplane, which provides for increased density and lower costs.
- Available with or without primary power distribution. Module mounting unit with primary power distribution is only needed for AC and DC Modular Power Systems configured for primary power distribution.



Instruction Content

This instruction contains the following sections:

- Introduction** Contains an overview of the mounting unit, a hardware description, and performance and environmental specifications.
- Description and Operation** Describes and explains the functional and electronic operation of the module mounting unit.
- Installation** Describes mounting procedures and location of the mounting unit in the cabinet. Provides information on I/O expander bus and Controlway connectors as well as jumper settings for segmenting Controlway. This section also contains a processor bus adapter bracket installation procedure necessary to mount a processor bus adapter for a Harmony bridge controller module.
- Maintenance** Provides a maintenance schedule.
- Repair/Replacement Procedures** Details how to replace the mounting unit backplane assembly. It also contains the MMU parts list.

How to Use this Instruction

Read this instruction through in sequence. Read the installation section thoroughly. It is important to become familiar with the entire content of this instruction before installing the modules in the mounting unit.

1. Read and perform all steps in the installation section.
2. Refer to the maintenance section for scheduled maintenance requirements.
3. Refer to the repair and replacement section to find instructions on how to replace the backplane printed circuit board assembly or the mounting unit.
4. Refer to the repair and replacement section for a complete list of parts including part numbers and nomenclatures.

Glossary of Terms and Abbreviations

Table 1-1 lists definitions of abbreviations used in this instruction that are unique to Elsasg Bailey or have a definition that is different from standard industry usage.

Table 1-1. Glossary of Terms and Abbreviations

Term	Definition
Controlway	High speed, redundant, peer-to-peer communication link. Used to transfer information between intelligent modules within a Harmony control unit.
MMU	Module mounting unit. A card chassis that provides electrical and communication support for rack modules.

Document Conventions

The ? in a part number identifies any part number positions that are variable positions (e.g., 1949480?1). The ? is a place holder for the revision letter.

Reference Documents

Table 1-2 lists the documents referenced in this instruction. Refer to this documentation as needed.

Table 1-2. Reference Documents

Number	Document
I-E96-506	AC Modular Power System
I-E96-508	DC Modular Power System
WBPEEU210502?0	Modular Power System II
WBPEEU230017?0	Harmony Bridge Controller

Nomenclature

Table 1-3 is a list of mounting unit nomenclature.



Table 1-3. Nomenclature

1	2	3	4	5	6	7
I	E	M	M	U	-	Module Mounting Unit
					1	1 Rear-mount chassis with primary power distribution
					1	2 Front-mount chassis with primary power distribution
					2	1 Rear-mount chassis without primary power distribution
					2	2 Front-mount chassis without primary power distribution

Related Hardware

Table 1-4 is a list of related hardware.

Table 1-4. Related Hardware

Part Number/ Nomenclature	Description
IEPAF02	AC input field power module
IEPAS02	AC input system power module
IEPDS01	24 VDC input system power module
IEPDS02	48 VDC input system power module
IEPDF01	24 VDC input field power module
IEPDF02	48 VDC input field power module
IEPMU01 IEPMU02	Power mounting unit
1948506?8	System power bus bar
1948516?3	Input power bus bar

Specifications

Table 1-5 lists the specifications for the IEMMU11, IEMMU12, IEMMU21, and IEMMU22 units.

Table 1-5. Specifications

Property	Characteristic/Value
Capacity	12 modules
Mounting	Standard 483-mm (19-in.) cabinet
Ambient temperature (operating)	Temperature rating within the enclosure or cabinet. Internal cabinet rating: 0° to 70°C (32° to 158°F)

Table 1-5. Specifications (continued)

Property	Characteristic/Value
Relative humidity (operating)	5% to 95% up to 55°C (131°F), noncondensing 5% to 45%, up to 70°C (158°F), noncondensing
Storage and transport temperature	−40° to 85°C (−40° to 185°F)
Storage and transport relative humidity	0% to 95%, noncondensing
Air quality	Noncorrosive
Primary power	120/240 VAC, 24/48 VDC (IEMMU11/IEMMU12 only)
Regulated DC voltages	+5 VDC, +15 VDC, −15 VDC, +24 VDC, MCOM, I/OCOM
Amperage ratings	Refer to Table 1-6
EMI/RFI	Meets IEC 1000.3, level 3, 80 MHz to 1 GHz with no loss of function or false status information
Fast transient/burst susceptibility	Meets IEC 1000.4, level 3, mains 2 kV at 2.5 kHz, outputs 1 kV at 5.0 kHz with no loss of function or false status information
Transient surge	Meets IEC 1000.5, level 3, 2 kV with no loss of function or false status information
Electrostatic discharge	Meets IEC 1000.2 level 3, with no loss of function or false status information
Emissions	Meets CISPR11 with amendments 92/31/EEC and 93/68/EEC
Vibration	13.2 to 100 Hz, 0.7 Gs 2 to 13.2 Hz, 12 mm (0.47 in.) p-p displacement
Dimensions	483 × 178 × 304 mm (19 × 7 × 12.2 in.)
Weight	3.63 kg (8.0 lb.)
Certifications	CSA certified for use as process control equipment in an ordinary (non-hazardous) location Nonincendive: CSA: Class I, Division 2, Groups A,B,C,D FM: Class I, Division 2, Groups A,B,C,D CE mark: In compliance with EMC Directive 89/336/EEC, EDS, EFT, RFI and CISPR11 with amendments 92/31/ EEC and 93/68/EEC
Flammability (UL94)	Materials rated at V0, V1, V2 or V5 wires and cables rated UL VW-1
Installation category (IEC 1010-1)	Category I for outputs, Category II for mains Pollution degree I

SPECIFICATIONS SUBJECT TO CHANGE WITHOUT NOTICE



Table 1-6. Amperage Ratings

Voltage	Power Supply Load IEMMU11/12 only (Maximum Amperage)		Module Load (Maximum Amperage)	
	Per Slot	Per MMU	Per Slot	Per MMU
Primary AC power	4	8	N/A	N/A
Primary DC power	6.5	13	N/A	N/A
+5 VDC	13	20 ¹	5	20 ¹
+15 VDC	0.8	1.6	0.225	2.7
-15 VDC	0.8	1.6	0.225	2.7
+24 VDC	4	8	N/A	N/A

NOTE:

1. The stated current rating applies to current flowing into or out of P45 and P46.



Introduction

This section describes and explains the functional and electronic operation of the IEMMU11, IEMMU12, IEMMU21, and IEMMU22 Module Mounting Units.

Input Power and Power Distribution

Regulated power supply voltages (+5 VDC, +15 VDC, -15 VDC, and +24 VDC), PFI, and STATUS signals are distributed to the system through the system power bus bar located inside the cabinet. Power is transferred to the mounting unit from the bus bar through cables. Refer to Figure 3-2 for proper cable usage.

Input AC and DC power is supplied to the IEMMU11 and IEMMU12 units through the input power bus bar located inside the cabinet. Power is transferred to the mounting unit from the bus bar through cables. Refer to Figure 3-2 for proper cable usage.

The IEMMU21 and IEMMU22 units do not provide for distributed input AC and DC power and do not connect to the input power bus bar.

Power Module Input Power

Each IEMMU11 and IEMMU12 unit is capable of housing two power modules (AC or DC). The power module receives its input power through the MMU backplane assembly on connectors P25 through P35 (Fig. 2-1). Pins one, two, and three of connectors P25 through P35 carry the AC power on the backplane assembly while pins four and five carry the DC input power. The input power enters the mounting unit assembly

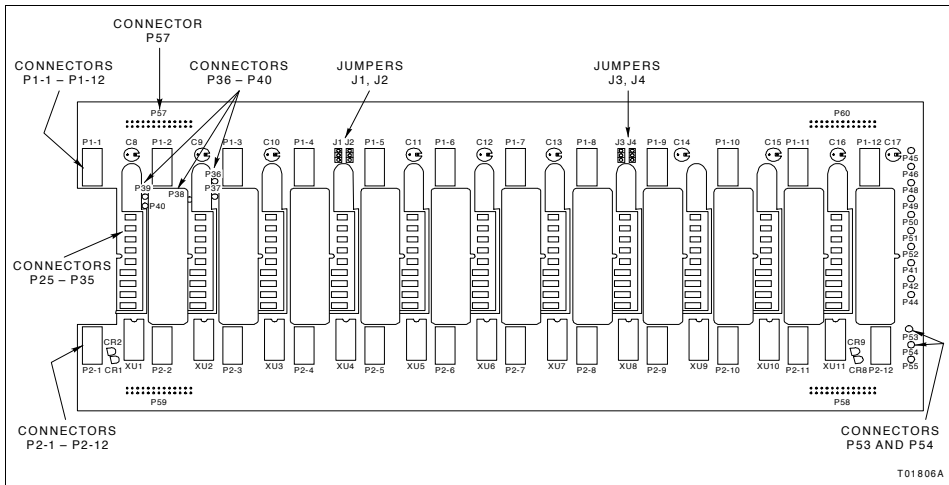

Figure 2-1. MMU Backplane Connector Locations (Module Side)

through connectors P36 through P40. Refer to **Backplane I/O Connectors** in Section 3 for additional information.

NOTES:

1. Power modules **cannot** be installed in slot 12 of the mounting unit.
2. Power modules **cannot** be installed in IEMMU21 or IEMMU22 units.

Output Power

Output power to operate rack modules is distributed to the modules through backplane assembly connectors. Table 2-1 lists the module mounting unit connectors that connect regulated DC voltages from the system power bus bar.

The rack modules which are housed in the mounting unit assembly connect to these bus voltages through connectors P1-1 through P1-12 on the backplane assembly. Refer to **Backplane I/O Connectors** in Section 3 for additional information.

Power modules installed in the module mounting unit provide +5 VDC and +24 VDC to the system through connectors P25 through P35 on the backplane assembly (Fig. 2-1). The

Table 2-1. DC Power Connectors

Signal	Connector
+5 VDC	P45 and P46
+15 VDC	P50
-15 VDC	P51
+24 VDC	P44
Module common (MCOM)	P48 and P49
I/O COM	P42

+15 VDC and -15 VDC are transferred through connectors P1-1 through P1-11.

I/O Expander Bus

Connectors P57 through P60 (located on the four corners of the board) allow connecting the system I/O expander bus between each individual mounting unit (Fig. 2-1). The rack modules located in each mounting unit connect to the expander bus through connectors P2-1 through P2-12 on the backplane assembly. The I/O expander bus connects to P2 connector on the rack modules.

NOTE: I/O expander bus cables are shown in Figure 3-2. If mixing IEMMU11/12/21/22 and IEMMU01/02 units, a transition board is required. The board will not work unless it is used in the left-hand socket of the backplane connector (P58 or P60). The IEMMU01/02 I/O expander bus cable connects to the transition board (refer to Table 5-1 for part number). Additional information is given in **Transition Board Installation** in Section 3.

Dipshunts are located in XU1 through XU11 to allow breaking the expander bus connection between modules as required and dependent on the module configuration.

NOTE: The number one expander bus slot is connected to P57 and P59 whether XU1 is present or not present. The number 12 expander bus slot is connected to P58 and P60 whether XU11 is present or not present.

Controlway

Controlway A enters the mounting unit through connector P53. The signal is distributed through the mounting unit across the backplane assembly and connects to the P1



connector on the rack modules. The bus can be divided into three segments using jumpers J2 and J3. Refer to **Controlway Segmenting** in Section 3 for detailed information.

Controlway B enters the mounting unit through connector P54. The signal is distributed through the mounting unit across the backplane assembly and connects to pin 4 on the P1 connectors. The bus can be divided into three segments using jumpers J1 and J4. Refer to **Controlway Segmenting** in Section 3 for detailed information.

Overcurrent Protection

All input power to the mounting unit is fused and filtered through a power entry panel. The power supplies providing the regulated voltages are fused and filtered.



Introduction

Normally the module mounting unit is already installed in the system cabinet and ready for service. Power and rack modules are usually installed, and the wiring and cable connections are usually completed. This section describes the jumper selections for Controlway segmenting and provides an illustration showing cable connections to and from the mounting unit. It also contains the processor bus adapter (PBA) bracket installation procedure and tables and figures with the mounting unit backplane connector pin assignments. This information is provided in the event that repair or replacement is required.

Tools

The following tools are needed for module mounting unit installation and connection:

- Cable inserter for installing and removing the two five-conductor flat cables for power, PFI, and module status signals on the backplane (refer to Table 5-3 for its part number).

NOTE: The cable inserter is not needed if using individual wires for connecting power, PFI, and module status (Fig. 3-2).

- 16-inch Phillips screwdriver.
- 12-inch flat-blade screwdriver.

Controlway Segmenting

Jumpers J1 through J4 on the mounting unit backplane circuit board split the Controlway signal. Up to three segments can be created. J1 and J4 control bus B while J2 and J3 control bus A. With the jumpers set 2 to 3, the signal continues across the backplane. With the jumpers set 1 to 2, the signal is broken and connected to a separate pull-up circuit. Refer to Figure 3-1 for jumper locations and to Table 3-1 for jumper settings.

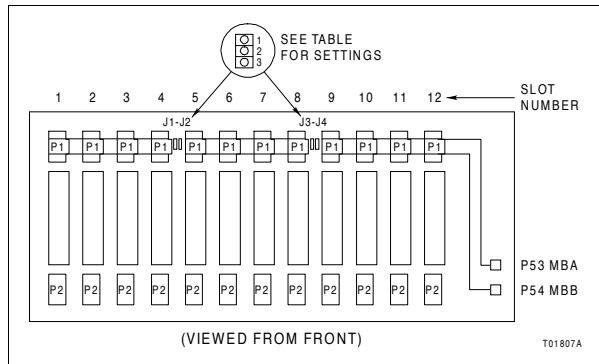

Figure 3-1. Controlway Segmenting

Table 3-1. Controlway Jumper Settings

Jumper	Setting	Controlway
J1 and J2	1-2	MMU slots 1 to 4 isolated from MMU slots 5 to 8
J1 and J2	2-3	MMU slots 1 to 4 connected to MMU slots 5 to 8 (default setting)
J3 and J4	1-2	MMU slots 5 to 8 isolated from MMU slots 9 to 12
J3 and J4	2-3	MMU slots 5 to 8 connected to MMU slots 9 to 12 (default setting)

NOTES:

1. Mounting unit slots 9 through 12 are always connected to P53 and P54.
2. J1 must always be set identical to J2.
3. J3 must always be set identical to J4.

Installation

NOTE: Refer to Table 5-2 for the part numbers for the fasteners described in this installation procedure.

The module mounting unit is mounted to the cabinet mounting rails using four 10-32 clip nuts and four 10-32 × 0.5-inch screws. Notched flanges on the card chassis portion of the mounting unit are used for mounting.

The IEMMU11 and IEMMU21 mount from the rear of the cabinet and the IEMMU12 and IEMMU22 mount from the front of the cabinet.

The IEMMU11 and IEMMU21 units provide physical mounting for up to 12 rack modules, or ten rack modules and a maximum of two power modules. The IEMMU12 and IEMMU22 mounting units provide physical mounting for up to 12 rack modules.

CAUTION

Installation of more than two power modules will result in loss of regulation and voids the warranty. Equipment damage will result.

Table 3-2 and Figure 3-2 provide connection information for systems using an AC modular power system, a DC modular power system, and Modular Power System II.

Table 3-2. MMU Cables (Fig. 3-2)

Cable Number	Part Number/ Nomenclature	Description
1	NKEB01	38-mm (1.5-in.) cable (IEMMU11/12/21/22 only)
	NKEB02	171.5-mm (6.75-in.) cable (IEMMU11/12/21/22 only)
	1948502?0340	Cable (IEMMU01/02 to transition board)
2	1948509?5	Cable — 2 required
	6632285?54	0.84 sq-mm (18 AWG) wire — 10 required
3	6637818?1	Cable
4	6637818?2	Cable
5	6640006?1	Three 0.84 sq-mm (18 AWG) twisted wires

In standard configurations, interconnection between mounting units is accomplished using the NKEB01 expander bus cable. A longer NKEB02 expander bus cable is also available. For information about connecting an IEMMU11, IEMMU12, IEMMU21, or IEMMU22 unit to an IEMMU01 or IEMMU02 unit, refer to **Transition Board Installation** in this section.

Installation and connection of the power system and power modules is described in their respective modular power system instruction. Refer to Table 1-2 for document numbers.

If not all the module slots are being filled, be certain to install the IMBLK01 blank faceplate in any module slot without a module. This plastic shield insures proper cooling (air flow).

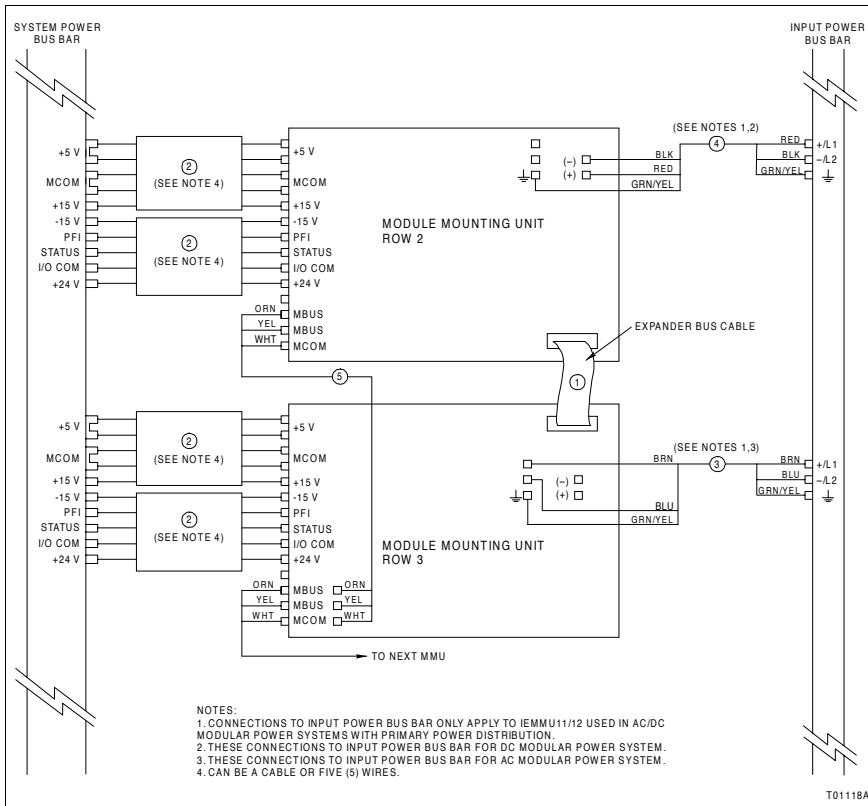

Figure 3-2. Module Mounting Unit Connections (Table 3-2)

Transition Board Installation

When installing an IEMMU11, IEMMU12, IEMMU21, or IEMMU22 unit into a cabinet that is using an IEMMU01 or IEMMU02 unit, a transition board is required for the I/O expander bus connection between the different mounting units (e.g., IEMMU22 unit connected to an IEMMU01 unit).

1. The transition board is installed on the IEMMU11, IEMMU12, IEMMU21, or IEMMU22 unit backplane. With the tabs on the connector (P58 or P60) open, carefully install the

transition board on the pins of the connector and press into position. Be careful not to damage the pins.

NOTE: Transition board assembly must be installed in the left-hand connector socket (as viewed from the rear) of the mounting unit backplane, connector P58 or P60.

2. Squeeze the two tabs on the connector together to lock the transition board in position.
3. Use expander bus interconnect cable (Fig. 3-2). Install the cable onto the transition board by positioning the two locating pins on the cable into the holes on the transition board.
4. Once in place, slide the red plastic locking tab on the cable to secure the cable in position.

Processor Bus Adapter Brackets Installation

NOTE: Refer to Table 5-2 for the part numbers for the fasteners described in this installation procedure.

A processor bus adapter (PBA) must be installed on the back of the module mounting unit when a BRC-100 Harmony Bridge Controller is used. The PBA is necessary to connect the controller to Hnet for communication with a Harmony I/O system. The Hnet bus is the communication path between a BRC-100 module and Harmony I/O blocks.

Installation requires attaching PBA mounting brackets to the back of the module mounting unit, then attaching a PBA assembly to the brackets in each controller module position. The following procedure details PBA mounting brackets installation. Refer to the **Harmony Bridge Controller** instruction for PBA assembly installation and cable connection.

WARNING

Disconnect power before installing the processor bus adapter mounting bracket on the module mounting unit backplane. Failure to do so will result in contact with cabinet areas that could cause severe or fatal shock.

To install the PBA mounting brackets:

1. Turn off power to the cabinet.



2. Remove the top five screws that secure the backplane assembly to the back of the unit.
3. Install one PBA mounting bracket to the top of the module mounting unit backplane assembly using five of the 5-40 screws provided with the brackets (Fig. 3-3).
4. Remove the bottom five screws that secure the backplane assembly to the back of the unit.
5. Install the other mounting bracket to the bottom of the backplane assembly using five 5-40 screws.

Backplane I/O Connectors

Refer to Table 3-3 for a description of connectors P36 through P40. Refer to Table 3-4 for a description of connectors P41 through P55. Figure 2-1 shows the locations of all connectors.

Table 3-5 provides a description of the output signal connectors, P25 through P35. Figure 3-4 shows the pin location.

Table 3-6 provides a description of the P1 connector. Figure 3-5 shows the pin location.

Table 3-7 provides a description of the P2 (I/O expander bus) connector. Figure 3-6 shows the pin location.

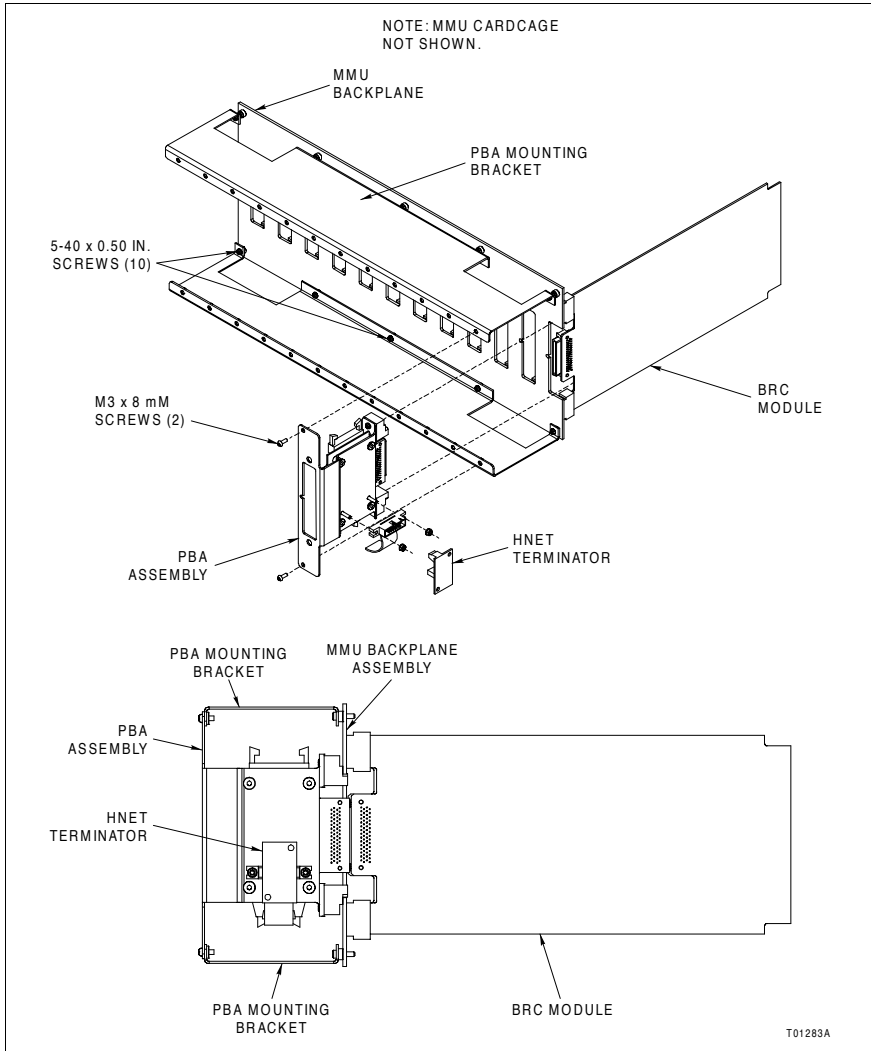

Figure 3-3. Processor Bus Adapter Brackets Installation

**Table 3-3. Input Power Signals**

Signal	Connector
Line	P36
Neutral	P37
Ground	P38
+24V_IN	P40
DCIN_COM	P39

Table 3-4. Controlway and Regulated Power Supply Signals

Signal	Connector
+5V	P45, P46
MCOM	P48, P49, P55
+15V	P50
-15V	P51
PFI	P52
Status	P41
I/O COM	P42
+24V_OUT	P44
MOD_BUSA	P53
MOD_BUSB	P54

Table 3-5. Output Signals

Signal	Connector
Line	P25 - P35, pin 1
Neutral	P25 - P35, pin 2
Ground	P25 - P35, pin 3
DCIN_COM	P25 - P35, pin 4
+24V_IN	P25 - P35, pin 5
MCOM	P25 - P35, pin 6
+5V	P25 - P35, pin 7
I/OCOM	P25 - P35, pin 8
+24V_OUT	P25 - P35, pin 9

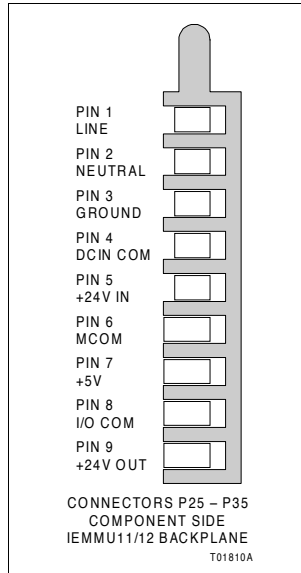

Figure 3-4. P25 - P35 Pin Location

Table 3-6. P1 Connector

Pin No.	Signal
1	+5V
2	+5V
3	Status
4	MOD_BUSB
5	MCOM
6	MCOM
7	+15V
8	-15V
9	PFI
10	Spare 2
11	MOD_BUSA
12	Spare 1

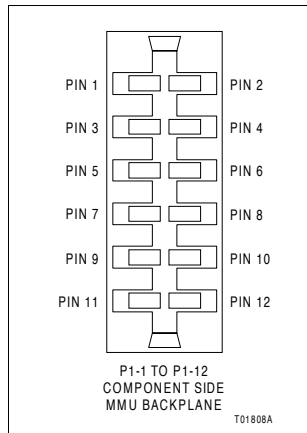

Figure 3-5. P1 Connector Pin Location

Table 3-7. P2 Connector (I/O Expander Bus)

Pin No.	Data Line	Signal
1	A10	Data bit 1
2	A11	Data bit 0
3	A8	Data bit 3
4	A9	Data bit 2
5	A6	Data bit 5
6	A7	Data bit 4
7	A4	Data bit 7
8	A5	Data bit 6
9	A2	Bus clock
10	A3	Synchronization
11	A0	Reserved
12	A1	Reserved

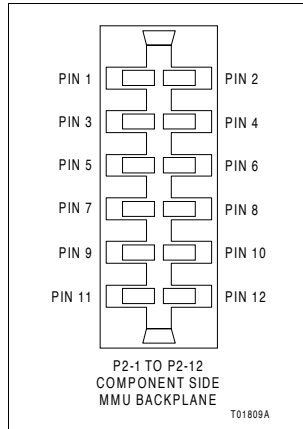

Figure 3-6. P2 Connector Pin Location





Introduction

The reliability of any stand-alone product or control system is affected by the maintenance of the equipment. Elsag Bailey recommends that all equipment users practice a preventive maintenance program that will keep the equipment operating at an optimum level.

This section presents procedures that the customer should be able to perform on site. These preventive maintenance procedures should be used as a guideline to assist in establishing good preventive maintenance practices.

Personnel performing preventive maintenance should meet the following qualifications.

- Maintenance personnel should be qualified electrical technicians or engineers that know the proper use of test equipment.
- Maintenance personnel should be familiar with the mounting unit, have experience working with process control systems, and know what precautions to take when working on live AC and DC systems.

Preventive Maintenance Schedule

Table 4-1 is the preventive maintenance schedule for the mounting unit. The table lists the preventive maintenance tasks in groups according to their specified maintenance interval.

NOTE: The preventive maintenance schedule is for general purposes only. Your application may require special attention.

Equipment and Tools Required

An antistatic vacuum is the only tool required for maintenance procedures.



Table 4-1. Preventive Maintenance Schedule

Task	Frequency
Check cabinet air filters. Clean or replace them as necessary. Check the air filter more frequently in excessively dirty environments.	3 months
Check cabinet and mounting unit backplane assembly for dust. Clean as necessary using an antistatic vacuum.	
Check all signal, power and ground connections within the cabinet that are associated with the mounting unit. Verify that they are secure.	Shutdown
Complete all tasks in this table.	



Introduction

This section includes a listing of the module mounting unit part numbers and nomenclatures, and provides the procedures for removing and replacing the backplane printed circuit board assembly of the module mounting unit.

Parts List

Tables 5-1 and 5-3 comprise the module mounting unit parts list.

Table 5-1. Cables

Part Number/ Nomenclature	Description
NKEB01	38-mm (1.5-in.) expander bus interconnect cable (IEMMU11/12/21/22 only)
NKEB02	171.5-mm (6.75-in.) expander bus interconnect cable (EMMU11/12/21/22 only)
1948502?0340	Expander bus interconnect cable (IEMMU01/02 to transition board)
1948509?5	Flat cable — connects power, PFI, and module status signals between MMU and power bus bar
6632285?54	0.84 sq-mm (18 AWG) wire, faston terminated — connects power, PFI, and module status signals between MMU and system power bus bar
6637818?1	AC power cable to input bus bar
6637818?2	DC power cable to input bus bar
6640006?1	Three 0.84 sq-mm (18 AWG) twisted wires, faston terminated for Controlway interconnection

Table 5-2. Fasteners

Part Number	Description
NDOAC11008	5-40 × 0.5-in. screw
NIDHA16008	10-32 clip nut
NMPCC16002	10-32 × 0.5-in. screw



Table 5-3. Miscellaneous Parts

Part Number/ Nomenclature	Description
IMBLK01	Blank faceplate; located in empty slots in MMU
P-HA-MSC-PBA00000	Processor bus adapter mounting kit
1946715?12	12-position dipshunt connector
1946984?1	Jumper strap for J1 through J4
198494?1	Cable inserter for installing and removing five-conductor flat cables
6642425?1	IEMMU11/12 backplane printed circuit board assembly
6642626?1	IEMMU21/22 backplane printed circuit board assembly
6638748?1	Mounting unit air shield; located in module slots of MMU backplane that do not have modules in place
6642695?1	Transition board assembly ¹ for connecting IEMMU01/02 unit to IEMMU11/12/21/22 unit

NOTE:

1. Transition board assembly must be installed in the left-hand connector socket (as viewed from the rear) of the mounting unit backplane, connector P58 or P60.

Tools

Tools required for replacement procedures are:

- Cable inserter for installing and removing the two five-conductor flat cables for power, PFI, and module status signals on the backplane (refer to Table 5-3 for part number).

NOTE: The cable inserter is not needed if using individual wires for connecting power, PFI, and module status (Fig. 3-2).

- 16-inch Phillips screwdriver.
- 12-inch flat-blade screwdriver.

Backplane Assembly Replacement

WARNING

There are exposed AC and DC connections inside the cabinet. These exposed electrical connections present a shock hazard that can cause injury or death.

To replace the printed circuit board backplane assembly:

1. Turn off power to the cabinet. Open the rear door of the cabinet to gain access to the mounting unit.
2. Tag and disconnect all the cables going to and from the backplane of the mounting unit. Do **not** disconnect the cables attached to the PBA assemblies if present. The cable connections can remain intact. Use Eltag Bailey's cable inserter tool to remove the two five-conductor flat cables for PFI, power, and status signals.
3. From the front of the cabinet, remove all of the rack modules from the mounting unit. If the mounting unit contains any power modules, refer to **Power Module Removal** for the correct procedure and important safety guidelines.

NOTE: To remove the entire mounting unit from the cabinet, remove the four screws that attach it to the cabinet side rails.

4. If PBA assemblies are attached to the back of the MMU, remove them and the PBA mounting brackets. If not, go to step 5.
 - a. Remove the two screws that fasten each PBA assembly to the PBA mounting brackets (Fig. 3-3). The cable connections can remain intact.
 - b. Remove the five screws that hold the bottom PBA mounting bracket in place.

NOTE: The screws that attach the two PBA mounting brackets also attach the backplane assembly. Be sure to hold the backplane assembly while removing the brackets.
 - c. Remove the five screws that hold the top mounting bracket in place.
 - d. Go to step 6.



5. Remove the ten screws securing the backplane assembly to the rack.
6. Before installing the new backplane assembly, make certain jumpers J1 through J4 are set correctly. Refer to **Control-way Segmenting** in Section 3.
7. Before installing the new backplane assembly, make certain dipshunts in sockets XU1 through XU11 are configured the same as on the backplane being replaced.
8. If PBA assemblies and their mounting brackets were removed earlier, reinstall them. If not, go to step 9.
 - a. Position the new backplane assembly on the mounting unit assembly.
 - b. Install one PBA mounting bracket to the top of the module mounting unit backplane assembly using the five screws previously removed (Fig. 3-3).
 - c. Install the remaining mounting bracket to the bottom of the backplane assembly using the five screws previously removed.
 - d. Verify the PBA assembly cable connections are still intact and secure.
 - e. Install the PBA assemblies removed previously.
 - f. Go to step 10.
9. Position the new backplane assembly on the mounting unit assembly. Install the ten screws previously removed.
10. From the rear of the cabinet, connect all cables removed in Step 2. Use the identification tags to aid in proper connection. Use the connector inserter tool to install the two five-conductor flat cables.
11. Turn on power to the cabinet.
12. From the front of the cabinet, align the top and bottom edges of the module circuit board with the guides in the mounting unit slot.
13. Hold the module by the thumbscrews on the faceplate and firmly push it into the slot. Push until the rear edge connectors are firmly seated in the backplane connectors.

14. Turn the thumbscrews until the module is secured in the mounting slot.
15. Verify the status LEDs turn green.

Power Module Removal

If the mounting unit has power modules installed, use the following procedures to remove them.

1. Use a flat blade screwdriver to turn the two concentric screws $\frac{1}{2}$ -turn in either direction on the power module being removed.

WARNING Handle the module by surfaces other than the heat sink. The heat sink may be hot and may cause severe burns.

2. Grasp the handle on the power module faceplate and partially pull the module from the mounting unit.

WARNING Allow 30 seconds for the line filter capacitors to discharge before handling the power module. Failure to do so could result in severe or fatal shock.

3. Allow at least 30 seconds for the line filter capacitors to discharge then remove it completely from the mounting unit.





A	
AC/DC power distribution	2-1
Air shield	3-3
B	
Backplane I/O connectors	3-6
Bus voltages	2-2
C	
Connections	
Input power bus bar	3-3
System power bus bar	3-3
Controlway	2-3
Segmenting	3-1
Conventions, document	1-5
F	
Features	1-3
Front mount chassis	1-1
G	
Glossary	1-5
H	
Harmony bridge controller	3-5
I	
I/O expander bus	2-3
Dipshunts	2-3
IEMMU01	
Connection	1-3
Replacement	1-2
IEMMU02	
Connection	1-3
Replacement	1-2
IEMMU11	1-1
IEMMU12	1-1
IEMMU21	1-2
IEMMU22	1-2
Installation	
Connections	3-3
Jumpers	3-1
Mounting	3-2
Power system	3-3
Processor bus adapter	3-5
Tools	3-1
Transition board	3-4
Instruction content	1-4
Intended user	1-3
J	
Jumpers J1 through J4	3-1
M	
Maintenance	4-1
N	
Nomenclature	1-5
O	
Overcurrent protection	2-4
Overview	1-1
P	
Parts list	5-1
Power	
Distribution	2-1
Input	2-1
Output	2-2
Overcurrent protection	2-4
Power module input power	2-1
Power modules	1-1, 2-1, 2-2
Primary power	1-2
Processor bus adapter	3-5
Mounting brackets	3-5



Index (continued)

R	S
Rear mount chassis 1-2	Specifications 1-6
Reference documents 1-5	
Related hardware 1-6	
Replacement	T
Backplane assembly 5-3	Transition board 3-4
Power module removal 5-5	
Tools 5-2	

Visit Elsasg Bailey on the World Wide Web at <http://www.ebpa.com>

Our worldwide staff of professionals is ready to meet *your* needs for process automation.
For the location nearest you, please contact the appropriate regional office.

AMERICAS

29801 Euclid Avenue
Wickliffe, Ohio USA 44092
Telephone 1-440-585-8500
Telefax 1-440-585-8756

ASIA/PACIFIC

152 Beach Road
Gateway East #20-04
Singapore 189721
Telephone 65-391-0800
Telefax 65-292-9011

EUROPE, AFRICA, MIDDLE EAST

Via Puccini 2
16154 Genoa, Italy
Telephone 39-10-6582-943
Telefax 39-10-6582-941

GERMANY

Graefstrasse 97
D-60487 Frankfurt Main
Germany
Telephone 49-69-799-0
Telefax 49-69-799-2406

Form WBPEEU1200502A0 Litho in U.S.A. 398
Copyright © 1998 by Elsasg Bailey Process Automation, as an Unpublished Work
® Registered Trademark of Elsasg Bailey Process Automation
™ Trademark of Elsasg Bailey Process Automation

