



## EXTER™-series Operator Panels

---

Service and Maintenance Manual

English

## Service and Maintenance Manual for EXTER Operator Panels

### Foreword

This manual contains detailed information about the EXTER- operator panels, including descriptions of various actions that can be carried out in order to maintain or update the operator panel hardware and software.

The manual is intended for persons that should be able to carry out basic maintenance and replace common parts in an EXTER-series operator panel.

The manual assumes that the most recent versions of the system program (firmware) and configuration tool are used.

Please see the Information Designer Reference Manual (MAEN749x) for a description of the configuration tool and the installation manuals for information regarding installation.

Function-based descriptions are available in the User's Guide (MAEN750x).

© Beijer Electronics AB, MAEN757C, 2009-02

The information in this document is subject to change without notice and is provided as available at the time of printing. Beijer Electronics AB reserves the right to change any information without updating this publication. Beijer Electronics AB assumes no responsibility for any errors that may appear in this document. All examples in this document are only intended to improve understanding of the functionality and handling of the equipment. Beijer Electronics AB cannot assume any liability if these examples are used in real applications. In view of the wide range of applications for this software, users must acquire sufficient knowledge themselves in order to ensure that it is correctly used in their specific application. Persons responsible for the application and the equipment must themselves ensure that each application is in compliance with all relevant requirements, standards and legislation in respect to configuration and safety. Beijer Electronics AB will accept no liability for any damage incurred during the installation or use of equipment mentioned in this document. Beijer Electronics AB prohibits all modification, changes or conversion of the equipment.

# Contents

<b>1</b>	<b>Safety Precautions</b> .....	<b>5</b>
1.1	UL and cUL Installation .....	5
1.2	General .....	5
1.3	During Installation .....	6
1.4	During Use .....	6
1.5	Service and Maintenance.....	6
1.6	Dismantling and Scrapping.....	6
<b>2</b>	<b>Introduction</b> .....	<b>7</b>
2.1	General .....	7
2.2	Maintenance .....	10
2.3	Service and Repairs .....	10
2.4	Dismantling and Scrapping.....	10
2.5	Contact and Support.....	10
<b>3</b>	<b>Hardware</b> .....	<b>11</b>
3.1	General Information about Hardware .....	11
3.2	Hardware Tests .....	11
3.3	Hardware Specification .....	12
3.3.1	Keyboard Operated Panels.....	12
3.3.2	Touch Screen Operated Panels.....	16
3.3.3	Sun-Readable Panels .....	19
3.4	Functionality Specification.....	20
3.5	Additional Hardware .....	22
3.5.1	Memory Card .....	22
3.6	Hardware Replacement .....	24
3.6.1	Mode Switches.....	24
3.6.2	Cables .....	25
3.6.3	Replacing the Rear Cover.....	26
3.6.4	Replacing the Display/Display Cable .....	28
3.6.5	Self-test of the Display .....	37
3.6.6	Calibrate the Touch Screen.....	37
3.6.7	Replacing the Complete Front .....	38
3.6.8	Replacing the Battery .....	40
3.6.9	Replacing the Backlight .....	42
3.6.10	Available Spare Parts .....	45
3.7	Service Menu .....	49
3.7.1	Network Settings .....	49
3.7.2	Erase Project Memory.....	49
3.7.3	Load Project from Memory Card.....	49
3.7.4	Enter Transfer Mode .....	49
3.7.5	Enter Run Mode.....	49
3.7.6	Update System Program from Memory Card.....	49
3.7.7	Calibrate Touch Screen.....	49

3.8	Hardware Self Test .....	50
3.9	Additional Installation Tips .....	51
3.9.1	Grounding the Operator Panel .....	51
3.9.2	Ethernet Connection in the Panel .....	52
3.9.3	To Achieve Better EMC Protection .....	53
3.9.4	Ambient Temperature .....	54
3.9.5	Safety .....	55
3.9.6	Galvanic Isolation .....	56
3.9.7	Cable and Bus Termination RS485 .....	57
3.10	Fault Tracing .....	58
<b>4</b>	<b>Software .....</b>	<b>59</b>
4.1	General Information about Software .....	59
4.1.1	Software Products .....	59
4.2	Update Software .....	60
4.2.1	Information Designer .....	60
4.2.2	Remote Access Viewer .....	60
4.2.3	Image Loader .....	60
4.2.4	System Program .....	61
<b>5</b>	<b>Environmental Aspects .....</b>	<b>63</b>
5.1	General Environmental Aspects .....	63
5.2	Environmental Impact of the Operator Panels .....	63
5.2.1	Mechanical Components .....	63
5.2.2	Electronics .....	63
5.3	Recycling .....	64
5.4	Environmental Impact Report .....	64

# 1 Safety Precautions

Both the installer and the owner and/or operator of the operator panel must read and understand this installation manual.

## 1.1 UL and cUL Installation

- This equipment is suitable for use in Class I, Division 2, Groups A, B, C and D OR non-hazardous locations only. [Combinations of equipment in your system are subject to investigation by the local Authority Having Jurisdiction at the time of installation.]
- Maximum ambient temperature 40 °C when mounted horizontal or 50 °C when mounted vertical.
- WARNING – EXPLOSION HAZARD – Do not disconnect equipment unless power has been removed or the area is known to be non-hazardous.
- For Canada also AVERTISSEMENT – RISQUE D’EXPLOSION – AVANT DE DECONNECTER L’EQUIPEMENT, COUPER LE COURANT OU S’ASSURER QUE L’EMPLACEMENT EST DESIGNE NON DANGEREUX.
- WARNING – EXPLOSION HAZARD - Substitution of components may impair suitability for Class I, Division 2.
- For Canada also AVERTISSEMENT – RISQUE D’EXPLOSION – LA SUBSTITUTION DE COMPOSANTS PEUT RENDRE CE MATERIEL INACCEPTABLE POUR LES EMBLEMES DE CLASSE I, DIVISION 2.
- WARNING – EXPLOSION HAZARD – only UL and cUL approved expansion units are allowed to be connected to the port designated “EXPANSION”. At the moment there are no such units evaluated or allowed.
- WARNING – EXPLOSION HAZARD - Do not replace expansion unit unless power has been switched off or the area is known to be non-hazardous.
- This product contains battery, this must only be changed in an area known to be non-hazardous. Permitted types are shown in the section [Hardware Specification](#).
- For use on a flat surface of a type 4X enclosure indoor use only.
- To make wiring connections to the power supply connector, use an AWG 28-12 cable and a tightening torque of min. 0.5 Nm.

## 1.2 General

- Read the safety precautions carefully.
- Check the delivery for transportation damage. If damage is found, notify the supplier as soon as possible.
- Do not use the operator panel in an environment with high explosive hazards.
- The supplier is not responsible for modified, altered or reconstructed equipment.
- Use only parts and accessories manufactured according to specifications of the supplier.
- Read the installation and operating instructions carefully before installing, using or repairing the operator panel.
- Never allow fluids, metal filings or wiring debris to enter any openings in the operator panel. This may cause fire or electrical shock.
- Only qualified personnel may operate the operator panel.
- Storing the operator panel where the temperature is lower/higher than recommended in this manual can cause the LCD display liquid to congeal/become isotopic.

- The LCD display liquid contains a powerful irritant. In case of skin contact, wash immediately with plenty of water. In case of eye contact, hold the eye open, flush with plenty of water and get medical attention.
- The figures in this manual serves an illustrative purpose. Because of the many variables associated with any particular installation, the supplier cannot assume responsibility for actual use based on the figures.
- The supplier neither guarantees that the operator panel is suitable for your particular application, nor assumes responsibility for your product design, installation or operation.

### **1.3 During Installation**

- The operator panel is designed for stationary installation on a plane surface, where the following conditions are fulfilled:
  - no high explosive risks
  - no strong magnetic fields
  - no direct sunlight
  - no large, sudden temperature changes
- Install the product according to the accompanying installation instructions.
- Ground the product according to the accompanying installation instructions.
- Only qualified personnel may install the operator panel.
- Separate the high voltage, signal and supply cables.
- Make sure that the voltage and polarity of the power source is correct before connecting the product to the power outlet.
- Peripheral equipment must be appropriate for the application and location.

### **1.4 During Use**

- Keep the operator panel clean.
- Emergency stop and other safety functions may not be controlled from the operator panel.
- Do not use too much force or sharp objects when touching the keys, touch screen etc.

### **1.5 Service and Maintenance**

- Only qualified personnel should carry out repairs.
- The agreed warranty applies.
- Before carrying out any cleaning or maintenance operations, disconnect the equipment from the electrical supply.
- Clean the display and surrounding front cover with a soft cloth and mild detergent.
- Replacing the battery incorrectly may result in explosion. Only use batteries recommended by the supplier.

### **1.6 Dismantling and Scrapping**

- The operator panel or parts thereof shall be recycled according to local regulations.
- The following components contain substances that might be hazardous to health and the environment: lithium battery, electrolytic capacitor and display.

## 2 Introduction

This manual describes how to maintain EXTER series operator panels. The functions available in the configuration tool depend on which operator panel model is used.




The descriptions of the EXTER panels include the sun-readable panels as well, except for in the *Hardware Specification* section, and for some hardware replacement actions, where the EXTER sun-readable panels are specified separately.





The manual is divided into the following sections:

- *Safety Precautions*
- *Introduction*
- *Hardware*
- *Software*
- *Environmental Aspects*





### 2.1 General

The HMI range offers six different sized keypad-operated models and five touch screen models. The different operator panels are listed in the table below:

Operator Panel	Description	Drawings
EXTER K10m (also referred to as BEPP K10)	160 x 32 pixels display with keypad 	<i>Outline drawing</i> <i>Panel cut-out</i> <i>Text strip</i>
EXTER K20m (also referred to as BEPP K20)	240 x 64 pixels display with keypad 	<i>Outline drawing</i> <i>Panel cut-out</i> <i>Text strip</i>
EXTER K30 (also referred to as BEPP K30)	240 x 64 pixels display with keypad 	<i>Outline drawing</i> <i>Panel cut-out</i> <i>Text strip</i>

Operator Panel	Description	Drawings
EXTER K60/ EXTER K60c/ EXTER K60m (also referred to as BEPP K60)	5.7" display with keypad 	<a href="#">Outline drawing</a> <a href="#">Panel cut-out</a> <a href="#">Text strip</a>
EXTER K70 (also referred to as BEPP 64K)	6.5" display with keypad 	<a href="#">Outline drawing</a> <a href="#">Panel cut-out</a> <a href="#">Text strip</a>
EXTER K100 (also referred to as BEPP 104K)	10.4" display with keypad 	<a href="#">Outline drawing</a> <a href="#">Panel cut-out</a> <a href="#">Text strip</a>
EXTER T40/ EXTER T40m (also referred to as BEPP T40)	3.5" touch screen display 	<a href="#">Outline drawing</a> <a href="#">Panel cut-out</a>



Operator Panel	Description	Drawings
EXTER T60/ EXTER T60c/ EXTER T60m (also referred to as BEPP T60)	5.7" touch screen display 	<a href="#">Outline drawing</a> <a href="#">Panel cut-out</a>
EXTER T70 (also referred to as BEPP 64T)	6.5" touch screen display 	<a href="#">Outline drawing</a> <a href="#">Panel cut-out</a>
EXTER T100 (also referred to as BEPP 104T)	10.4" touch screen display 	<a href="#">Outline drawing</a> <a href="#">Panel cut-out</a>
EXTER T150 (also referred to as BEPP 150T)	15" touch screen display 	<a href="#">Outline drawing</a> <a href="#">Panel cut-out</a>

## 2.2 Maintenance

Carefully read the instructions before beginning maintenance on the operator panel.

- Only qualified personnel should carry out maintenance.
- The agreed warranty and license agreements apply.
- Any damage to the operator panel caused by personnel invalidates the warranty.
- Before carrying out any cleaning or maintenance operations, disconnect the operator panel from the power supply.
- Clean the display and surrounding front cover with a soft cloth and mild detergent. Recommended cleaning fluids for the display are water and IPA (Isopropyl Alcohol or Hexane).
- Replacing the battery incorrectly may result in explosion. Only use batteries recommended by the supplier.
- A 6-month warranty on all service parts is provided.

Maintenance personnel are permitted to carry out the following actions:

- *Replacing the Rear Cover*
- *Replacing the Battery*
- *Replacing the Backlight*
- *Replacing the Complete Front*

## 2.3 Service and Repairs

- Only accredited companies are permitted to perform service and repairs.
- If a non-accredited company conducts any kind of service or repair, the agreed warranty will be invalidated.
- If training is required, contact the supplier.
- All maintenance should be performed in a 15-30 °C temperature range.
- Any damage to the operator panel caused by personnel invalidates the warranty.
- Contracts with customers supersede the information in this document.

## 2.4 Dismantling and Scrapping

- The operator panel, or parts thereof, should be recycled according to local regulations.
- The following components contain substances that might be hazardous to health and the environment: lithium battery, electrolytic capacitor, display.

## 2.5 Contact and Support

If you want to report a fault or have a question about the operator panels, please contact your local supplier or fill out the form on the web site.

1. Enter the web site [www.beijerelectronics.com](http://www.beijerelectronics.com) and select **Support**.
2. Select **Contact** in the menu. Make sure to provide information about type number, serial number, environment and an installation description.

The form will be sent to the manufacturer's help desk and they will answer your question or register your improvement/fault.

To ensure quick resolution, provide as many details as possible in your report. Include the date and time when the problem occurred, a description of what you were trying to do, the detailed steps you took that led up to the problem, and details about any error messages received.

## 3 Hardware

This chapter describes how to maintain the EXTER operator panel hardware. The chapter includes general information, hardware tests and certificates, technical data, a hardware replacement guide, and a fault tracing section.

### 3.1 General Information about Hardware

Before the operator panels are approved for market introduction, they are tested by independent authorities. The EXTER operator panels are examined by several authorities before being approved for market introduction. All operator panels are designed to fulfill CE, UL, and other standards. The quality policy and environmental policy place demands on all suppliers and subcontractors.

### 3.2 Hardware Tests

The manufacturer performs extensive hardware testing before an operator panel is approved. Some tests are performed by external testing companies, such as the Swedish National Testing and Research Institute.

All operator panels are submitted to testing before leaving the manufacturer.

### 3.3 Hardware Specification

#### 3.3.1 Keyboard Operated Panels

The tables below presents technical data for the keyboard operated panels.

Parameter	EXTER K10m	EXTER K20m
Front panel, W x H x D	155 x 114 x 6 mm	155 x 155 x 6 mm
Mounting depth	46.4 mm (146.4 mm including clearance)	
Front panel seal	IP 66	
Rear panel seal	IP 20	
Keyboard material	Membrane switch keyboard with metal domes. Overlay film of Autotex F207 with print on reverse side. 1 million operations.	
Reverse side material	Powder-coated aluminum	
Weight	0.45 kg	0.55 kg
Serial port RS422/RS485	25-pin D-sub contact, chassis-mounted female with standard locking screws 4-40 UNC.	
Serial port RS232C	9-pin D-sub contact, male with standard locking screws 4-40 UNC.	
Ethernet	Connection via Ethernet is made using the Ethernet Expansion Module, mounted on the back of the operator panel.	
Flash memory for application	512 kB	
Real time clock	±20 PPM + error because of ambient temperature and supply voltage. Total maximum error: 1 min/month at 25 °C Temperature coefficient: -0.04 ppm/°C <sup>2</sup>	
Rechargeable real time clock battery	MS614S (UL and cUL: SII Micro Parts LTD)	
Power consumption at rated voltage	Normal: 0.1 A Maximum: 0.3 A	
Display	FSTN-LCD, 160 x 32 pixels, monochrome transmissive negative.	FSTN-LCD, 240 x 64 pixels, monochrome transmissive negative.
	LED backlight lifetime at the ambient temperature of +25 °C: >47.000 h	
Active area of display, W x H	89.6 x 17.9 mm	90.2 x 24.0 mm
Fuse	Internal DC fuse 1.0 AT, 5x20 mm	
Power supply	+24V DC (20 - 30V DC). 3-pin jack connection block. CE: The power supply must conform with the requirements according to IEC 60950 and IEC 61558-2-4. UL and cUL: The power supply must conform with the requirements for class II power supplies.	
Ambient temperature	0 ° to +50 °C	
Storage temperature	-20 ° to +70 °C	
Relative humidity	5 - 85 % non-condensed	
Approvals	Please refer to <a href="http://www.beijerelectronics.com">www.beijerelectronics.com</a> for information	

Technical Data	EXTER K30m
Front panel, W x H x D	202 x 187 x 6 mm
Mounting depth	57 mm (157 mm including clearance)
Front panel seal	IP 66
Rear panel seal	IP 20
Keyboard material	Membrane switch keyboard with metal domes. Overlay film of Autotex F157 with print on reverse side. 1 million operations.
Reverse side material	Powder-coated aluminum
Weight	0.95 kg
Serial port RS422/RS485	25-pin D-sub contact, chassis-mounted female with standard locking screws 4-40 UNC.
Serial port RS232C	9-pin D-sub contact, male with standard locking screws 4-40 UNC.
Ethernet	Shielded RJ 45
USB	Host type A (USB 1.1), max output current 500 mA
Flash memory for application	12 MB (incl. fonts)
Real time clock	±20 PPM + error because of ambient temperature and supply voltage. Total maximum error: 1 min/month at 25 °C Temperature coefficient: $-0.034 \pm 0.006$ ppm/°C <sup>2</sup>
Real time clock battery	CR2450 (UL and cUL: Sanyo or Panasonic) Minimum lifetime: 3 years
Power consumption at rated voltage	Normal: 0.15 A Maximum: 0.35 A
Display	FSTN-LCD, 240 x 64 pixels, monochrome transfective. LED backlight lifetime at the ambient temperature of +25 °C: >35,000 h.
Active area of display, W x H	127.0 x 33.8 mm
Fuse	Internal DC fuse, 2.0 AT, 5 x 20 mm
Power supply	+24V DC (20 - 30V DC). 3-pin jack connection block. CE: The power supply must conform with the requirements according to IEC 60950 and IEC 61558-2-4. UL and cUL: The power supply must conform with the requirements for class II power supplies.
Ambient temperature	Vertical installation: 0 ° to +50 °C Horizontal installation: 0 ° to +40 °C
Storage temperature	-20 ° to +70 °C
Relative humidity	5 - 85 % non-condensed
Approvals	Please refer to <a href="http://www.beijerelectronics.com">www.beijerelectronics.com</a> for information

Technical Data	EXTER K60	EXTER K60m	EXTER K60c
Front panel, W x H x D	275 x 168 x 6 mm		
Mounting depth	57 mm (157 mm including clearance)		
Front panel seal	IP 66		
Rear panel seal	IP 20		
Keyboard material	Membrane switch keyboard with metal domes. Overlay film of Autotex F157 with print on reverse side. 1 million operations.		
Reverse side material	Powder-coated aluminum		
Weight	1.2 kg		
Serial port RS422/ RS485	25-pin D-sub contact, chassis-mounted female with standard locking screws 4-40 UNC.		
Serial port RS232C	9-pin D-sub contact, male with standard locking screws 4-40 UNC.		
Ethernet	Shielded RJ 45		
USB	Host type A (USB 1.1), max output current 500 mA		
Flash memory for application	12 MB (incl. fonts)		
Real time clock	±20 PPM + error because of ambient temperature and supply voltage. Total maximum error: 1 min/month at 25 °C Temperature coefficient: $-0.034 \pm 0.006 \text{ ppm}/^{\circ}\text{C}^2$		
Real time clock battery	CR2450 (UL and cUL: Sanyo or Panasonic) Minimum lifetime: 3 years		
Power consumption at rated voltage	Normal: 0.2 A Maximum: 0.4 A		Normal: 0.3 A Maximum: 0.5 A
Display	TFT-LCD, 320 x 240 pixels, 64K colors.	TFT-LCD, 320 x 240 pixels, 16 greyscales.	Transmissive color STN-LCD, 320 x 240 pixels, 64K colors.
	LED backlight lifetime at the ambient temperature of +25 °C: >20,000 h.		CCFL backlight lifetime at the ambient temperature of +25 °C: >75,000 h.
Active area of display, W x H	115.2 x 86.4 mm		
Fuse	Internal DC fuse, 2.0 AT, 5 x 20 mm		
Power supply	+24V DC (20 - 30V DC). 3-pin jack connection block. CE: The power supply must conform with the requirements according to IEC 60950 and IEC 61558-2-4. UL and cUL: The power supply must conform with the requirements for class II power supplies.		
Ambient temperature	Vertical installation: 0 ° to +50 °C Horizontal installation: 0 ° to +40 °C		
Storage temperature	-20 ° to +70 °C		
Relative humidity	5 - 85 % non-condensed		
Approvals	Please refer to <a href="http://www.beijerelectronics.com">www.beijerelectronics.com</a> for information		

Technical Data	EXTER K70	EXTER K100
Front panel, W x H x D	285 x 177 x 6 mm	382 x 252 x 6 mm
Mounting depth	56 mm (156 mm including clearance)	58 mm (158 mm including clearance)
Front panel seal	IP 66	
Rear panel seal	IP 20	
Keyboard material	Membrane switch keyboard with metal domes. Overlay film of Autotex F157 with print on reverse side. 1 million operations.	
Reverse side material	Powder-coated aluminum	
Weight	1.4 kg	2.5 kg
Serial port RS422/RS485	25-pin D-sub contact, chassis-mounted female with standard locking screws 4-40 UNC.	
Serial port RS232C	9-pin D-sub contact, male with standard locking screws 4-40 UNC.	
Ethernet	Shielded RJ 45	
USB	Host type A (USB 1.1), max output current 500mA Device type B (USB 1.1)	
CF-slot	Compact flash, type I and II	
Flash memory for application	12 MB (incl. fonts)	
Real time clock	±20 PPM + error because of ambient temperature and supply voltage. Total maximum error: 1 min/month at 25 °C Temperature coefficient: -0.034±0.006 ppm/°C <sup>2</sup>	
Real time clock battery	CR2450 (UL and cUL: Sanyo or Panasonic) Minimum lifetime: 3 years	
Power consumption at rated voltage	Normal: 0.4 A Maximum: 0.9 A	Normal: 0.5 A Maximum: 1.0 A
Display	TFT-LCD, 640 x 480 pixels, 64K colors.	TFT-LCD, 800 x 600 pixels, 64K colors.
	CCFL backlight lifetime at the ambient temperature of +25 °C: >50,000 h.	
Active area of display, W x H	131.5 x 98.6 mm	211.2 x 158.4 mm
Fuse	Internal DC fuse, 3.15 AT, 5 x 20 mm	
Power supply	+24V DC (20 - 30V DC). 3-pin jack connection block. CE: The power supply must conform with the requirements according to IEC 60950 and IEC 61558-2-4. UL and cUL: The power supply must conform with the requirements for class II power supplies.	
Ambient temperature	Vertical installation: 0 ° to +50 °C Horizontal installation: 0 ° to +40 °C	
Storage temperature	-20 ° to +70 °C	
Relative humidity	5 - 85 % non-condensed	
Approvals	Please refer to <a href="http://www.bejerelectronics.com">www.bejerelectronics.com</a> for information	

### 3.3.2 Touch Screen Operated Panels

The tables below presents technical data for the touch screen operated panels.

Technical Data	EXTER T40	EXTER T40m
Front panel, W x H x D	155.8 x 119 x 6 mm	
Mounting depth	57 mm (157 mm including clearance)	
Front panel seal	IP 66	
Rear panel seal	IP 20	
Touch screen material	Touch screen: Polyester on glass, 1 million finger touch operations. Overlay: Autotex F157/F207.	
Reverse side material	Powder-coated aluminum	
Weight	0.6 kg	
Serial port RS422/ RS485	25-pin D-sub contact, chassis-mounted female with standard locking screws 4-40 UNC.	
Serial port RS232C	9-pin D-sub contact, male with standard locking screws 4-40 UNC.	
Ethernet	Shielded RJ 45	
USB	Host type A (USB 1.1), max output current 500 mA	
Flash memory for application	12 MB (incl. fonts)	
Real time clock	±20 PPM + error because of ambient temperature and supply voltage. Total maximum error: 1 min/month at 25 °C Temperature coefficient: -0.034±0.006 ppm/°C <sup>2</sup>	
Real time clock battery	CR2450 (UL and cUL: Sanyo or Panasonic) Minimum lifetime: 3 years	
Power consumption at rated voltage	Normal: 0.15 A Maximum: 0.35 A	
Display	TFT-LCD, 320 x 240 pixels, 64K colors.	TFT-LCD, 320 x 240 pixels, 16 greyscales.
	LED backlight lifetime at the ambient temperature of +25 °C: >10,000 h.	
Active area of display, W x H	70.1 x 52.6 mm	
Fuse	Internal DC fuse, 2.0 AT, 5 x 20 mm	
Power supply	+24V DC (20 - 30V DC). 3-pin jack connection block. CE: The power supply must conform with the requirements according to IEC 60950 and IEC 61558-2-4. UL and cUL: The power supply must conform with the requirements for class II power supplies.	
Ambient temperature	Vertical installation: 0 ° to +50 °C Horizontal installation: 0 ° to +40 °C	
Storage temperature	-20 ° to +70 °C	
Relative humidity	5 - 85 % non-condensed	
Approvals	Please refer to <a href="http://www.beijerelectronics.com">www.beijerelectronics.com</a> for information	



Technical Data	EXTER T60c	EXTER T60m	EXTER T60	EXTER T60m of hardware version type no 07600 or higher
Front panel, W x H x D	202 x 152 x 6 mm			
Mounting depth	57 mm (157 mm including clearance)			
Front panel seal	IP 66			
Rear panel seal	IP 20			
Touch screen material	Touch screen: Polyester on glass, 1 million finger touch operations. Overlay: Autotex F157/F207.			
Reverse side material	Powder-coated aluminum			
Weight	0.9 kg			
Serial port RS422/RS485	25-pin D-sub contact, chassis-mounted female with standard locking screws 4-40 UNC.			
Serial port RS232C	9-pin D-sub contact, male with standard locking screws 4-40 UNC.			
Ethernet	Shielded RJ 45			
USB	Host type A (USB 1.1), max output current 500 mA			
Flash memory for application	12 MB (incl. fonts)			
Real time clock	±20 PPM + error because of ambient temperature and supply voltage. Total maximum error: 1 min/month at 25 °C Temperature coefficient: -0.034±0.006 ppm/°C <sup>2</sup>			
Real time clock battery	CR2450 (UL and cUL: Sanyo or Panasonic) Minimum lifetime: 3 years			
Power consumption at rated voltage	Normal: 0.25 A Maximum: 0.45 A		Normal: 0.2 A Maximum: 0.4 A	
Display	Transmissive color STN-LCD, 320 x 240 pixels, 64K colors	Transmissive monochrome STN-LCD, 320 x 240 pixels	TFT-LCD, 320 x 240 pixels, 64K colors.	TFT-LCD, 320 x 240 pixels, 16 greyscales.
	CCFL backlight lifetime at the ambient temperature of +25 °C: >75,000 h.	CCFL backlight lifetime at the ambient temperature of +25 °C: >58,000 h.	LED backlight lifetime at the ambient temperature of +25 °C: >20,000 h.	
Active area of display, W x H	115.2 x 86.4 mm			
Fuse	Internal DC fuse, 2.0 AT, 5 x 20 mm			
Power supply	+24V DC (20 - 30V DC). 3-pin jack connection block. CE: The power supply must conform with the requirements according to IEC 60950 and IEC 61558-2-4. UL and cUL: The power supply must conform with the requirements for class II power supplies.			
Ambient temperature	Vertical installation: 0 ° to +50 °C Horizontal installation: 0 ° to +40 °C			
Storage temperature	-20 ° to +70 °C			
Relative humidity	5 - 85 % non-condensed			
Approvals	Please refer to <a href="http://www.beijerelectronics.com">www.beijerelectronics.com</a> for information			

Technical Data	EXTER T70	EXTER T100	EXTER T150
Front panel, W x H x D	219 x 154 x 6 mm	302 x 228 x 6 mm	398 x 304 x 6 mm
Mounting depth	56 mm (156 mm including clearance)	58 mm (158 mm including clearance)	60 mm (160 mm including clearance)
Front panel seal	IP 66		
Rear panel seal	IP 20		
Touch screen material	Touch screen: Polyester on glass, 1 million finger touch operations. Overlay: Autotex F157 or F207.		
Reverse side material	Powder-coated aluminum		
Weight	1.2 kg	2.1 kg	3.7 kg
Serial port RS422/ RS485	25-pin D-sub contact, chassis-mounted female with standard locking screws 4-40 UNC.		
Serial port RS232C	9-pin D-sub contact, male with standard locking screws 4-40 UNC.		
Ethernet	Shielded RJ 45		
USB	Host type A (USB 1.1), max output current 500mA Device type B (USB 1.1)		
CF-slot	Compact flash, type I and II		
Flash memory for application	12 MB (incl. fonts)		
Real time clock	±20 PPM + error because of ambient temperature and supply voltage. Total maximum error: 1 min/month at 25 °C Temperature coefficient: -0.034±0.006 ppm/°C <sup>2</sup>		
Real time clock battery	CR2450 (UL and cUL: Sanyo or Panasonic) Minimum lifetime: 3 years		
Power consumption at rated voltage	Normal: 0.4 A Maximum: 0.9 A	Normal: 0.5 A Maximum: 1.0 A	Normal: 1.2 A Maximum: 1.7 A
Display	TFT-LCD, 640 x 480 pixels, 64K colors	TFT-LCD, 800 x 600 pixels, 64K colors	TFT-LCD, 1024 x 768 pixels, 64K colors
	CCFL backlight lifetime at the ambient temperature of +25 °C:		
	>50,000 h		>35,000 h
Active area of display, W x H	131.5 x 98.6 mm	211.2 x 158.4 mm	304.1 x 228.1 mm
Fuse	Internal DC fuse, 3.15 AT, 5 x 20 mm		
Power supply	+24V DC (20 - 30V DC). 3-pin jack connection block. CE: The power supply must conform with the requirements according to IEC 60950 and IEC 61558-2-4. UL and cUL: The power supply must conform with the requirements for class II power supplies.		
Ambient temperature	Vertical installation: 0 ° to +50 °C Horizontal installation: 0 ° to +40 °C		
Storage temperature	-20 ° to +70 °C		
Relative humidity	5 - 85 % non-condensed		
Approvals	Please refer to <a href="http://www.beijerelectronics.com">www.beijerelectronics.com</a> for information		

### 3.3.3 Sun-Readable Panels

The tables below presents technical data for the sun-readable panels.

Technical Data	EXTER T70sr	EXTER T100sr	EXTER T150sr
Front panel, W x H x D	219 x 154 x 6 mm	302 x 228 x 6 mm	398 x 304 x 6 mm
Mounting depth	56 mm (156 mm including clearance)	58 mm (158 mm including clearance)	60 mm (160 mm including clearance)
Front panel seal	IP 66		
Rear panel seal	IP 20		
Touch screen material	Touch screen: Polyester on glass, 2 million finger touch operations. Overlay: Autotex XE.		
Reverse side material	Powder-coated aluminum		
Weight	1.2 kg	2.1 kg	3.9 kg
Serial port RS422/ RS485	25-pin D-sub contact, chassis-mounted female with standard locking screws 4-40 UNC.		
Serial port RS232C	9-pin D-sub contact, male with standard locking screws 4-40 UNC.		
Ethernet	Shielded RJ 45		
USB	Host type A (USB 1.1), max output current 500mA Device type B (USB 1.1)		
CF-slot	Compact flash, type I and II		
Flash memory for application	12 MB (incl. fonts)		
Real time clock	±20 PPM + error because of ambient temperature and supply voltage. Total maximum error: 1 min/month at 25 °C Temperature coefficient: -0.034±0.006 ppm/°C <sup>2</sup>		
Real time clock battery	CR2450 (UL and cUL: Sanyo or Panasonic) Minimum lifetime: 3 years		
Power consumption at rated voltage	Normal: 0.4 A Maximum: 0.9 A	Normal: 0.5 A Maximum: 1.0 A	Normal: 1.2 A Maximum: 1.7 A
Display	TFT-LCD. 640 x 480 pixels, 64K color.	TFT-LCD. 800 x 600 pixels, 64K color.	TFT-LCD. 1024 x 768 pixels, 64K color.
	CCFL backlight lifetime at the ambient temperature of +25 °C: >50,000 h.		
Active area of display, W x H	132.5 x 99.4 mm	211.2 x 158.4 mm	304.1 x 228.1 mm
Fuse	Internal DC fuse, 3.15 AT, 5 x 20 mm		
Power supply	+24V DC (20 - 30V DC). 3-pin jack connection block. CE: The power supply must conform with the requirements according to IEC 60950 and IEC 61558-2-4. UL and cUL: The power supply must conform with the requirements for class II power supplies.		
Ambient temperature	Vertical installation: 0 ° to +50 °C Horizontal installation: 0 ° to +40 °C		
Storage temperature	-20 ° to +70 °C		
Relative humidity	5 - 85 % non-condensed		
Approvals	Please refer to <a href="http://www.beijerelectronics.com">www.beijerelectronics.com</a> for information		

### 3.4 Functionality Specification

Function Specification	EXTER K30m, EXTER K60/K60c/K60m, EXTER K70, EXTER K100, EXTER T40/T40m, EXTER T60/T60c/T60m, EXTER T70, EXTER T100 and EXTER T150
Network Abilities (Ethernet/Internet)	E-mail (SMTP client) Web server Remote operation Access to controller system Transfer of files (FTP server)
Dual Drivers with Data Exchange	Yes
Passthrough / Transparent Mode	Yes (depending on driver)
No Protocol Mode	Yes
Multiple Languages	Yes, with up to 10 languages in one project
Standard Windows Fonts (Unicode)	Yes
Data Logger	Yes
Internal Variables	Yes
Historic Trends	Yes
Recipe Management	Yes
Alarm Management	Yes, with up to 16 alarm groups
Time Channels	Yes
I/O Poll Groups	Yes
Security Passwords	Yes, up to 8 levels
Message Libraries	Yes
Macros	Yes
Dynamic Objects	Yes
Report Printouts	Yes
Easy Configuration with Information Designer	Yes

Function Specification	EXTER K10m and EXTER K20m
Network Abilities (Ethernet/Internet)	Access to controller system - Connection via Ethernet is made using the Ethernet Expansion Module, mounted on the back of the operator panel.
Dual Drivers with Data Exchange	Yes
Passthrough / Transparent Mode	Yes (depending on driver)
No Protocol Mode	Yes
Multiple Languages	Yes, with up to 10 languages in one project
Standard Windows Fonts (Unicode)	No
Data Logger	No
Internal Variables	Yes
Historic Trends	No. EXTER K20m supports real time trend. EXTER K10m does not support trend project at all.
Recipe Management	Yes
Alarm Management	Yes, with one alarm group
Time Channels	Yes
I/O Poll Groups	No
Security Passwords	Yes, up to 8 levels
Message Libraries	Yes
Macros	Yes
Dynamic Objects	Yes
Report Printouts	Yes, via serial printer
Easy Configuration with Information Designer	Yes

## 3.5 Additional Hardware

### 3.5.1 Memory Card

An internal Compact Flash memory card can be used in the EXTER K70, EXTER K100, EXTER T70, EXTER T100 and EXTER T150 operator panels for expansion of the project memory.

---

**Note:**

When using an internal Compact Flash memory card, no external Compact Flash memory card can be used. An external USB Flash drive can be used for the same functions as an external Compact Flash card.

---

Compact Flash cards of type I and II are supported.

Compact Flash cards of the following brands and models are recommended:

SiliconSystems SiliconDrive
SanDisk Industrial Grade
Cactus 203-, 302- and 303-series

Due to product changes and upcoming brands, other Compact Flash cards may be approved as EXTER accessories even if they are not present in the above list.

#### Installation

Perform the following steps to install an internal Compact Flash card in the operator panel:

1. Turn off the power to the panel.

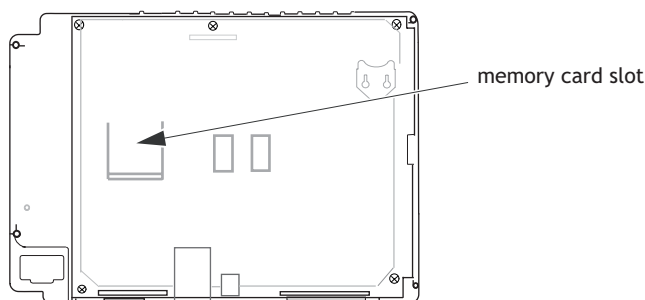
---

**Note:**

Make sure to use adequate ESD protection.

---

2. Follow the instructions under [Replacing the Rear Cover](#) to remove the rear cover.
3. Flip the back cover; the CPU board is mounted inside the back cover.
4. Insert the Compact Flash memory card in its slot on the CPU board.



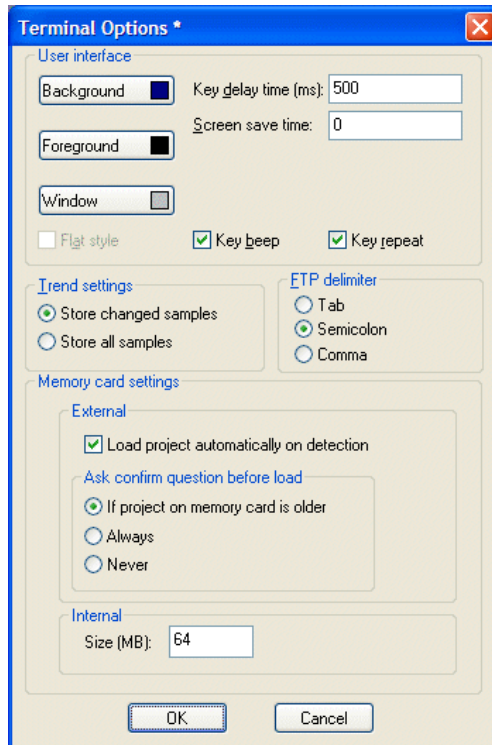
5. Re-attach the back cover to the operator panel.
6. Turn on the power to the operator panel.

When the operator panel starts up, you will be asked if you like to move the files to the internal card; select **YES** to this question.

## Settings in Information Designer

The size of the internal memory card must be entered in the configuration tool for the operator panel.

1. Select **Setup/Terminal Options**.
2. Enter the size of the internal memory card under **Memory card settings/Internal**.



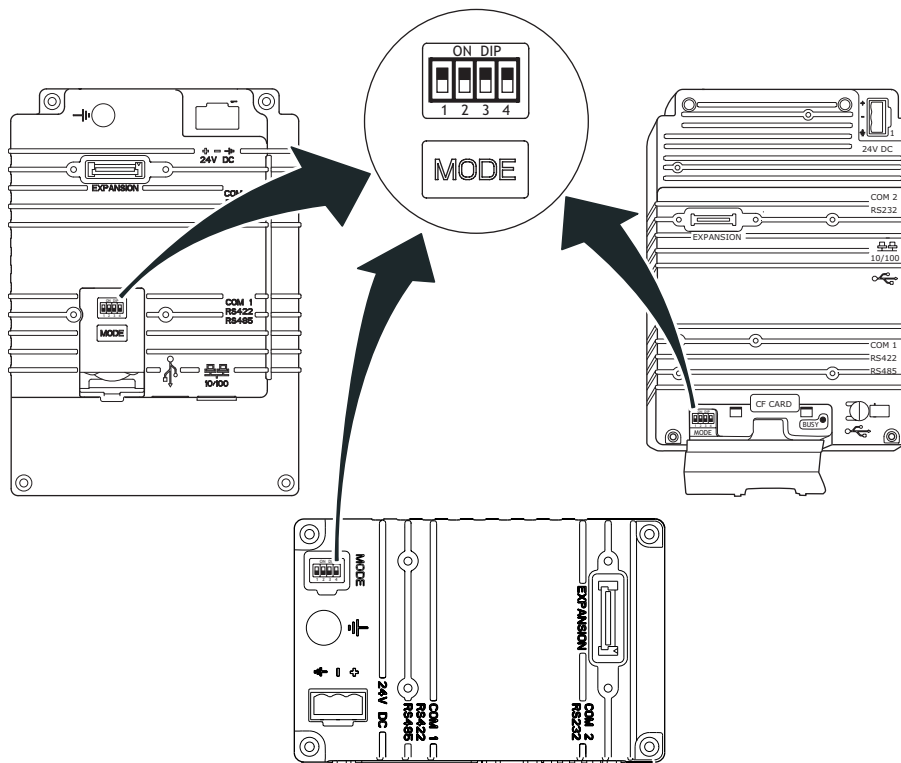
3. Click **OK** to close the dialog.

## 3.6 Hardware Replacement

This section contains instructions on how to replace operator panel hardware. Only components included in the latest bill of material and spare parts list are allowed. See [Available Spare Parts](#).

### 3.6.1 Mode Switches

The EXTER operator panels have four mode switches (DIP switches) located on the rear side of the operator panel.




---

#### Warning:

The modes below are to be used with caution.

---

The mode switches have the following functions:

1=ON, 0=OFF

Each letter in “MODE” has a corresponding mode switch

MODE	Description for EXTER K10m and EXTER K20m
0000	“Run-mode” - Normal operation.
0010	System Restore, resets the file system. Restores the operator panel to factory settings. <b>Warning!</b> Information can easily accidentally be lost.
0100	Image Load mode (Sysload) allows upgrading of the firmware in the operator panel.
1000	Service Menu mode, the service menu for the system program is shown. Allows the user to set IP configuration, erase the project etc. See section <a href="#">Service Menu</a> for details.
1110	Self-Test.



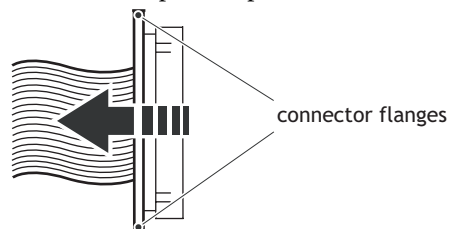
MODE	Description for EXTER K30m, EXTER K60/K60c/K60m, EXTER K70, EXTER K100, EXTER T40/T40m and EXTER T60/T60c/T60m, EXTER T70, EXTER T100 and EXTER T150
0000	"Run-mode" - Boot CE, normal operation.
0010	System Restore, resets the file system and registry, reinstalls the system program (OPsys_bxxx.CAB). Restores the operator panel to factory settings. <b>Warning!</b> Information can easily accidentally be lost.
0100	Image Load mode (Sysload) allows upgrading of the firmware in the operator panel. <b>Note:</b> All files including the file system in the operator panel will be deleted when upgrading with Image Loader.
1000	Service Menu mode, the service menu for the system program is shown. Allows the user to set IP configuration, erase the project, calibrate the touch screen, set the panel in Run/Transfer mode etc. See section <a href="#">Service Menu</a> for details.
1100	Not used (Run-mode).
1110	Self-Test.
xxx1	Hard reset (forces the system to reset).

To change mode switches, follow the steps below:

1. Disconnect power from the operator panel.
2. Set the mode switches using a ballpoint pen.
3. Reconnect power to the operator panel.

### 3.6.2 Cables

Most of the operator panels use the same type of flex cable connectors.



*Flex cable connector*

To release the flex cables from the connector, gently push the two flanges on the cable connector towards the flex cable.

---

**Note:**

The connectors must be unlocked on both sides before removing the cable, otherwise the flex cable may be damaged.

---

### 3.6.3 Replacing the Rear Cover

The following is needed:

- A new rear cover.
- A torx T10 screwdriver.

---

**Note:**

Make sure you have adequate ESD protection.

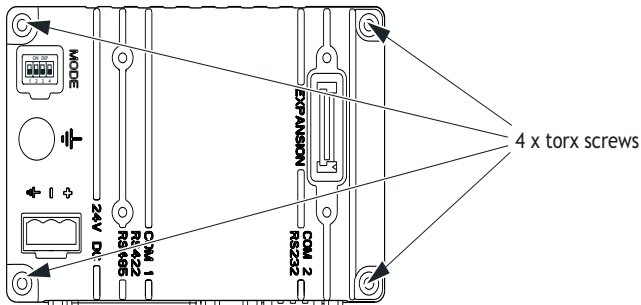
---

**EXTER K10m, EXTER K20m, EXTER K30m, EXTER K60/K60c/K60m, EXTER T40/T40m and EXTER T60/T60c/T60m**

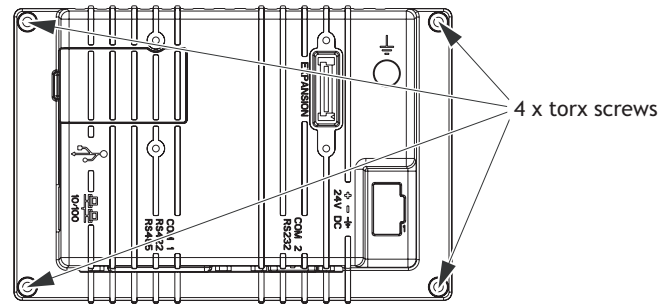
To replace the rear cover you will need a new rear cover, see the [Available Spare Parts](#) section.

Then follow the steps below:

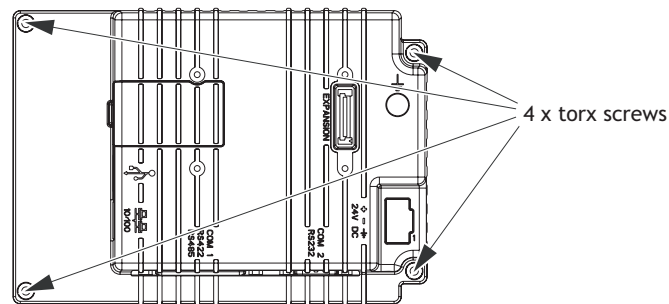
1. Power off the operator panel.
2. Follow the instructions [Replacing the Battery](#) to remove the battery.
3. Remove the rear cover of the operator panel by loosening the 4 torx screws.



*Illustration of EXTER K10m and EXTER K20m.*



*Illustration of EXTER K30m*



*Illustration of EXTER K60/60c/K60m and EXTER T60/T60c/T60m*

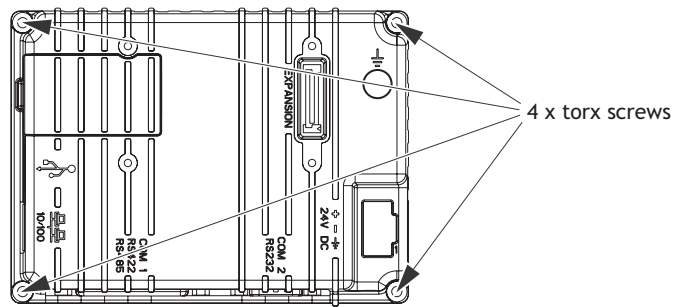


Illustration of EXTER T40/T40m

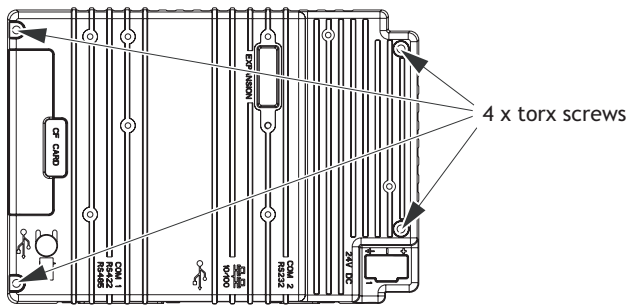
4. Re-assemble with the new rear cover in reverse order.

### EXTER K70, EXTER K100, EXTER T70, EXTER T100 and EXTER T150

To replace the rear cover you will need a new rear cover, see the [Available Spare Parts](#) section.

Then follow the steps below:

1. Power off the operator panel.
2. Remove the rear cover of the operator panel by loosening the 4 torx screws.



3. Re-assemble with the new rear cover in reverse order.

### 3.6.4 Replacing the Display/Display Cable

The following is needed:

- A new display or a new display cable, see *Available Spare Parts*.
- A torx T10 screwdriver.
- Two plain screwdrivers.

---

**Note:**

Make sure you have adequate ESD protection.

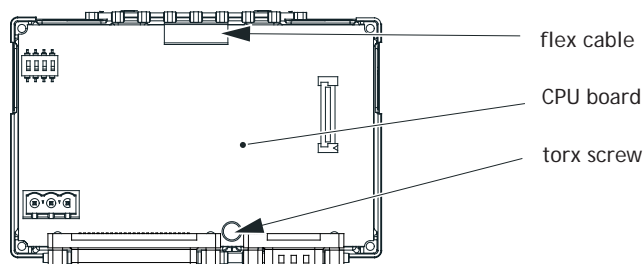
---

#### EXTER K10m and EXTER K20m

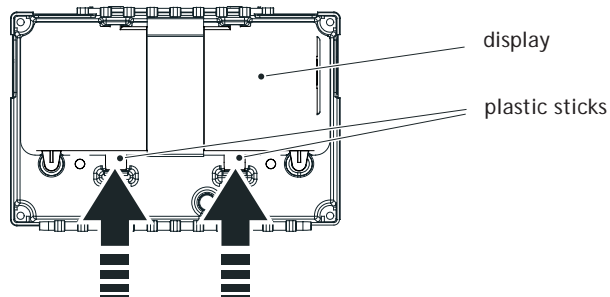
To replace the display you will need a new display including display frame, see the *Available Spare Parts* section.

Follow the steps below:

1. Power off the operator panel.
2. Follow the instructions under *Replacing the Rear Cover* to remove the rear cover.
3. Unlock the flex cable connector by pressing the connector flanges towards the cable and disconnect the flex cable from the CPU board.  
The connector must be unlocked on both sides before removing the cable.



4. Loosen the torx screw as shown in the illustration above to release the CPU board.  
Then carefully lift the CPU board
5. Disconnect the flex cable on the back side of the CPU board and then remove the CPU board.
6. Push the two plastic sticks towards the top of the panel to unlock the display from the aluminum casing.



7. Mount the new display unit.
8. Re-assemble the panel in reverse order.

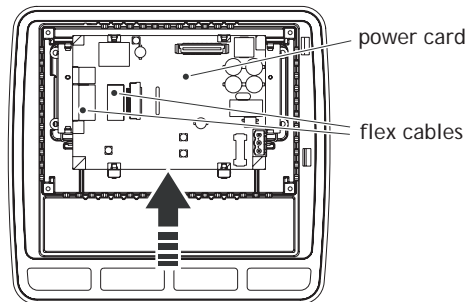
### EXTER K30m

To replace the display you will need a new display including display frame, see the [Available Spare Parts](#) section.

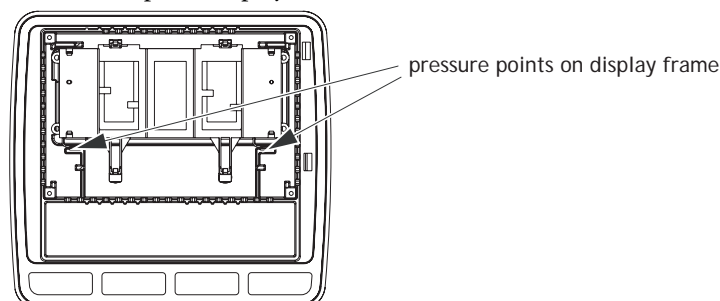
Follow the steps below:

1. Power off the operator panel.
2. Follow the instructions under [Replacing the Rear Cover](#) to remove the rear cover.
3. Unlock the two flex cable connectors by pressing the connector flanges towards the cable and disconnect the flex cables from the power card.

The connectors must be unlocked on both sides before removing the cables.



4. Gently press the power card towards the top of the panel as shown in the illustration above to release the power card from the power card holders. Then tilt the bottom of the card away from you.
5. Disconnect the two flex cables and the plain cable on the back side of the power card and then remove the power card.
6. Insert the two screwdrivers between the display frame and the aluminum casing illustrated below. Press and bend gently on the display frame to unlock the frame and tilt up the display frame.



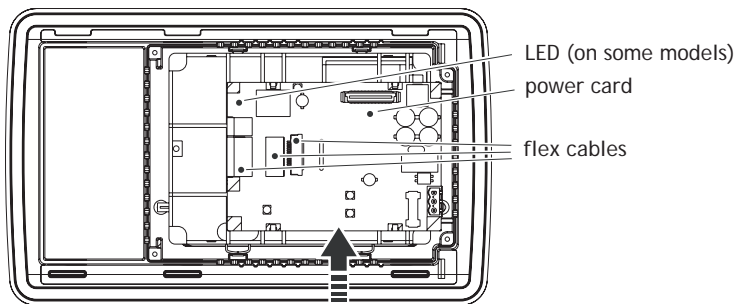
7. Mount the new display unit.
8. Re-assemble the panel in reverse order.

**EXTER K60/K60c/K60m**

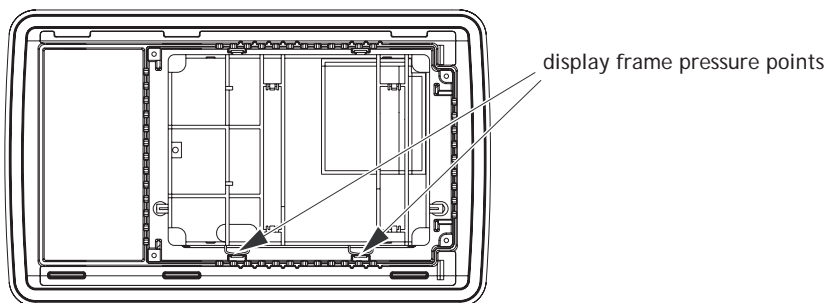
To replace the display you will need a new display including display frame, see the [Available Spare Parts](#) section.

Follow the steps below:

1. Power off the operator panel.
2. Follow the instructions under [Replacing the Rear Cover](#) to remove the rear cover.
3. Unlock the three flex cable connectors by pressing the connector flanges towards the cable and disconnect the flex cables from the power card.  
The connectors must be unlocked on both sides before removing the cables.
4. Disconnect LED cable, if applicable.



5. Gently press the power card towards the top of the panel as shown in the illustration above to release the power card from the power card holders.  
Then tilt the bottom of the card away from you.
6. Disconnect the plain cable on the back side of the power card and remove the power card.
7. Insert the two screwdrivers between the display frame and the aluminum casing illustrated below. Press and bend gently on the display frame to unlock the frame and tilt up the display frame.



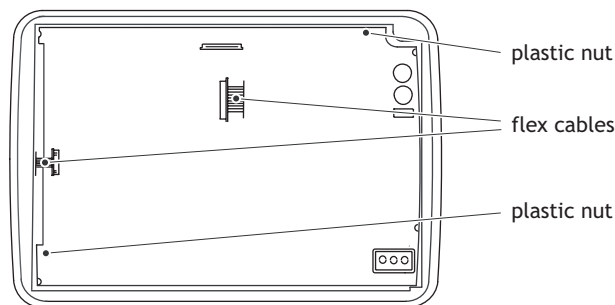
8. Mount the new display unit.
9. Re-assemble the panel in reverse order.

## EXTER K70 and EXTER T70

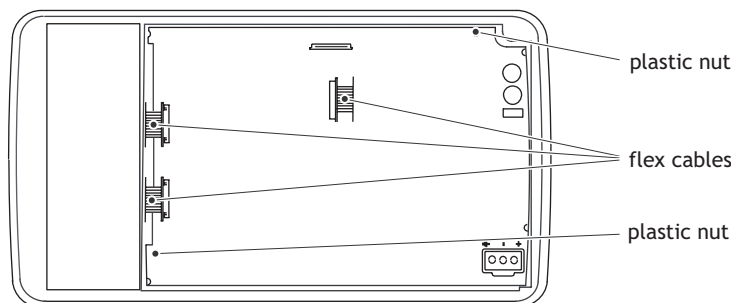
To replace the display/display cable you will need a new display including plastic frame and display cable, see the [Available Spare Parts](#) section.

Follow the steps below:

1. Power off the operator panel.
2. Follow the instructions under [Replacing the Rear Cover](#) to remove the rear cover.
3. Disconnect the two (EXTER T70) or three (EXTER K70) flex cables from the power card, according to the illustration below, and remove the two plastic nuts that holds the power card in place.
4. For the EXTER T70sr model, there is also a cable underneath the power card - disconnect this cable as well.

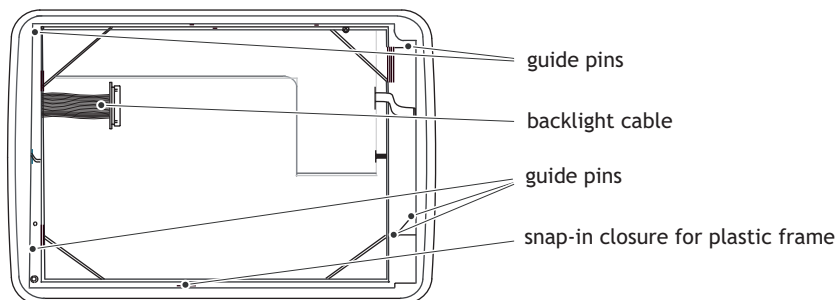


*Illustration of EXTER T70 showing the two flex cables*



*Illustration of EXTER K70 showing three flex cables*

5. Lift the power card and gently remove the backlight cable from the rear side.

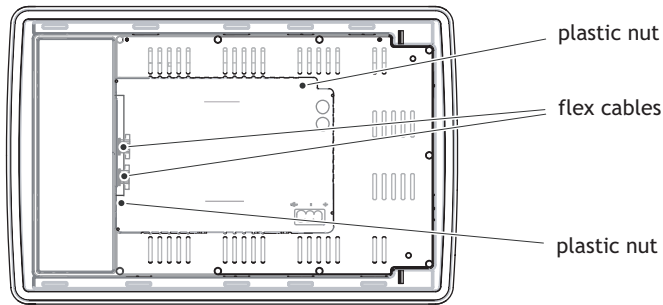


6. Gently loosen the complete plastic frame and display from the front plate.  
Scrap the display and frame.
7. Mount the new display/display cable and frame and re-assemble the complete operator panel. Make sure the guide pins on the frame are properly fastened in the holes in the front plate.
8. Re-assemble the complete operator panel.

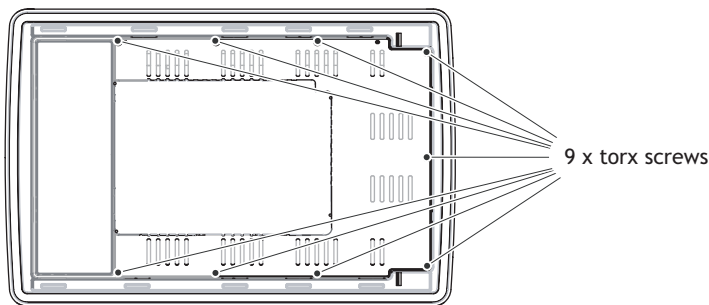
**EXTER K100**

Follow the steps below to replace the display/display cable of EXTER K100:

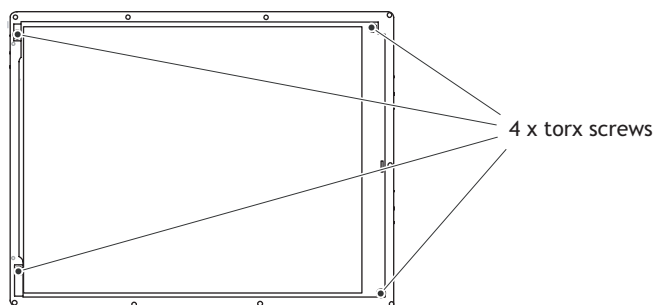
1. Power off the operator panel.
2. Follow the instructions under [Replacing the Rear Cover](#) to remove the rear cover.
3. Disconnect the two flex cables from the power card and remove the two plastic nuts that keep the power card in place.



4. Lift the power card and gently remove the 2 backlight cables and the display cable from the rear side of the power card.
5. Remove the mounting plate (9 torx screws). Gently lift the mounting plate with the display and power card.



6. Flip the mounting plate and unscrew the 4 torx screws.



7. Make sure the display cable is attached to the new display before reattaching the mounting plate.
8. Re-assemble the complete operator panel.

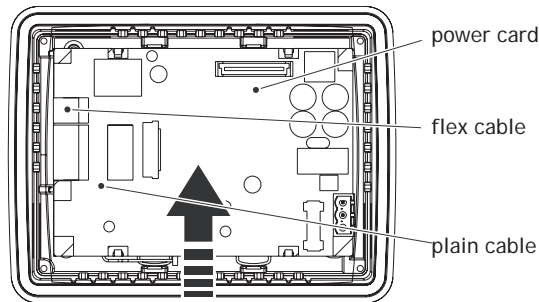


## EXTER T40/T40m

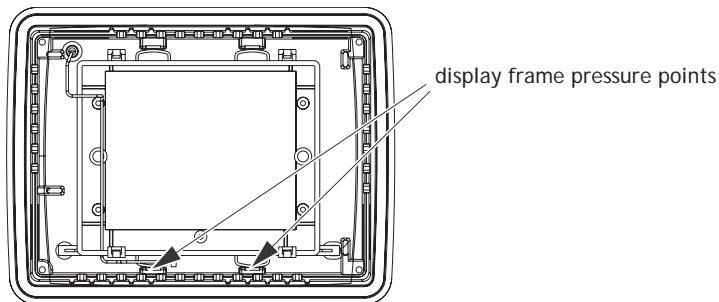
To replace the display you will need a new display including display frame, see the [Available Spare Parts](#) section.

Follow the steps below:

1. Power off the operator panel.
2. Follow the instructions under [Replacing the Rear Cover](#) to remove the rear cover.
3. Unlock the flex cable connector by pressing the connector flanges towards the cable and disconnect the flex cable and the plain cable from the power card.  
The connector must be unlocked on both sides before removing the cables.



4. Gently press the power card towards the top of the panel as shown in the illustration above to release the power card from the power card holders. Then tilt the bottom of the card away from you.
5. Disconnect the flex cable on the back side of the power card and remove the power card.
6. Insert the two screwdrivers between the display frame and the aluminum casing illustrated below. Press and bend gently on the display frame to unlock the frame and tilt up the display frame.



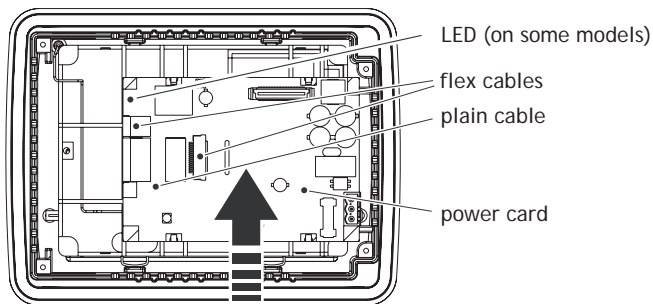
7. Mount the new display unit.
8. Re-assemble the complete operator panel.

### EXTER T60/T60c/T60m

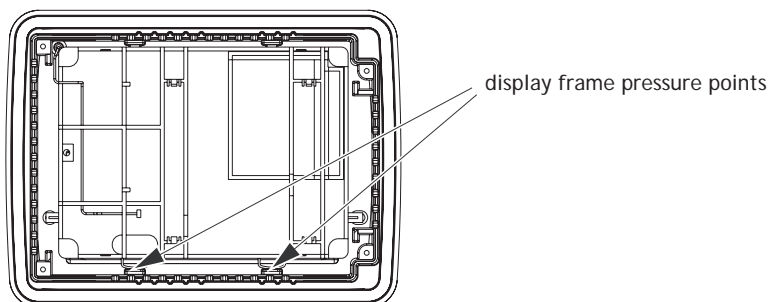
To replace the display you will need a new display including display frame, see the [Available Spare Parts](#) section.

Follow the steps below:

1. Power off the operator panel.
2. Follow the instructions under [Replacing the Rear Cover](#) to remove the rear cover.
3. Unlock the two flex cable connectors by pressing the connector flanges towards the cable and disconnect the flex cables and the plain cable from the power card. The connectors must be unlocked on both sides before removing the cables.
4. Disconnect LED cable, if applicable.



5. Gently press the power card towards the top of the panel as shown in the illustration above to release the power card from the power card holders. Then tilt the bottom of the card away from you.
6. Disconnect the plain cable on the back side of the power card and then remove the power card.
7. Insert the two screwdrivers between the display frame and the aluminum casing illustrated below. Press and bend gently on the display frame to unlock the frame and tilt up the display frame.

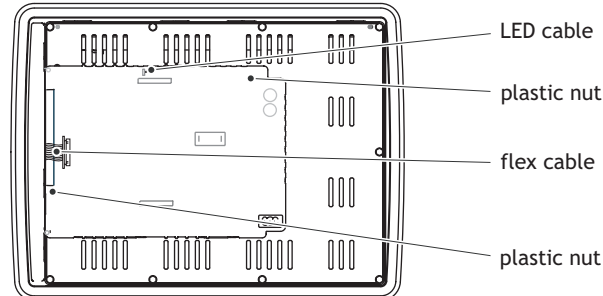


8. Mount the new display unit.
9. Re-assemble the complete operator panel.

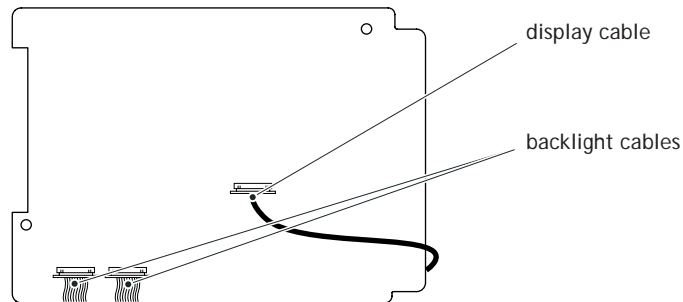
**EXTER T100**

Follow the steps below to replace the display/display cable of EXTER T100:

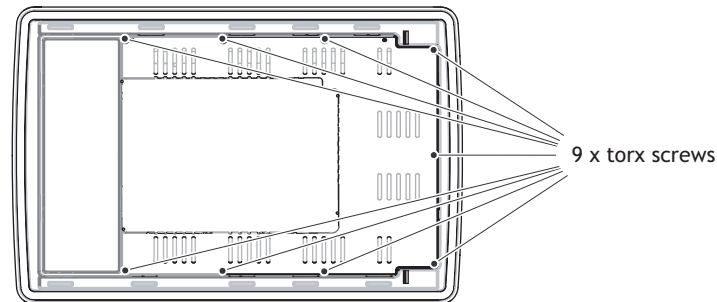
1. Power off the operator panel.
2. Follow the instructions under [Replacing the Rear Cover](#) to remove the rear cover.
3. Disconnect the flex cable and the cable to the LED on the power card and remove the two plastic nuts that keep the power card in place.



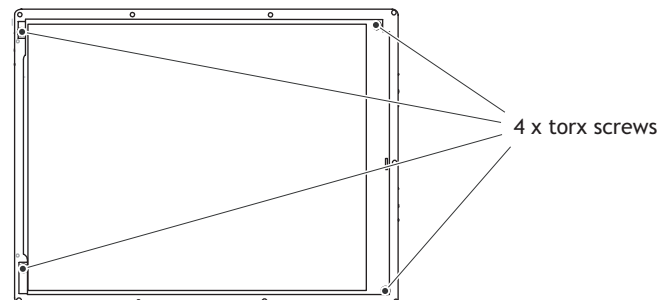
4. Lift up the power card and gently remove the backlight cables and the display cable from the rear side of the power card.



5. Remove the mounting plate (9 torx screws). Gently lift up the mounting plate and the display.



6. Flip the mounting plate and unscrew the 4 torx screws, see figure below.

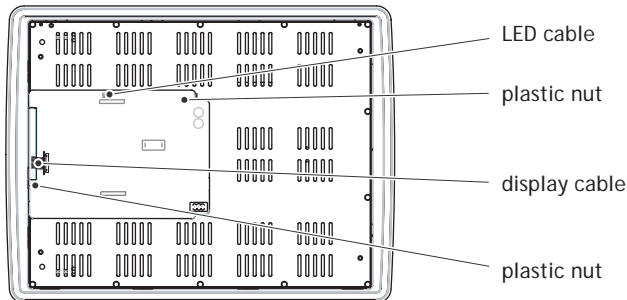


7. Make sure the display cable is attached to the new display before reattaching the mounting plate.
8. Re-assemble the complete operator panel.

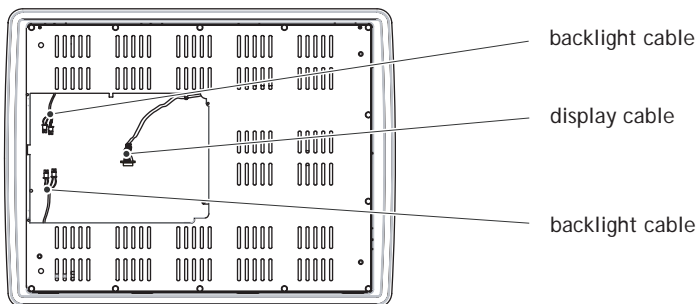
**EXTER T150**

Follow the steps below to replace the display/display cable of EXTER T150:

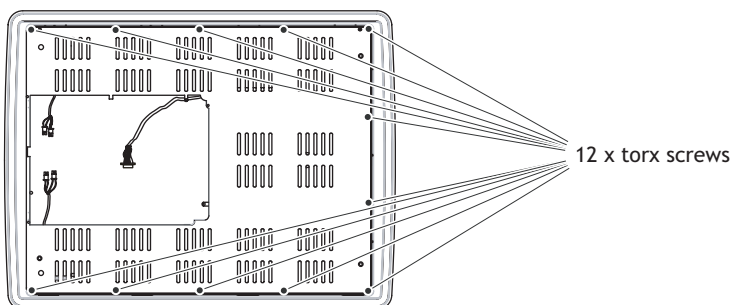
1. Power off the operator panel.
2. Follow the instructions under [Replacing the Rear Cover](#) to remove the rear cover.
3. Disconnect the flex cable and the LED cable from the power card. The connector on the flex cable is a plain connector so just pull the connector out.
4. Remove the two plastic nuts that keep the power card in place.



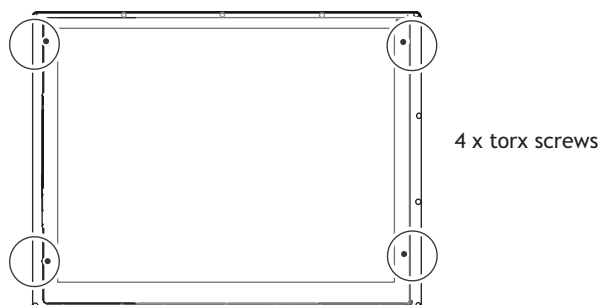
5. Lift up the power card and gently remove the 4 backlight cables and disconnect the display cable from the power card.



6. Remove the mounting plate (12 torx screws).



7. Gently lift up the mounting plate and the display.
8. Flip the mounting plate and unscrew the 4 torx screws, located on front or side.



*Flipped mounting plate display with 4 torx screws*

9. Make sure that the display cable is positioned inside the hollow of the adapter plate, intended for the display, before reattaching the mounting plate.
10. Re-assemble the complete operator panel.

### 3.6.5 Self-test of the Display

To perform a self-test of the display, follow the steps below:

1. Start the operator panel in a self-test mode (see table in the *Mode Switches* section).
2. Go to the display test. Verify that the display works.
3. If the screen does not work, try fault tracing, see the *Fault Tracing* section.

### 3.6.6 Calibrate the Touch Screen

To calibrate the touch screen, follow the steps below:

---

**Note:**

A USB keyboard and a USB mouse must be connected to the operator panel.

---

1. Set the MODE switches to the correct positions in order to enter the Service Menu mode (see table in the *Mode Switches* section).
2. Switch on the power and follow the instructions.
3. Power off the operating panel.
4. Reset all MODE switches to the OFF position.

### 3.6.7 Replacing the Complete Front

The following is needed:

- A new front, see the [Available Spare Parts](#) list.
- A torx T10 screwdriver.

---

**Note:**

Make sure you have adequate ESD protection.

---

**EXTER K10m, EXTER K20m, EXTER K30m, EXTER K60/K60c/  
K60m, EXTER T40/T40m and EXTER T60/T60c/T60m**

Follow the steps below to replace the complete front of the operator panel:

1. Power off the operator panel.
2. Follow the steps 1-6 in the [Replacing the Display/Display Cable](#) instructions for the current panel model.
3. Attach the new front.
4. Re-assemble the unit.

**EXTER K70 and EXTER T70**

Follow the steps below to replace the complete front of EXTER K70/EXTER T70:

1. Power off the operator panel.
2. Follow the steps 1-3 and step 5 in the [Replacing the Display/Display Cable](#) instruction for EXTER K70/EXTER T70, but in step 3, do not remove the display cable.
3. Attach the new front.
4. Re-assemble the unit.

**EXTER K100**

Follow the steps below to replace the complete front of EXTER K100:

1. Power off the operator panel.
2. Follow the steps 1-3 and step 5 in the [Replacing the Display/Display Cable](#) instruction for EXTER K100, but in step 3, only disconnect the flex cable (do not remove the power card).
3. Attach the new front.
4. Re-assemble the unit.

**EXTER T100**

Follow the steps below to replace the complete front of EXTER T100:

1. Power off the operator panel.
2. Follow the steps 1-3 and 5 in the [Replacing the Display/Display Cable](#) instruction for EXTER T100, but in step 3, only disconnect the flex cables and the LED cable (do not remove the power card).
3. Attach the new front.
4. Re-assemble the unit.

**EXTER T150**

Follow the steps below to replace the complete front of EXTER T150:

1. Power off the operator panel.
2. Follow the steps 1-3 and step 5 in the [Replacing the Display/Display Cable](#) instruction for EXTER T150, but in step 3, only disconnect the flex cable and the LED cable (do not remove the power card).
3. Attach the new front.
4. Re-assemble the unit.

### 3.6.8 Replacing the Battery

---

**Note:**

Make sure you have adequate ESD protection.

---

**Note:**

Make sure to make a backup copy of the operator panel project.

---

**EXTER K10m and EXTER K20m**

These operator panels use a rechargeable battery.

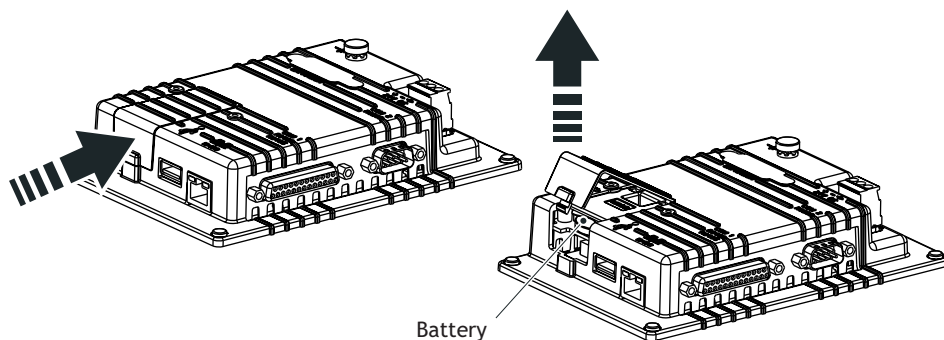
**EXTER K30m, EXTER K60/K60c/K60m, EXTER T40/T40m and EXTER T60/T60c/T60m**

The following is needed:

- A new battery, see the [Available Spare Parts](#) list.

Follow the steps below to replace the battery:

1. Power off the operator panel.
2. Open the battery cover.
3. Use a non-conductive pair of pliers to extract the battery



4. Insert the new battery.
5. Re-assemble the battery cover.

---

**Note:**

The removed lithium battery should be recycled.

---



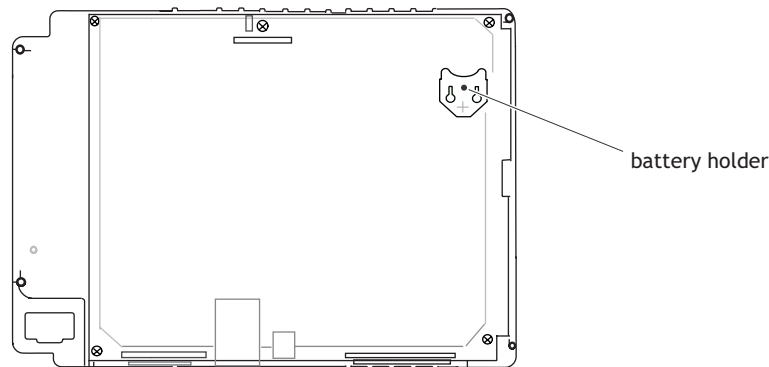
**EXTER K70, EXTER K100, EXTER T70, EXTER T100 and EXTER T150**

The following is needed:

- A new battery, see the [Available Spare Parts](#) list.
- Glue Gun: Jet-Melt TCQ, manufacturer: 3M
- Melting Glue: 3748 V-O, manufacturer: 3M

Follow the steps below to replace the battery:

1. Power off the operator panel.
2. Follow the instructions under [Replacing the Rear Cover](#) to remove the rear cover.
3. Flip the back cover (the CPU board and the battery are mounted on the rear side of the back cover).



*CPU board with battery holder on the rear side of the back cover*

4. If the battery is glued with melting glue, remove the glue before carefully removing the battery from the battery holder.
5. Carefully fit the new battery into the battery holder. Make sure the plus sign on the battery is set towards the plus sign on the holder.
6. Glue the battery to the battery holder with melting glue.
7. Re-assemble the operator panel in reverse order.

---

**Note:**

The removed lithium battery should be recycled.

---

### 3.6.9 Replacing the Backlight

---

**Note:**

All lamps in the display must be replaced at the same time.

---

To following is needed:

- A new backlight, see the [Available Spare Parts](#) list.
  - A torx T10 screwdriver
  - A screwdriver Phillips size 0 or 00 (only for EXTER T150).
- 

**Note:**

Make sure you have adequate ESD protection.

---

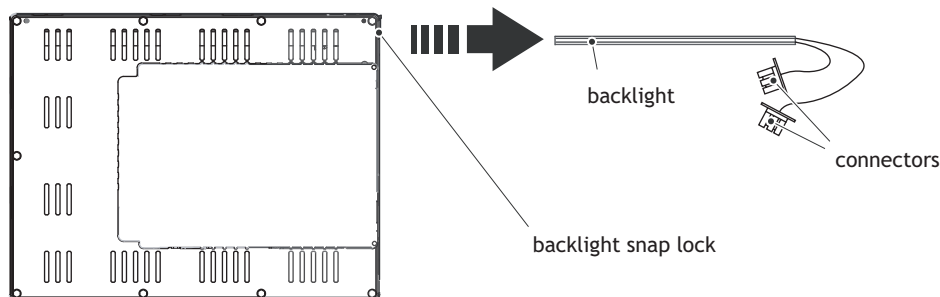
**EXTER K10m, EXTER K20m, EXTER K30m, EXTER K60/K60c/K60m, EXTER K70, EXTER T40/T40m, EXTER T60/T60c/T60m and EXTER T70**

If the backlight is broken on a panel listed above, the entire display must be replaced. To replace the display you will need a new display including plastic frame and display cable, see the [Available Spare Parts](#) section. For information about changing the display, see [Replacing the Display/Display Cable](#) section.

#### EXTER K100

To replace the backlight of EXTER K100, follow the steps 1-5 in section [Replacing the Rear Cover](#) for EXTER K100. Then follow the steps below:

1. Gently move the backlight diagonally in direction from the display center to release the snap-in closure that keeps the backlight in place.
2. Remove the backlight from the display.



3. Insert the new backlight. Be careful not to pull the cables of the new backlight when inserting it, since pulling the cables will damage the backlight.
4. Re-assemble the complete operator panel.

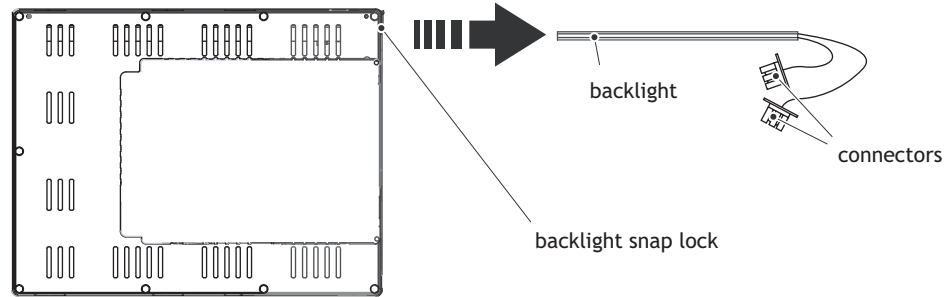
#### EXTER T100

If the backlight of EXTER T100sr is broken, the entire display must be replaced. To replace the display you will need a new display including plastic frame and display cable, see the [Available Spare Parts](#) section. For information about changing the display, see [Replacing the Display/Display Cable](#) section.

To replace the backlight of EXTER T100, follow the steps 1-5 in section [Replacing the Rear Cover](#) for EXTER T100. Then follow the steps below:

1. Gently move the backlight diagonally in direction from the display center to release the snap-in closure that keeps the backlight in place.

2. Remove the backlight from the display.



3. Insert the new backlight. Be careful not to pull the cables of the new backlight when inserting it, since pulling the cables will damage the backlight.
4. Re-assemble the complete operator panel.

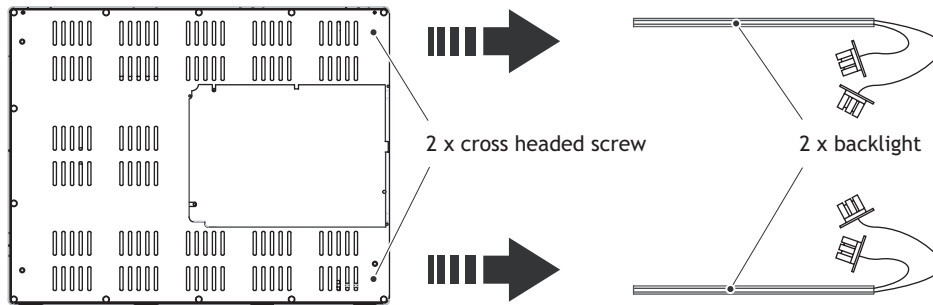
## EXTER T150

If the backlight of EXTER T150sr is broken, the entire display must be replaced. To replace the display you will need a new display including plastic frame and display cable, see the [Available Spare Parts](#) section. For information about changing the display See [Replacing the Display/Display Cable](#) section.

To replace the backlight of EXTER T150 you will need two new backlights, see the [Available Spare Parts](#) list.

Follow the steps 1-5 in section [Replacing the Rear Cover](#) for EXTER T150. Then follow the steps below:

1. Remove the two cross-headed screws to the backlight, using the Phillips size 00 screwdriver. This way, backlights can be removed without removing the plate.



2. Remove the backlights.
3. Insert the new backlights. Be careful not to pull the cables of the new backlights when inserting them, since pulling the cables will damage the backlights.
4. Re-assemble the complete operator panel.

### 3.6.10 Available Spare Parts

The table below lists available spare parts:

Order number	Description - Fronts	Operator Panel
601119007	COMPLETE FRONT Including front cover, glass, keyboard, gaskets and labels	EXTER K10m
601119008	COMPLETE FRONT Including front cover, glass, keyboard, gaskets and labels	EXTER K20m
601009084	COMPLETE FRONT Including front cover, glass, keyboard, gaskets and labels	EXTER K30m
601009088	COMPLETE FRONT Including front cover, touch overlay, gaskets and labels	EXTER T40/T40m
601009086	COMPLETE FRONT Including front cover, glass, keyboard, gaskets and labels	EXTER K60/K60c/K60m
601009113	COMPLETE FRONT Including front cover, touch overlay, gaskets and labels	EXTER T60/T60c/T60m
601009018	COMPLETE FRONT Including front cover, glass, keyboard, gaskets and labels	EXTER K70
601009016	COMPLETE FRONT Including front cover, touch overlay, gaskets and labels	EXTER T70
601119034	COMPLETE FRONT Including front cover, touch overlay, gaskets and labels	EXTER T70sr
601009033	COMPLETE FRONT Including front cover, glass, keyboard, gaskets and labels	EXTER K100
601009031	COMPLETE FRONT Including front cover, touch overlay, gaskets and labels	EXTER T100
601119035	COMPLETE FRONT Including front cover, touch overlay, gaskets and labels	EXTER T100sr
601009044	COMPLETE FRONT Including front cover, touch overlay, gaskets and labels	EXTER T150
601119036	COMPLETE FRONT Including front cover, touch overlay, gaskets and labels	EXTER T150sr

Order number	Description - Displays	Operator Panel
601009156	DISPLAY Including frame and cable	EXTER K10m
601009157	DISPLAY Including frame and cable	EXTER K20m
601009064	DISPLAY Including frame and cable	EXTER K30m
601009065	DISPLAY Including frame and cable	EXTER T40/T40m

Order number	Description - Displays	Operator Panel
601009067	DISPLAY Including frame and cable	EXTER K60c and EXTER T60c
601119029	DISPLAY Including frame and cable	EXTER K60/K60m and EXTER T60/T60m*
601009066	DISPLAY Including frame and cable	EXTER T60m**
601009014	DISPLAY Including frame and cable	EXTER K70 and EXTER T70
601119037	DISPLAY Including frame and cable	EXTER T70sr
601009027	DISPLAY Including frame and cable	EXTER K100 and EXTER T100
601119038	DISPLAY Including frame and cable	EXTER T100sr
601009041	DISPLAY Including frame and cable	EXTER T150
601119046	DISPLAY Including frame and cable	EXTER T150sr

\*applies to EXTER T60m of hardware version type no 07600 or higher

\*\*applies to EXTER T60m of hardware version type no 06674 or lower

Order number	Description - Backlights, Display Cables	Operator Panel
N/A	BACKLIGHT Is not replaceable. Change complete display.	EXTER K10m, EXTER K20m, EXTER K30m, EXTER K60/K60c/K60m, EXTER K70, EXTER T40/T40m, EXTER T60/T60c/T60m and EXTER T70
601009050	BACKLIGHT	EXTER K100 and EXTER T100
601009049	BACKLIGHT (Includes two pieces, top and bottom)	EXTER T150
601009015	DISPLAY CABLE	EXTER K70 and EXTER T70
601119047	DISPLAY CABLE	EXTER T70sr
601009028	DISPLAY CABLE	EXTER K100 and EXTER T100
601009042	DISPLAY CABLE	EXTER T150

Order number	Description - Power supply	Operator Panel
321099040	POWER CONNECTOR	All operator panels in the EXTER-series
601009010	BATTERY, Lithium battery 550mAh CR2450	All operator panels in the EXTER-series

Order number	Description - Covers	Operator Panel
601119011	REAR COVER	EXTER K10m and EXTER K20m
601009120	REAR COVER	EXTER K30m
601009121	REAR COVER	EXTER T40/T40m
601009122	REAR COVER	EXTER K60/K60c/K60m, EXTER T60/T60c/T60m
601009011	REAR COVER	EXTER K70, EXTER K100, EXTER T70, EXTER T100 and EXTER T150
601009123	BATTERY COVER	EXTER K30m, EXTER K60/K60c/K60m, EXTER T40/T40m, EXTER T60/T60c/T60m
601009003	CF COVER	EXTER K70, EXTER K100, EXTER T70, EXTER T100 and EXTER T150
601009001	MOUNTING BRACKETS Bracket with mounted M5-screw	All operator panels in the EXTER-series

Order number	Description - Touch and key protections	Operator Panel
N/A	KEY PROTECTION SHEET	EXTER K10m
N/A	KEY PROTECTION SHEET	EXTER K20m
601009080	KEY PROTECTION SHEET	EXTER K30m
601009081	TOUCH PROTECTION SHEET	EXTER T40/T40m
601009083	KEY PROTECTION SHEET	EXTER K60/K60c/K60m
601009082	TOUCH PROTECTION SHEET	EXTER T60/T60c/T60m
601009055	KEY PROTECTION SHEET	EXTER K70
601009024	TOUCH PROTECTION SHEET	EXTER T70
601009056	KEY PROTECTION SHEET	EXTER K100

Order number	Description - Touch and key protections	Operator Panel
601009039	TOUCH PROTECTION SHEET	EXTER T100
601009048	TOUCH PROTECTION SHEET	EXTER T150

Order number	Description - Labels	Operator Panel
601009124	LABEL (for expansion port)	EXTER K30m, EXTER K60/K60c/K60m, EXTER T40/T40m and EXTER T60/T60c/T60m

Order number	Description - Packing	Operator Panel
601009211	COMPLETE BOX	EXTER K10m
601009212	COMPLETE BOX	EXTER K20m
601009125	COMPLETE BOX	EXTER K30m
601009126	COMPLETE BOX	EXTER T40/T40m
601009128	COMPLETE BOX	EXTER K60/K60c/K60m
601009127	COMPLETE BOX	EXTER T60/T60c/T60m
601009122	COMPLETE BOX	EXTER K70
601009120	COMPLETE BOX	EXTER T70
601009137	COMPLETE BOX	EXTER K100
601009135	COMPLETE BOX	EXTER T100
601009146	COMPLETE BOX	EXTER T150

Order number	Description - Test service items	Operator Panel
601009008	TEST PLUG ETHERNET Ethernet RJ45 test connector	All operator panels in the EXTER-series
601009006	TEST PLUG RS232 RS232 test connector	All operator panels in the EXTER-series
601009007	TEST PLUG RS422/485 RS422/485 test connector	All operator panels in the EXTER-series
601009004	TEST PLUG USB H-D USB Host and Device test connector	EXTER K70, EXTER K100, EXTER T70, EXTER T100 and EXTER T150
601009069	TEST PLUG USB H USB Host test connector	All operator panels in the EXTER-series



## 3.7 Service Menu

The Service Menu is accessed by setting the mode switches on the operator panel in mode 1000.

The following options are available in the Service Menu:

### 3.7.1 Network Settings

Select this option to access the Network Menu.

#### Network Menu

The options in the Network Menu corresponds to selecting **Settings/Network** in Information Designer and contains the following items:

Menu item	Described in Information Designer reference manual/help file
TCP/IP Settings	Network Communication through Ethernet
Accounts	Network Accounts
Services	Network Services

### 3.7.2 Erase Project Memory

This option erases the project memory.

### 3.7.3 Load Project from Memory Card

An empty operator panel can be started with an existing Information Designer project, used in another panel. The project first has to be saved to a Compact Flash memory card or USB memory stick via the function **Save project to memory card** (for example via a function key).

Insert the memory card in the empty panel before boot-up. Then select **Load project from memory card** in the service menu and follow the instructions.

### 3.7.4 Enter Transfer Mode

Allows entering transfer mode manually, needed to download projects via GSM modem. See section **Transfer via GSM Modem** in Information Designer reference manual/help file for details.

### 3.7.5 Enter Run Mode

Allows entering run mode manually, needed to download projects via GSM modem. See section **Transfer via GSM Modem** in Information Designer reference manual/help file for details.

### 3.7.6 Update System Program from Memory Card

Insert a Compact Flash or USB memory stick with a new system program and follow the instructions. The system program can also be updated via the configuration tool for the operator panels.

### 3.7.7 Calibrate Touch Screen

Follow the instructions on the screen to calibrate the touch screen.

## 3.8 Hardware Self Test

The self-test program can be used to test aspects of operator panel functionality and the communication ports. To run the test you will need:

- Test plugs; see [Test Plug Drawing](#).
- 24 V DC, min. 3 A.

Follow the steps below to run the self-test program on the operator panel:

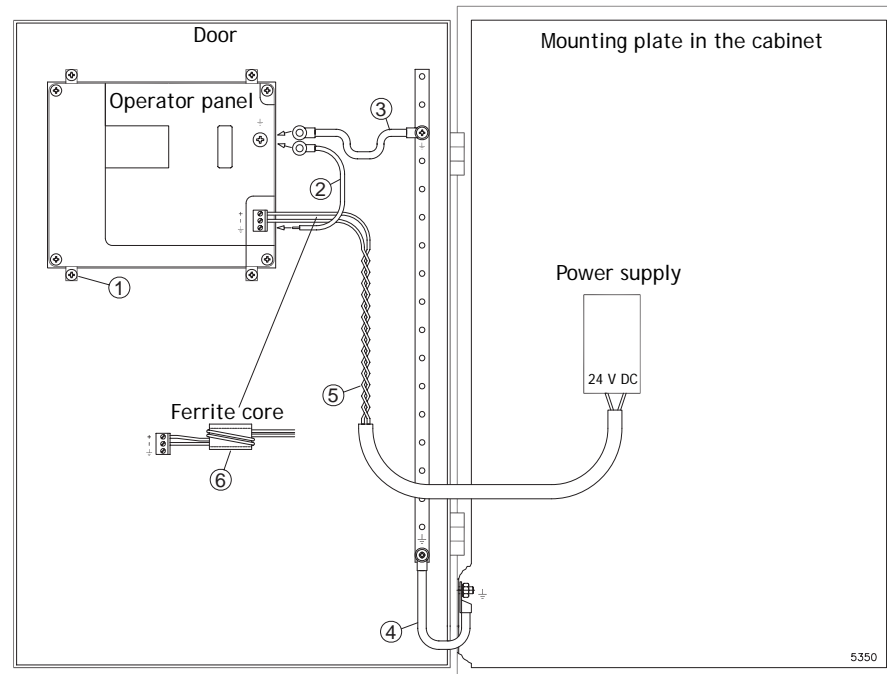
1. Power off the operator panel.
2. Go to the self-test. Set the mode switches to the self-test positions, see the table in the [Mode Switches](#) section.
3. Power on the operator panel and follow the instructions at the bottom of the display.
4. When using the test plugs, make sure all LEDs on the 9-pin and 25-pin D-sub are on.
5. When the self-test is finished, power off the operator panel and set all mode switches to the OFF position.

If an error occurs during the self-test, try to fault trace. See [Fault Tracing](#).

## 3.9 Additional Installation Tips

When experiencing communication problems in for example noisy environments or when operating close to temperature limits, the following recommendations are to be noticed.

### 3.9.1 Grounding the Operator Panel



1. The operator panel's mounting clamps do not provide a secure grounding connection between the panel and the device cabinet.
2. Connect a 2.5 mm<sup>2</sup> wire between the operator panel's quick-connect plinth and the panel chassis.
3. Connect a 6 or 4 mm<sup>2</sup> wire or grounding braid between the panel's chassis and the closest grounding point on the door.
4. Connect a strong but short grounding braid between the door and the device cabinet.
5. Twist the cables onto the 24 V DC feed.
6. A ferrite core suppresses disturbances to the 24 V feed.
  - 2 turns around the ferrite core provide 4 times the suppression of 1 turn.
  - 3 turns around the ferrite core provide 9 times the suppression of 1 turn.

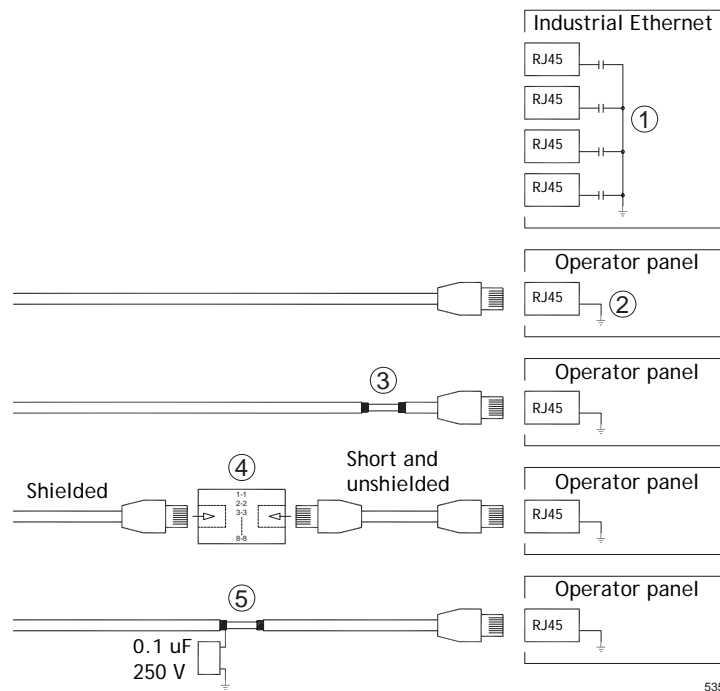
---

**Remember:**

The grounding wires should be short and the conductor should have a large area. A long, thin grounding wire has a very high impedance (resistance) at high frequencies and will not guide disturbances to the ground. Multi-wire conductors are better than single wire conductors with the same area. A braided conductor wire with the same area is even better. The best is a short, thick grounding braid.

---

### 3.9.2 Ethernet Connection in the Panel



1. In some industrial units for Ethernet, the RJ45 contact's shield is connected to the chassis via a capacitor.
2. The operator panel's Ethernet shield is directly connected to the chassis.

Check whether the other Ethernet unit has its shield directly grounded or grounded via a capacitor.

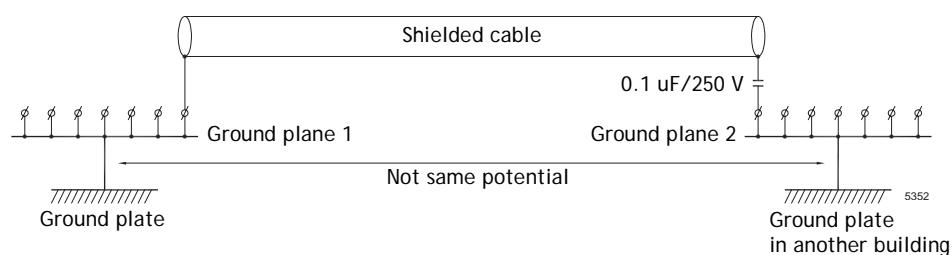
In many cases, connecting the shielded Ethernet cabling to the chassis at both ends is inappropriate. Hum or grounding loops can occur. Unshielded cabling may even result in fewer communication errors.

A good solution may be to use a shielded Ethernet cable, but to connect the shield at one end only.

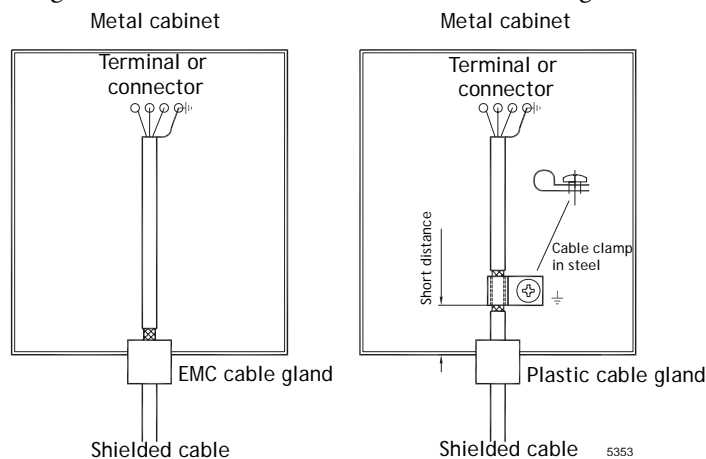
3. One option is to break the shield.
4. A more elegant method is to expand the shielded Ethernet cabling with a piece of unshielded Ethernet cable.
5. You can ground the shield via an external 0.1 uF/250 V plastic capacitor. This will connect the HF transients to the ground.

### 3.9.3 To Achieve Better EMC Protection

- Initially, use the original cabling from Beijer Electronics primarily.
- Use shielded cables for RS232 communication.
- Use twisted pair and shielded cabling for RS422 and RS485.
- Use the cabling intended for the bus type; Ethernet, Profibus, CC-Link, CAN, Device Net etc.
- Install and connect according to applicable specifications for the relevant bus standard.
- Use shielded cabling for Ethernet, preferably with foil + braided shield.
- D-sub covers should be shielded, and the shield should be connected to the cover 360 ° where the cable comes in.
- Connect the shield at both ends.



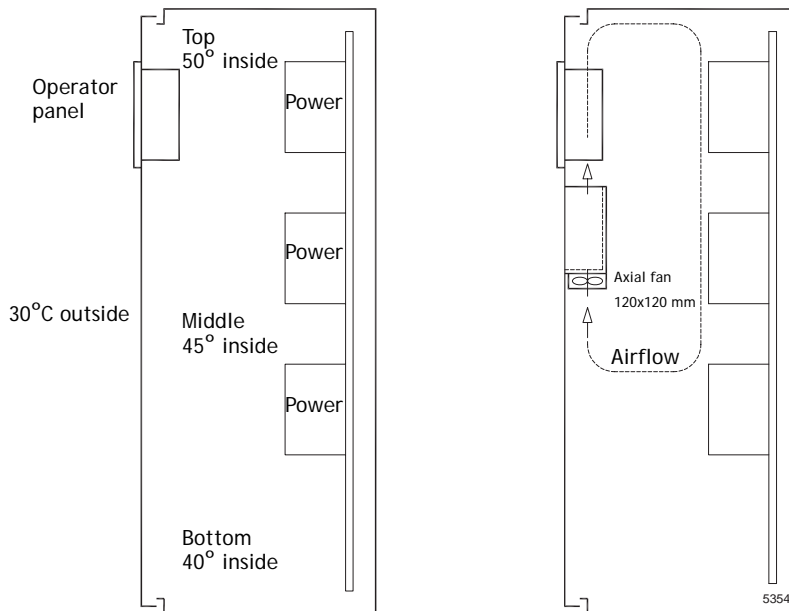
With longer distances, there is a risk that the ground potential may be different. In that case, the shield should only be connected at one end. A good alternative is to connect the other end of the shield to the ground via a 0.1 uF/250 V plastic capacitor. Both ends are then connected to the ground in terms of HF, but only connected to the ground at one end in terms of LF, thus avoiding the 50 Hz grounding loops.



- Use an EMC cable gland or regular plastic cable gland, remove the outer jacket and connect the shield to the installation plate with a 360 ° metal cable clamp.
- Place the 24 V DC and communications cabling in one cable trunk/cable duct and 230/380 V AC in another. If the cables need to be crossed, cross them at 90 ° only. Avoid combining the cabling for stronger 24 V DC outputs with the communication cabling.
- Ferrite cores that are snapped onto the shielded cabling may remove minor disturbances. Large ferrite pieces that are snapped onto unshielded cabling and where the wires go 2-4 times around the cores are approximately 5-25 times more efficient.

### 3.9.4 Ambient Temperature

The maximum ambient temperature for the operator panel is provided in the specifications. The ambient temperature refers to the temperature in the device cabinet which cools the panel's electronics.



In most cases, the ambient temperature for the operator panel is significantly higher than the device cabinet's ambient temperature.

If the cabinet is tall and there are a number of heat-generating devices, the temperature at the top of the cabinet will be considerably higher than the theoretical temperature increase that would be expected. All electronics are sensitive to heat. The lifespan of an electrolytic capacitor is cut in half with an 8-10 ° increase in temperature. A 15-20 ° temperature increase results in a quarter of the lifespan etc.

Rittal has a good program for estimating the anticipated average temperature in the cabinet as well as a large program for controlling the temperature in the device cabinet.

An enamel-coated steel cabinet has a radiant heat value of  $5.5 \text{ W/m}^2$  and degrees C.

Installing a fan inside the cabinet will even out the temperature, while moving air provides considerably better cooling than still air. A suitable fan is a 120 x 120 mm axial fan, available in 24 V DC, 115 and 230 V AC.

Install the fan so that it sits in the cooler area and will blow cold air against the operator panel. If the fan is mounted at the top and sucks air upwards, the fan's ambient temperature will be higher = shorter lifespan.

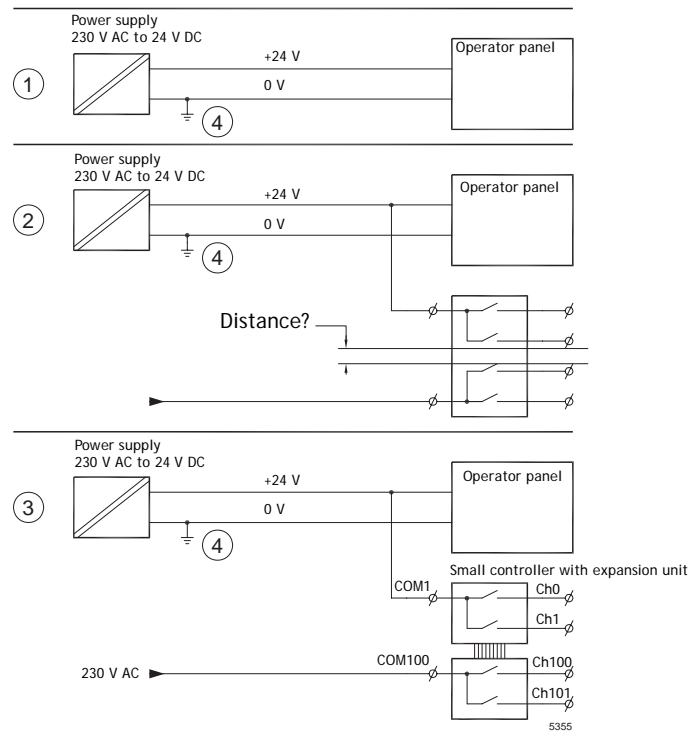
A good fan with a ball-bearing mounting has an expected lifespan of at least 40,000 hours (not a guaranteed lifespan) at 40 °C. This corresponds to at least 4 years of continuous use. If a thermostat is installed, the fan only needs to come on when needed.

Large graphic terminals draw only one fifth of the current when the background lighting is off. The loss effect drops from e.g. 25 W to only 5 W.

The operator panel's loss effect = supply voltage x current. Virtually no power goes to external users and no loss effects due to inputs.

### 3.9.5 Safety

Most of the operator panels are fed with 24 V DC.



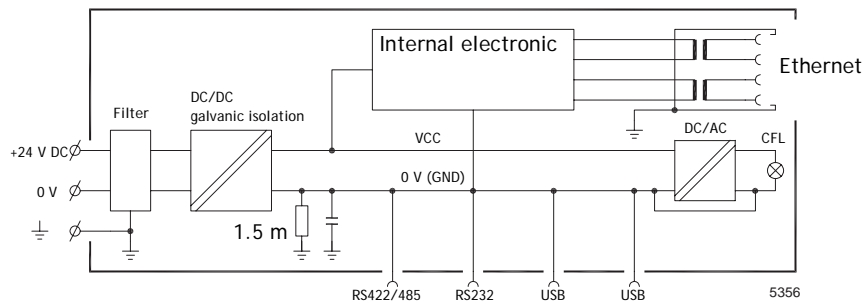
6. If you use a power supply that meets safety standards and only feeds the operator panel, there is no problem.
7. However, if you have a 24 V unit that also feeds other units, there is reason to be cautious.  
The operator panel does not have insulation that meets safety requirements in the event of a potential short circuit between 230 V AC and 24 V DC. It is assumed that the 24 V feed is secure, for example, SELV according to EN 60950 (protection against electric shock) and UL 950.

#### Example:

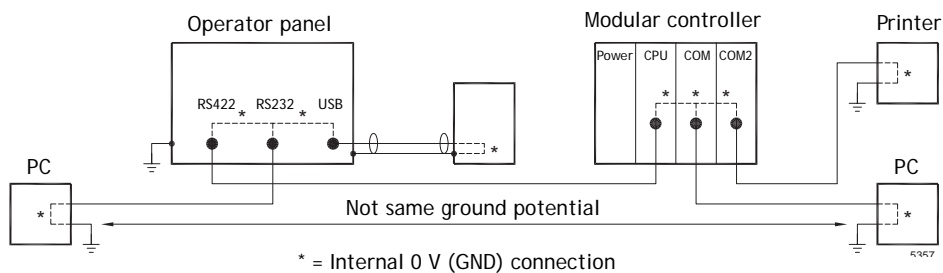
Here is an example that explains why a secure 24 V DC feed can be ruined by mixing 24 V relay contacts with 230 V AC relay contacts in a smaller controller. Check that the "clearances and creepage distances between 24 V DC and 230 V AC fulfill EN 60950 or UL 950". If not, input a separate 24 V unit into the operator panel.

8. If there is a substantial distance between the relay contacts for 24 V DC and 230 V AC, it is OK to use the same 24 V devices for all feeds.
9. Connect 0 V on the 24 V feed to the ground. This offers three advantages:
  - Safety is increased. The 24 V feed will not be live in the event of a faulty connection or short circuit between 0 V (24 V) and 230 V phase.
  - Transients on the 24 V feed are connected to the ground.
  - No risk that the 24 V feed is at a high level in relationship to the ground. This is not unusual since there is high static electricity.

### 3.9.6 Galvanic Isolation



The operator panel has galvanic isolation against the 24 V DC feed but no galvanic isolation between the panel and the communication ports for RS232, RS422/485 and USB. Only the Ethernet connection has galvanic isolation.



When a PC is connected to the panel, the panel's internal 0 V (GND) will be connected to the protective ground via the PC.

A number of USB devices can have the shield connected together with the protective ground. Here, the panel's 0 V (GND) is connected to the protective ground when, for example, a USB memory stick, keyboard or similar device is plugged in.

If a number of units are connected that have a 0 V and a ground connection, and these are connected to various grounding points, there is a substantial risk of problems. Grounding currents go through communication cables, the rear plate of the controller, and internally in the operator panel, and can cause errors.

Use external units to improve communication and achieve galvanic isolation.

Westermo has good industry-standard insulators that are also insulated from the 24 V DC feed.

---

#### Note:

It is very important to make sure that the 24 V feed in the external insulation unit is not connected to one of the communication outlets. If it does not have 100% insulation against the 24 V feed, disturbances and grounding currents from the 0 V on the 24 V side will disrupt communication.

Using this type of unit solves one problem but creates a larger problem!

A substandard installation may work now, but problems may arise when other devices are connected.

---



### 3.9.7 Cable and Bus Termination RS485

- Use shielded and twisted pair cable.

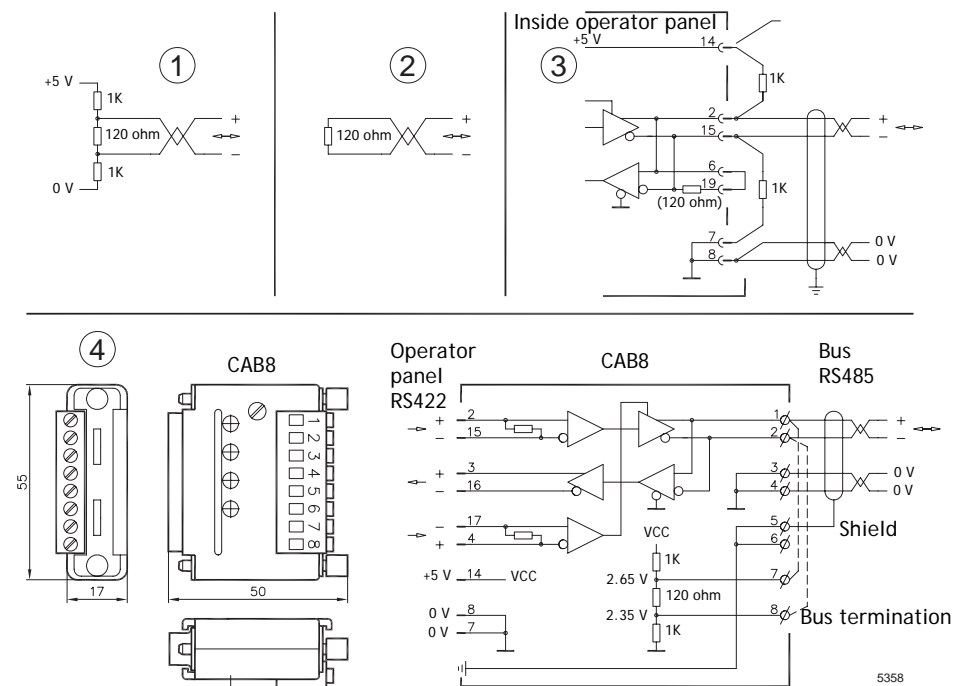
The pair capacitance may not exceed 52.5 pF/m and area at least 0.25 mm<sup>2</sup> (AWG 24), if you want to use the maximum transfer distance and maximum transfer speed.

- 0 V, the reference voltage for communication should be included in the cabling. With two-way communication use two pairs; one pair for communication and one pair for 0 V.
- The shield must be grounded at one end. The other end is usually grounded, but with longer distances or when there is a difference in the ground potential, the shield should be connected to the ground via 0.1 uF/250 V plastic capacitor to prevent ground current in the braided shield.

A number of manufacturers recommend that the shield be grounded at each node.

Various manufacturers have different systems for bus termination. The RS485 standard does not describe how the “Fail Safe” function would be carried out, just that the system should be be able to handle the error.

Depending on the recipients’ design, the bus wires may be on the same level or require pull-up or pull-down to ensure that no faulty signals are detected when the bus is in resting mode (all transmitters are disconnected).



1. Some (older) operator panels had pull-up and pull-down resistance except for the actual bus termination at 120 ohm, similar to Westermo and Profibus.
2. Newer panels have another type of recipient, so-called built-in “Fail Safe”, where simple bus termination resistance is sufficient.

If other nodes on the RS485 network require pull-up and pull-down and the operator panel is at one end of the loop, one of the following procedures can be carried out:

3. Connect two 1k/0.25 W resistors in the 25-pole D-sub contact. Set jumper pins 6-19.
4. Use CAB8. It offers the option of bus termination with pull-up/-down. It is also easy to connect the bus cable via the screw terminal block.

## 3.10 Fault Tracing

You can use the following fault tracing list to fault trace the operator panel. The table below consists of different fault scenarios and steps to follow to trace the fault

Scenario	Fault tracing steps
The operator panel is not working properly. Power LED is off.	<ol style="list-style-type: none"> <li>1. Is the power voltage correct?</li> <li>2. Does the power supply deliver enough current?</li> <li>3. Check the fuse.</li> <li>4. Check the power card.</li> <li>5. Is the power card correctly mounted?</li> </ol>
The operator panel is not communicating with the controller.	<ol style="list-style-type: none"> <li>1. Check the communication cable between the units.</li> <li>2. Check that the operator panel has a controller driver downloaded.</li> <li>3. Check that the correct controller driver is used.</li> <li>4. Check the communication ports on the CPU board.</li> </ol>
The operator panel is working but the backlight is off.	<ol style="list-style-type: none"> <li>1. Check the backlight dimming.</li> <li>2. Check that the backlight is connected to the power card.</li> <li>3. Replace the backlight according to the <a href="#">Replacing the Backlight</a> section.</li> <li>4. Check the DC/AC on the power card.</li> </ol>
The operator panel is not working, the backlight is off but the power LED is on.	<ol style="list-style-type: none"> <li>1. Check the backlight dimming.</li> <li>2. Check the CPU board for burned components.</li> <li>3. Download new firmware to the operator panel.</li> </ol>
The operator panel does not include the latest firmware.	<ol style="list-style-type: none"> <li>1. Check the versions included with the operator panel.</li> <li>2. Make sure that a copy of the project is saved to the computer.</li> <li>3. Download an updated image with the Image Loader and follow the directions.</li> </ol>
The operator panel is working, but one or more keys are not working.	<ol style="list-style-type: none"> <li>1. Check that the flex cables are correctly fitted.</li> <li>2. Replace the front according to the <a href="#">Replacing the Rear Cover</a> section.</li> </ol>
The touch screen is malfunctioning or is not responding at all.	<ol style="list-style-type: none"> <li>1. Re-calibrate the touch screen according to the <a href="#">Calibrate the Touch Screen</a> section.</li> <li>2. Check that the flex cable is correctly fitted.</li> <li>3. Replace the display of the operator panel according to the <a href="#">Replacing the Display/Display Cable</a> section.</li> <li>4. Check the touch interface on the power card.</li> </ol>
Lines in display has wrong color or the display picture is shifted.	<ol style="list-style-type: none"> <li>1. Check if the display has a wide vertical or horizontal area across the display. It should be at least 2-3 cm wide with a grey or black color. See <a href="#">Replacing the Rear Cover</a> for instructions on how to correct this.</li> <li>2. Make sure the display cable is correctly fitted.</li> <li>3. Make sure the display cable is not folded or damaged in any way. Replace the display cable according to the <a href="#">Replacing the Display/Display Cable</a> section.</li> </ol>
The operator panel will not restart after changing a component.	<ol style="list-style-type: none"> <li>1. Remove and insert the battery again. (This is only valid for panels with an external battery cover.)</li> </ol>
Low battery/ No battery	<ol style="list-style-type: none"> <li>1. Check that the battery is correctly fitted in its holder.</li> <li>2. If low battery/no battery voltage, replace the battery according to the <a href="#">Replacing the Battery</a> section.</li> </ol>

## 4 Software

This chapter describes how to maintain and update the software in the EXTER operator panels. The chapter includes a general description of the operator panel software and instructions about how to upgrade the software and load projects and system programs.

### 4.1 General Information about Software

The software required to run and maintain the operator panels is found on the software CD. It is also available through your local distributor.

The software is tested by the manufacturer's own testing department before market introduction is approved. The test procedure is closely integrated with the development process. The test group works in close concert with the developers and is ISEB Certified for Software Testing.

#### 4.1.1 Software Products

The following software products are used:

– *Information Designer*

Information Designer is used for creating application projects for EXTER operator panels and their accessories.

– *Remote Access Viewer*

Remote Access Viewer is a program for remote access and control of EXTER operator panels.

It is possible to access, reflect and control an EXTER operator panel from a PC using the VNC client program Remote Access Viewer (freeware) together with the built-in VNC server (Remote Access function) in the operator panel.

– *System Program*

The operator panel is delivered with a system program (operating system) pre-stored in the operator panel memory.

The configuration tool Information Designer is used to download system programs to the operator panel.

– *Image Loader*

The firmware (the software in the operator panel) for EXTER K30m, EXTER K60/K60c/K60m, EXTER K70, EXTER K100, EXTER T40/T40m, EXTER T60/T60c/T60m, EXTER T70, EXTER T100 and EXTER T150 consists of three parts at delivery:

1. E-Boot, the program that starts up the operator panel and Windows CE.
2. Windows CE .net 4.20, the operating system for the operator panel.
3. OPhys, the system program in the operator panel that contains the HMI functionality.

EXTER K10m and EXTER K20m use the Green Hills Velocity.

Information Designer can be used to update one part of the firmware, the system program OPhys\_b\*.cab, to the operator panel.

See the *System Program* section.

## 4.2 Update Software

When an update is available, an e-mail is sent to the distributors. The software is also available on the manufacturer's web site.

The update should be installed by qualified personnel. When updating an operator panel it is important to ensure that the power is not interrupted during the transfer.

### 4.2.1 Information Designer

Information Designer is not a freeware product. A demo version can be found on the web site. To update this software, an accredited EXTER operator panel dealer must be contacted.

### 4.2.2 Remote Access Viewer

To update this program, go to [www.beijerelectronics.com](http://www.beijerelectronics.com) and select **Support/Downloads/** in the menu. Browse the software folder to locate Remote Access Viewer. Run the .exe file and follow the instructions.

### 4.2.3 Image Loader

An upgrade of the complete software package is sometimes needed to take advantage of new functionality. The complete software package consists of the EBOOT, the Windows CE operating system and the system program. The upgrade is done by running the Image Loader executable file, Bxxx\_uml.exe. The Image Loader application will help and guide you through the upgrade.

When the upgrade is finished, the operator panel will receive the default IP address 192.168.1.1. Follow the instructions on the screen after startup to change the IP address.

The "Update Operator Terminal System Program" function in Information Designer shall not be used when the Image Loader application is used to upgrade the operator panel.

---

**Note:**

ALL existing data, including the file system and the project application files, in the operator panel will be deleted (overwritten) by the Image Loader application

---

**Note:**

The Image Loader software is only intended for customers and partners that have an operator panel. No other distribution is allowed.

---

For EXTER K10m and EXTER K20m, see section [Downloading the System Program in EXTER K10m and EXTER K20m](#).

## 4.2.4 System Program

The system program can be replaced, that is, updated to a newer version, in one of two ways: *Via PC* or *Via External Memory Card*. Not available for EXTER K10m and EXTER K20m. See section *Downloading the System Program in EXTER K10m and EXTER K20m* for these models.

### Via PC

The configuration tool *Information Designer* is used to download system programs via a PC to the operator panel. The transfer can be made via the serial port or over Ethernet. The serial cable should be a CAB30 cable and the Ethernet cable should be a crossed CAT5 cable.

Transferring the system program to the operator panel via a PC requires the following:

- PC with the configuration tool installed.
- Transfer cable between the PC and the operator panel.
- File with new system program (OPSys\_b\*.cab).

The transfer is made using the following steps:

#### By Serial Port

1. Connect the cable between the PC and operator panel.
2. Open a project or create a new project with the desired operator panel type.
3. Select **Transfer/Update Operator Terminal System Program**.

No settings are required in the operator panel.

#### Over Ethernet

1. Connect the cable between the PC and operator panel.
2. Set the operator panel to **Service menu mode** (see the *Mode Switches* section).
3. Enter a valid IP address for the operator panel.
4. Set the operator panel back to **Run-mode** (see the *Mode Switches* section).
5. Open a project or create a new project with the desired operator panel type.
6. Select **Transfer/Update Operator Terminal System Program**.
7. Select **Settings/Use TCP/IP transfer**.

### Via External Memory Card

Transferring the system program to the operator panel via an external memory card requires the following:

- File with new system program (OPSys\_b\*.cab).
- Compact Flash memory card (only in EXTER K70, EXTER K100, EXTER T70, EXTER T100 and EXTER T150) or USB Flash drive.

The transfer is made using the following steps:

1. Save the system program file (OPSys\_b\*.cab) in the root of the external Compact Flash memory card or USB Flash drive.
2. Place the memory card in the operator panel, or connect the USB Flash drive, and start the operator panel to update the system program automatically.

---

#### Note:

When updating an operator panel it is important to ensure that the power is not interrupted during the transfer.

---

## Downloading the System Program in EXTER K10m and EXTER K20m

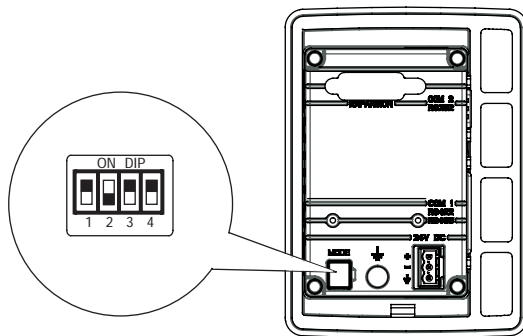
An Image Loader is used to download system programs to the operator panel via a PC. The Image Loader is available from the website. The transfer is made via the serial port using a CAB30 cable.

Updating of the system program to the operator panel requires the following:

- PC with Image Loader application.
- CAB30 cable.

Transfers are made in the following steps:

1. Run the Image Loader exe-file by double-clicking on it. Follow the instructions; also described in the following steps:
2. Connect the cable between the PC and the operator panel.
3. Disconnect the power to the operator panel.
4. Set the panel in Image Load mode by setting mode switch number 2 in the ON position according to the illustration below.



5. Reconnect power.
6. All operator panels connected to the COM-ports on the PC and currently set in Image Load mode will be available for selection from a drop down list. Select which operator panel to upgrade by selecting its MAC address (hex).
7. Click **Upgrade**.
8. When the upgrade is finished, disconnect power from the operator panel.
9. Change mode switch number 2 back in OFF position.
10. Reconnect power to the operator panel.

## 5 Environmental Aspects

This chapter includes information about the environmental impact of EXTER operator panels.

More information can be found on the manufacturer's web site.

### 5.1 General Environmental Aspects

The manufacturer's activities meet internal requirements as well as those of the SS-EN ISO 9001:2000 and SS-EN ISO 14001:2004 international standards.

### 5.2 Environmental Impact of the Operator Panels

#### 5.2.1 Mechanical Components

The aluminum and stainless steel used in the mechanical components are judged to be non-environmentally hazardous. The expanded rubber packing for the front and the expanded polyethylene packing for the display contain an adhesive that is not classified as environmentally hazardous.

Screws may have undergone the following surface treatments: Bright nickel-plating or bright zinc-plating. The membrane keyboard is made of polyester with silver wiring. On some models the keyboard contains LEDs.

Display frames and CF covers are made of halogen-free plastic, PC/ABS.

#### 5.2.2 Electronics

##### Circuit board

---

**Note:**

All operator panels are RoHS compliant.

---

The electronics are complex and almost all elements of the periodic table are represented.

##### Display

There is a separate circuit board for the display. The liquid crystals in the display are cyclohexane compounds. The fluorescent tube contains mercury and lead solder.

##### Batteries

The operator panel contains a button cell lithium battery.

The battery is not classified as environmentally hazardous by the Swedish Battery Ordinance (1997:645).

## 5.3 Recycling

The operator panels consist largely of aluminum. It is a great advantage in terms of both resources and the environment if it can be recycled. Make sure that operator panels taken out of service are sent to facilities for electronic scrap.

The manufacturer's electronic waste is recycled by Stena Technoworld AB. Aluminum front/rear casings and other covers can be removed and recycled. Plastic display frames and CF covers must be recycled as hard plastic. The circuit board contains many valuable metals and should therefore be recycled.

Remove the lithium battery. Electrolytic capacitors and displays are currently not classified as hazardous waste, but may be harmful to health and the environment.

The electrolytic capacitors should be handled as per Handbook 2001:7 (NFS) and displays as per NFS 2001:8.

The fluorescent tube must be handled as hazardous waste.

The packaging is made from wood fiber and should be recycled. The large printed label on the front, however, must first be removed as it is made of PVC vinyl. The label and the plastic bag for the brackets are recycled as soft plastic.

The manufacturer is a member of the REPA register. The protective film on the front is recycled as soft plastic. When the operator panel is no longer useful it can be returned to the manufacturer for environmentally responsible recycling. Contact the company for further information.

## 5.4 Environmental Impact Report

An operator panel impacts the environment through its function, i.e., controlling industrial equipment. The energy and the scrapped parts that can be saved with efficient management mean that the operator panel contributes to reduced environmental impact.

Listed below are examples of how you can reduce environmental impact during operator panel use.

- Switch the system off when not in use.
- Use green electricity.
- Use energy-saving options, e.g., turn off the backlight to both save energy and reduce wear on the fluorescent tube.
- If possible, reduce the backlight brightness to reduce energy consumption and increase fluorescent tube service life.

Supply the operator panel with 24 V DC. If the input voltage is lower, the loss effect increases. Ensure that the operator panel, battery, and packaging are recycled in an environmentally responsible manner.



# Index

## A

Ambient temperature 54

## B

Backlight 42

Battery 40, 63

Bus Termination RS485 57

## C

Cable 53, 61

Cable Termination RS485 57

Calibrate Touch Screen 37, 49

Circuit Board 63

Complete Front 38

Configuration Tool 60

Contact Form 10

## D

Detergent 10

Dismantling 10

Display 26, 28, 63

Display Cable 26, 28

## E

Electronics 63

EMC Protection 53

Environmental Impact 63

*Electronics 63*

*Mechanical Components 63*

Erase Project Memory 49

Ethernet 52

External Memory Card 61

## F

Fault Tracing 58

Front 38

Functionality Specification 20

## G

Galvanic Isolation 56

Glue Gun 41

Grounding 51

GSM Modem 49

## H

Hardware 11

*Self Test 50*

Hardware Replacement 22, 24

*Backlight 42*

*Battery 40*

*Complete Front 38*

*Mode Switch 24*

Hardware Self Test 50

Hardware Specification 12

Hardware Tests 11

## I

Installation Tips 51

## L

Load Project

*from Memory Card 49*

## M

Maintenance 10

Mechanics 63

*Environmental Impacts 63*

Melting Glue 41

Memory Card 61

Mode Switch 24

## N

Noise 51

## R

Recycling 64

Remote Access Viewer 60

Repairs 10

Replace Display/Display Cable 28

RoHS Compatible 63

Run Mode 49

## S

Safety 55

Scrapping 10

Self Test 50

Service 10

Service Menu 49

Software 59

*Update 60*

Software Products 59

*Information Designer 60*

*Remote Access Viewer 60*

*System Program 61*

Spare Parts 45

Support 10

System Program 61

## T

Temperature 51

Touch Screen

*Calibrate 37*

Transfer Mode 49

## U

Update Software 60

Update System Program 61

*by Serial Port 61*

*over Ethernet 61*

*via Memory Card 49, 61*

*via PC 61*

# Beijer

ELECTRONICS

---

## HEAD OFFICE

### SWEDEN

Beijer Electronics Products AB  
Box 426  
SE-201 24 Malmö, Sweden  
Tel: +46 40 35 86 00  
Fax: +46 40 93 23 01  
info@beijerelectronics.com

## SUBSIDIARIES

### GERMANY

Elektronik-Systeme Lauer GmbH & Co. KG  
Kelterstraße 59  
72669 Unterensingen, GERMANY  
Tel: +49 7022 9660 0  
Fax: +49 7022 9660 103  
info@lauer-hmi.com

### TAIWAN

Hitech Electronics Corp.  
7 & 8 F, No. 108 Min-Quan Road  
Shin-Tien, Taipei Shien, TAIWAN, R.O.C. 231  
Tel: +886-2-2218-3600  
Fax: +886-2-2218-9547  
info.hmi@hitech-lcd.com.tw

### USA

Beijer Electronics Inc.  
939 N. Plum Grove Road, Suite F  
Schaumburg, IL 601 73, USA  
Tel: +1 847 619 6068  
Fax: +1 847 619 6674  
info.usa@beijerelectronics.com

### CHINA

Beijer Electronics Co. Ltd  
Room 201, Building B, No. 1618,  
Yishan Road, Shanghai 201103, CHINA  
Tel: +86 21 6145 0400  
Fax: +86 21 6145 0499  
info@beijerelectronics.cn